



**ALTERNATIVE
FUEL VEHICLES**
SAFETY TRAINING PROGRAM



Emergency Field Guide

Hybrid, Electric, Fuel Cell, and Gaseous Fuel Vehicles

2018



NFPA'S ALTERNATIVE FUEL VEHICLES SAFETY TRAINING PROGRAM

EMERGENCY FIELD GUIDE 2018 EDITION



National Fire Protection Association
Quincy, Massachusetts

Copyright © 2018

National Fire Protection Association

DISCLAIMER

This Emergency Field Guide is not meant to replace original manufacturer Emergency Response Guides; rather, it is intended as an easy-to-use supplement to them. In the event of a discrepancy between the two, the manufacturer's Emergency Response Guide always takes precedence.

This Emergency Field Guide was developed by the NFPA using current fire-rescue service best practices and incorporating instructions and guidance from auto and battery manufacturers. The NFPA cannot guarantee the accuracy of the material herein, as much of it has been developed from other sources, some of which are proprietary. Information that is accurate at the time received may have become outdated or obsolete due to evolution of technology or design. Furthermore, rescue operations are inherently dangerous and unpredictable activities which require on-scene assessment based on overall knowledge and experience. THE NFPA THEREFORE DISCLAIMS LIABILITY FOR ANY PERSONAL INJURY, PROPERTY, OR OTHER DAMAGES OF ANY NATURE WHATSOEVER, WHETHER SPECIAL, INDIRECT, CONSEQUENTIAL, OR COMPENSATORY, DIRECTLY OR INDIRECTLY RESULTING FROM THE PUBLICATION, USE OF, OR RELIANCE ON THIS DOCUMENT. THE NFPA ALSO MAKES NO GUARANTEE OR WARRANTY AS TO THE ACCURACY OR COMPLETENESS OF ANY INFORMATION PUBLISHED IN THIS DOCUMENT.

In issuing and making this document available, the NFPA is not undertaking to render professional or other services for or on behalf of any person or entity. Nor is the NFPA undertaking to perform any duty owed by any person or entity to someone else. Anyone using this document should rely on his or her own independent judgment or, as appropriate, seek the advice of a competent professional with actual knowledge of a specific situation in determining the exercise of reasonable care in any given circumstances.

ISBN: 978-1455912742

Library of Congress Control Number: 2012939017



ALTERNATIVE FUEL VEHICLES

SAFETY TRAINING PROGRAM

PREFACE

The NFPA's Alternative Fuel Vehicles Safety Training Program Emergency Field Guide 2018 Edition is intended as a convenient, consolidated quick reference field manual for first responders to use on scene or as a study guide to provide essential information on incident response when dealing with alternatively fueled vehicles including electric, hybrid, hydrogen fuel-cell, and gaseous fuel (CNG, LNG, & propane) vehicles. The EFG provides an intuitive, easy-to-use, quick reference guide, covering all current makes and models of alternatively fueled vehicles. It contains vehicle-specific information drawn from manufacturer Emergency Response Guides, as well as generic guidance on initial response procedures and situations such as vehicle fire, submersion, and spills.

For additional AFV safety information, training, videos, tools, and quick reference materials, please visit us at:

www.AFVtechsafety.org

CONTENTS

DISCLAIMER	2
PREFACE.....	3
HOW TO USE THIS GUIDE.....	8
Alternative Fuel Vehicle Type Identifiers	8
Warning Icons and Identifiers	8
General Response	9
Vehicle-Specific Entries.....	9
GENERAL PROCEDURE	11
Initial Response.....	11
Identify Vehicle	11
Immobilize	11
Disable	12
Primary Shutdown Method	12
Secondary Shutdown Method	12
Crash / Extrication.....	13
Crashes	13
General.....	13
Extrication.....	13
General.....	13
Stabilization	14
Ultra-High-Strength Steels.....	14
Hybrid and Electric Vehicles.....	15
Damaged High Voltage Batteries	15
Manual Service Disconnects	15
Hydrogen Fuel Cell Vehicles	16
General.....	16
Hydrogen Gas Properties	16
Hydrogen Cylinders on Vehicles	17
Gaseous Fuel Vehicles.....	17
General.....	17
Natural Gas Properties	18
Propane Properties.....	18
Cylinder/Tank Locations	19
Post-Incident Handling	20

Fire	21
General.....	21
Personal Protective Equipment	21
Hybrid and Electric Vehicles.....	21
General.....	21
Extinguishing Agents	21
Tactics.....	23
Offensive Attack	23
Defensive Attack	23
Fires Involving Charging Stations.....	23
Overhaul and Recovery.....	23
Hydrogen Fuel Cell Vehicles	24
General.....	24
Gaseous Fuel Vehicles.....	24
General.....	24
CNG Vehicles	25
LNG Vehicles.....	25
LPG Vehicles.....	26
Overhaul and Recovery.....	26
Submersion	27
General.....	27
Response Practices	27
Microbubbling.....	27
Manufacturer-Specific Recommendations	28
Ford / Mercury	28
Mitsubishi.....	28
Spill/Leak Hazards	29
General.....	29
High Voltage Battery Electrolyte Leaks	30
Hydrogen Fuel Cell Vehicles	31
General.....	31
Gaseous Fuel Vehicles.....	31
CNG Vehicles	31
LNG Vehicles.....	31
LPG Vehicles	32

First Aid	33
General.....	33
Hybrid and Electric Vehicles.....	33
General.....	33
Responding to Battery Electrolyte Exposures.....	33
Contact With Skin.....	34
Contact With Eyes.....	34
If Swallowed.....	34
Inhalation of Electrolytic Vapor.....	34
Inhalation In Firefighting Situations.....	35
Hydrogen Fuel Cell Vehicles.....	35
General.....	35
Gaseous Fuel Vehicles.....	35
Natural Gas.....	35
General.....	35
Hazards.....	35
Signs and Symptoms.....	35
Treatment.....	36
Propane.....	36
General.....	36
Hazards.....	36
Signs and Symptoms.....	36
Treatment.....	36
VEHICLE TABLE OF CONTENTS	37
VEHICLE SPECIFIC GUIDE	67
ACKNOWLEDGEMENTS	455



HOW TO USE THIS GUIDE

ALTERNATIVE FUEL VEHICLE TYPE IDENTIFIERS

HYBRID-ELECTRIC VEHICLE



A hybrid electric vehicle (HEV) utilizes two power sources: a conventional internal combustion engine (ICE) and an electric motor/battery combination.

PLUG-IN HYBRID ELECTRIC VEHICLE



A plug-in hybrid electric vehicle can recharge its batteries to full charge by using a connection to an external electric power source such as a normal electric wall socket. A PHEV shares characteristics of both a hybrid electric vehicle — an electric motor and an internal combustion engine — and an all-electric vehicle — the ability to connect it to a charging station.

ELECTRIC VEHICLE



An electric vehicle (EV) uses only an electric motor(s) for propulsion and must connect to a charging station in order to recharge.

FUEL CELL VEHICLE



A fuel cell vehicle is simply another type of hybrid where the fuel cell replaces the internal combustion engine. A fuel cell generates electricity through a chemical reaction between oxygen and hydrogen. Since no combustion takes place during this process, the only byproducts are heat and water vapor. The electricity is used to power the drive motors and charge the high-voltage battery.

GASEOUS FUEL VEHICLES



A gaseous fuel vehicle can run on a number of different gas alternatives including CNG (Compressed Natural Gas), LNG (Liquefied Natural Gas), and LPG (Liquefied Propane Gas).

BI-FUEL VEHICLES



A Bi-fuel vehicle can run on traditional gasoline/diesel or on a gaseous fuel.

WARNING ICONS AND IDENTIFIERS

Lithium-ion Battery

Compressed Natural Gas

Liquefied Natural Gas

Liquefied Propane Gas

Hydrogen Fuel Cell

Warning Icon

Warning Icon



GENERAL RESPONSE SECTION

The first part of this guide consists of “General Response” sections. These sections provide initial response guidance, as well as guidance for scenarios that are not specific to any particular vehicle (Fire, Submersion, Spills, etc.).

Keep in mind that these sections are *generic* and are generally applicable to most vehicles, but there is always the possibility of contradiction between generic guidance and vehicle-specific instructions provided by the manufacturer. In any such case, always defer to vehicle-specific instructions.

SUBMERSION

GENERAL PROCEDURES FOR HYBRID AND ELECTRIC VEHICLE WATER SUBMERSION

GENERAL

- Hybrid and electric vehicles are designed to be safe in water, even when fully submerged.
- The high voltage system is isolated from the chassis and is designed to pose no shock hazard from touching the vehicle body.
- The system is designed not to energize surrounding water.
- The system is equipped with short-circuit fault detectors designed to shut down the HV system in the event of a short.

RESPONSE PRACTICES

- Avoid contact with high voltage components, cabling, or service disconnects on a submerged vehicle.
- Follow standard departmental practices and procedures for patient access and vehicle removal from water.
- It may be necessary to wait until the vehicle is safely on land and drained of water to perform or complete disabling procedures.

Submersion

MICROBUBBLING

- Microbubbling is a fizzing or bubbling reaction coming from a submerged high voltage battery.
- DOES NOT** indicate a shock hazard. This process is internal to the battery case and **DOES NOT** energize the surrounding water.
- Microbubbling is the result of electrolysis, where current passes between the positive and negative terminals within the battery and breaks the water molecules into hydrogen and oxygen gases.

WARNINGS

- This process produces flammable hydrogen gas and oxygen, which can be potentially explosive in confined spaces. Venting the passenger compartment may be necessary to reduce gas buildup.
- Never remove a submerged service disconnect!

17

General Response Pages

VEHICLE-SPECIFIC ENTRIES

This section is organized alphabetically by manufacturer and then by vehicle model for each manufacturer label.

Each vehicle entry is presented in a two-page format with critical information to help with identification, immobilization, disabling, and extrication. See the following page for layout description.

All of the primary disabling procedures, as well as the majority of alternate procedures, are designed to disable both the fuel or high voltage electrical system and the SRS (airbags, etc.). Performing any of the procedures only partially will not assure that both systems are shut down.

NISSAN LEAF

2011-12 **Zero Emission**

VEHICLE INFORMATION

IMMOBILIZE VEHICLE

1. Chock the wheels.
2. Set parking brake. (pull up on push/park switch, center console)
3. Place vehicle into park. (push P-R joystick, center console)

DISABLE VEHICLE

Determine if the vehicle is ON by presence of READY indicator: (located in lower meter assembly)

PRIMARY PROCEDURE

1. If ON, turn off vehicle by pressing power button.
2. Verify READY indicator is OFF.
3. If possible, keep proximity key at least 16 feet (5 meters) away from vehicle.
4. Disconnect negative 12V battery cable (under hood).

ALTERNATE PROCEDURE 1

1. Open under-hood fuse box (may be difficult to access).
2. Remove fuses F3, F15, F21. If correct fuse cannot be identified, pull all fuses in fuse box.
3. Disconnect negative 12V battery cable (under hood).

ALTERNATE PROCEDURE 2

1. Locate and lift the carpet flap behind the center console.
2. Remove access cover bolts and cover (10 mm hex bolts).
3. Remove the service plug by pressing the locking tab (1) and rotating the handle (2) upward. Using the handle, pull service plug completely out of socket.
4. Disconnect negative 12V battery cable (under hood).

Disconnect Cover

Remove Service Plug 1

Remove Service Plug 2

WARNINGS (continued on the next page)

- NEVER** cut, breach, or touch orange high voltage components or cabling. Doing so could result in serious injury or death.
- The high voltage system may remain powered for up to 10 minutes after the vehicle is disabled. The HV system will be below 60V after 5 minutes.
- SRS may remain powered for up to 3 minutes after vehicle is disabled.

109

Vehicle-Specific Pages

NOTE: Where possible, the locations of such components as ignition, 12V battery, parking brake, and gear selector are indicated. However, it is always possible that these components may be in other locations due to manufacturer model updates or aftermarket modifications.

HOW TO USE THIS GUIDE



HOW TO USE THIS GUIDE

Immobilization

How to Determine if Vehicle is ON/OFF

Primary Disabling Procedure

Alternate Disabling Procedures

Disabling Procedure Supporting Diagrams

Warnings

Vehicle Photo

Vehicle Type

Manufacturer Badge

Model Year Range

Vehicle Badging

Lithium-ion Battery Indicator

Make and Model Tab

System Diagrams (High Voltage, Airbags, SRS—if Available)

EV
2011-12

Zero Emission

Li-ion

VEHICLE INFORMATION

IMMOBILIZE VEHICLE

1. Chock the wheels.
2. Set parking brake. (pull up on push/pull switch, center console)
3. Place vehicle into park. (push P in joystick, center console)

DISABLE VEHICLE

Determine if the vehicle is ON by presence of READY indicator: (located on the lower dash display)

PRIMARY PROCEDURE

1. If ON, turn off vehicle by pressing power button.
2. Verify READY indicator is OFF.
3. If possible, keep proximity key at least 16 feet (5 meters) away from vehicle.
4. Disconnect negative 12V battery cable (under hood).

ALTERNATE PROCEDURE 1

1. Open under-hood fuse box (may be difficult to access).
2. Remove fuses F3, F15, F21. If correct fuse cannot be identified, pull all fuses in fuse box.
3. Disconnect negative 12V battery cable (under hood).

ALTERNATE PROCEDURE 2

1. Locate and lift the carpet flap behind the passenger seat.
2. Remove access cover bolts and nuts (10 mm hex bolts).
3. Remove the service plug by pressing the locking tab (1) and rotating the handle (2) upward. Using the handle, pull service plug completely out of socket.
4. Disconnect negative 12V battery cable (under hood).

WARNINGS (continued on the next page)

- NEVER cut, breach, or touch orange high voltage components or cabling. Doing so could result in serious injury or death.
- The high voltage system may remain powered for up to 10 minutes after the vehicle is disabled. The HV system will be below 60V after 5 minutes.
- SRS may remain powered for up to 3 minutes after vehicle is disabled.

245

EV
2011-12

Zero Emission

Li-ion

EXTRICATION INFORMATION

WARNINGS (continued)

- Removal of service plug requires the use of electrical PPE (insulated gloves, shoes, and face shields).
- In the event of a fire involving a charging station, reference the FIRE portion of this guide, and treat it as an energized electrical fire until power to the charger can be shut down.
- This vehicle does not have an internal combustion engine. Lack of engine noise does not mean vehicle is OFF. Silent movement capability exists until vehicle is fully shut down.

LEGEND			
	Airbag		Bodywork Reinforcements
	Stored Gas Inflator		Support Cylinder for Hood
	Seatbelt Tensioner or Pretensioner		High-Voltage Power Cable
	High-Voltage Battery		Emergency Disconnect (Remove Fuse)
	SRS Control Unit		Emergency Disconnect (Remove Plug)
	12V Battery		

STORAGE

The service disconnect should be removed prior to vehicle storage.

For towing and post-incident instructions, see the **POST-INCIDENT** section on page 15.

246



GENERIC INITIAL RESPONSE PROCEDURES FOR ALTERNATIVE FUEL VEHICLES

SIZE-UP / SCENE 360

IDENTIFY ⇨ IMMOBILIZE ⇨ DISABLE

IDENTIFY VEHICLE

ALWAYS ASSUME THE VEHICLE IS SOME TYPE OF HYBRID, ELECTRIC OR ALTERNATIVELY FUELED VEHICLE UNTIL PROVEN OTHERWISE.

- Look for external badging indicating an alternative fuel vehicle.
- Badging may be hidden in a crash or fire, so alternative identification methods may need to be used.
- Determine the vehicle's make, model, and year to access more specific vehicle information found in this guide.
- Some hybrid and electric models may not have external badging to identify them, but they will still have high voltage warning labels and other secondary indicators such as the "Zero Emissions" badge on a Leaf.

IMMOBILIZE

**ALL VEHICLES SHOULD BE IMMOBILIZED
PRIOR TO WORKING AROUND THEM.**

**HYBRID AND ELECTRIC VEHICLES MAY APPEAR
TO BE SHUT DOWN EVEN WHEN THEY ARE NOT,
DUE TO THE POTENTIAL LACK OF ENGINE NOISE.**

Approach the vehicle from a 45° angle to stay out of the potential path of travel, and:



1. Chock the Wheels



2. Set Parking Brake



3. Place Vehicle in Park



DISABLE

PRIMARY SHUTDOWN METHOD (for most vehicles)

1. Turn off the vehicle's ignition (if on).
2. Disconnect the 12V battery (according to vehicle instructions).

SOME VEHICLES USE A PROXIMITY KEY.

- IF THE KEY CAN BE LOCATED, REMOVE IT TO AT LEAST 16 FEET (5 METERS) FROM THE VEHICLE.
- IF IT CANNOT BE LOCATED QUICKLY, PROCEED WITH DISABLING THE VEHICLE.
- ONCE THE VEHICLE IS SHUT DOWN AND THE 12V BATTERY IS DISCONNECTED, THE PROXIMITY KEY SYSTEM IS DISABLED.

ALTERNATE SHUTDOWN METHOD (if you cannot access the ignition)

- Consult the vehicle-specific page in this guide for further information.

NOTE: Most hybrid and electric vehicles and some fuel cell and gaseous fuel vehicles are equipped with safety systems that are designed to automatically shut the vehicle down in the event of a crash. Therefore, in most crash incidents, the vehicle should already be OFF. Verify the vehicle's status, so that you do not inadvertently restart a vehicle that has already shut itself off.

NOTE: All of the primary disabling procedures, as well as the majority of alternate procedures, are designed to disable the vehicle's high voltage and/or gaseous fuel system and the SRS (airbags, etc.). Performing any of the procedures only partially will not assure that both systems are shut down.

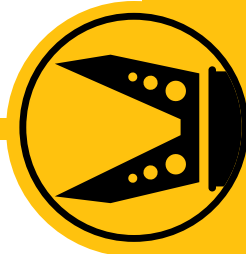

GENERAL PROCEDURES AND CONSIDERATIONS FOR ALTERNATIVE FUEL VEHICLES CRASH RESPONSE AND EXTRICATION

Always follow and reference all department SOPs when conducting vehicle crash response and extrication.

CRASHES

GENERAL

- Follow Initial Response Procedures: Perform Scene Size-Up, then Identify, Immobilize, and Disable the vehicle(s).
- If the vehicle can be identified, reference the appropriate pages in this guide or the manufacturer's response guide.
- If the vehicle cannot be identified, use the common shutdown method from the **INITIAL RESPONSE** section.



EXTRICATION

GENERAL

- Immobilize and disable the vehicle prior to starting extrication operations.
- ALWAYS stabilize the vehicle before beginning extrication (see STABILIZATION).
- Before cutting or prying, visually check to determine the location of:
 - SRS and Occupant Protection Systems.
 - HV components and cabling.
 - Gaseous fuel lines and cylinders/tanks.
- HV cabling and components are primarily routed along the underside of the vehicle from the HV battery to the underhood (engine) compartment, and therefore are NOT found in typical extrication cut points.
- Locations of HV batteries and components may prevent advanced techniques such as trunk tunneling and through-the-floor extrication.
- Gaseous fuel lines are generally routed along the underside of the vehicle from the cylinders/tanks to the engine compartment and are NOT found in typical extrication cut points.
- Cylinders/tanks can be found mounted to the inside or outside of the frame rail, on the roof, vehicle trunks, pickup truck beds or the rear cargo area of vans, depending on the fuel type and application.



CRASH/EXTRICATION

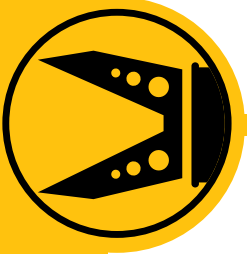

CRASH/EXTRICATION



ALWAYS stabilize the vehicle before beginning extrication.

STABILIZATION

- Use standard cribbing and stabilization methods, the same as used in conventional vehicles.
- **DO NOT** place cribbing in a location that traps or could crimp high voltage cabling or gaseous fuel lines between cribbing and vehicle frame or structural points. Visually verify before placing cribbing.

ULTRA-HIGH-STRENGTH STEELS (UHSS)

- High-strength/low-weight metals are being used heavily in newer vehicle designs.
- Hydraulic cutting tools not designed for ultra-high-strength steels may prove to be inadequate. Additionally, tools such as reciprocating saws may not be able to cut through these metals. Alternative extrication techniques may be required.
- It is highly recommended that departments review the capabilities of their cutting equipment against ultra-high-strength steels in anticipation of encountering these materials in the field.



Some cutting tools MAY NOT CUT new ultra-high-strength steels.

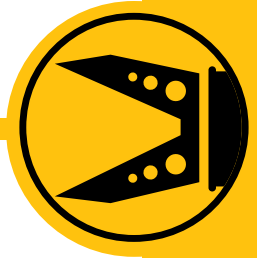

HYBRID AND ELECTRIC VEHICLES

NOTE:

In this guide, blue and yellow medium/intermediate voltage cabling is treated the same as orange high voltage (HV). All references to HV practices also apply to medium/intermediate voltage systems.

DAMAGED HIGH VOLTAGE (HV) BATTERIES

- If damaged, HV batteries may give off harmful and/or flammable fumes.
- If you detect unusual odors or experience eye, nose, throat, or skin irritation, don full PPE with SCBA.
- If you detect leaking fluids, sparks, smoke, or bubbling noises coming from the HV battery, ventilate the vehicle by opening the windows and trunk to prevent the buildup of fumes.
- Sparks, smoke, or bubbling noises coming from the HV battery are signs of a potentially overheating battery, which could result in a delayed fire.
- Contents of HV batteries should be considered corrosive, toxic, and/or flammable. See **SPILL/LEAK HAZARDS** if the battery contents are exposed or leaking.
- Avoid contact with a damaged HV battery; a significant shock hazard may exist.



Damaged High Voltage Battery

MANUAL SERVICE DISCONNECTS

- Most hybrid and electric vehicles are equipped with manual or service HV disconnects, but not all are recommended for use by emergency responders.
- Check the vehicle-specific pages or manufacturer response guides before using a manual or service disconnect.
- Many manufacturers recommend insulated electrical PPE when using service disconnects. Most departments do not own or regularly carry rated electrical PPE.
- Note that removing a service disconnect will disable the HV system, but in most vehicles, the SRS (airbags) will remain active until the 12V DC system is disabled. Removing a manual disconnect does not discharge the HV battery.



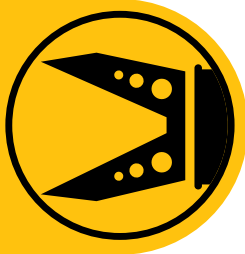

CRASH/EXTRICATION

WARNINGS

- Avoid contact with HV cabling and components. ALWAYS assume the HV system is energized.
- NEVER cut orange HV cabling or penetrate HV components with tools.
- HV system shutdown procedures are designed to disable the vehicle's HV system, not to discharge the HV battery. THE HV BATTERY WILL REMAIN ENERGIZED.
- If the vehicle's 12V system is inaccessible and cannot be disabled, the occupant protection systems, such as airbags or pretensioners, may remain active, even if the HV system is shut down.

HYDROGEN FUEL CELL VEHICLES

GENERAL

- Hydrogen fuel cell vehicles utilize the same type of HV electrical systems found in hybrid and electric vehicles.
- The traditional gasoline or diesel engine is replaced with a fuel cell powered by hydrogen gas.



HYDROGEN GAS PROPERTIES

- Colorless, odorless, and tasteless gas. It cannot be odorized like other flammable gases that responders are familiar in dealing with.
- 14 times lighter than air and rises at a rate of approximately 45 mph.
- Flammable range of 4% to 74% concentration in air.
- Auto ignition temperature of 1085 degrees Fahrenheit.



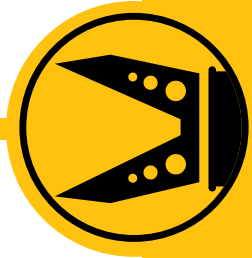

HYDROGEN CYLINDERS ON VEHICLES

- **Passenger Vehicles:** the hydrogen storage cylinders are typically found underneath the car, where the gasoline tank would normally be located.
- **Buses:** the cylinders are found on the roof.
- Cylinders are equipped with a temperature activated relief device which will activate at approximately 225 degrees Fahrenheit. On passenger vehicles, these vents are directed downward, while on buses they are vented upwards. If these vents are activated, they will empty the cylinders over the course of several minutes, depending on the capacity of the cylinder and how much gas is contained.

GASEOUS FUEL VEHICLES

GENERAL

- Compressed Natural Gas (CNG), Liquefied Natural Gas (LNG) and Liquefied Propane Gas (LPG) are the three primary gaseous fuels used to power an internal combustion engine. Hydrogen has been used on a limited basis in this application.
- Use a combustible gas meter to monitor for potential fuel leaks at a crash/extrication scene involving a gaseous fuel.
- The flow of gas from the cylinder/tank is shut down when the vehicle ignition is turned off through the use of a low voltage solenoid.
- Manual shutoffs may also be present to shut off the flow of gas.
- As with conventional vehicles, a hand line with personnel in full firefighting PPE should be in place during extrications.

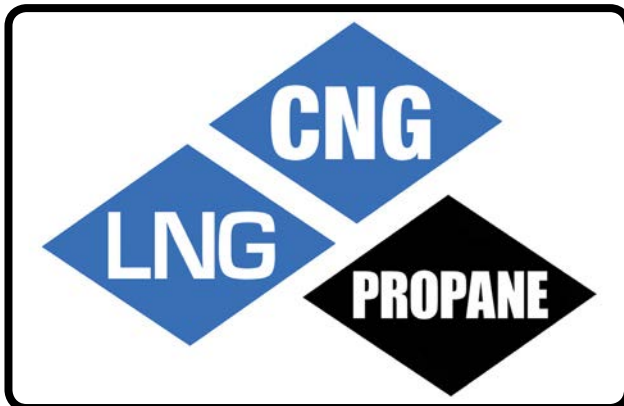



CRASH/EXTRICATION

NATURAL GAS PROPERTIES

- Natural gas is lighter than air and will rise upon its release. Its flammable range is 5 to 15 percent in air and its ignition temperature is 1,100 degrees Fahrenheit.
- Natural gas is stored on a vehicle in one of two ways, either compressed or liquefied. The storage method plays a critical factor in its behavior and how it is handled in an emergency.
- Compressed natural gas, or CNG, is stored at service pressures up to 3,600 psi. Like natural gas used in buildings, it is odorized to assist in leak detection.
- Liquefied natural gas, or LNG, has been cooled to negative 260 degrees Fahrenheit for conversion to a liquid. The typical storage pressure in the vehicle LNG tank is 120 psi, far less that of CNG.



WARNINGS

Due to its cryogenic properties, LNG cannot be odorized.

PROPANE PROPERTIES

- Propane is liquefied by pressurization at 200 psi and is stored at approximately 240 psi.
- Propane vapors are approximately 1½ times heavier than air and will settle into low lying areas when released.
- Its flammable range is approximately 2%-10% in air. The ignition temperature of propane is 1,000 degrees Fahrenheit.



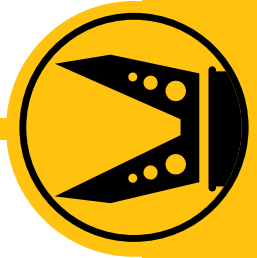

CYLINDER/TANK LOCATIONS

- **CNG Cylinders:** The mounting location of the cylinders will vary with the type of vehicle. In passenger cars they can be found in the trunk or where the gas tank would normally be located. In medium and heavy duty trucks they may be mounted underneath or directly behind the cab, arranged horizontally or vertically, or in a location similar to a diesel saddle tank. On buses and garbage trucks they can be on the roof.



- **LNG Tanks:** LNG is typically used on medium and heavy duty vehicles and the tanks are most commonly found attached to the frame rails. However, in some instances they may be located behind the cab.



- **LPG Tanks:** In passenger vehicles, the tank is located in the trunk, or where the gas tank is usually found. In vans or pickup trucks they may be underneath or in the bed. In medium or heavy duty applications they can primarily be found along the inside or outside of the frame rail. Due to the heavier than air nature of propane, tanks will not be found mounted on the roof as in some CNG vehicles.





POST-INCIDENT

- All hybrid and electric vehicles should be transported on a flatbed. If this is not possible, ensure that it is towed with drive wheels off the ground (varies by model). **TOWING WITH DRIVE WHEELS ON THE GROUND POSES A RISK OF FIRE IN THE HV ELECTRICAL SYSTEM.**
- If damage to the battery is observed or suspected, notify the dealer or manufacturer representative. They may have procedures to de-energize a battery.
- Due to the potential of delayed fire, do not store a severely damaged vehicle containing an HV Lithium Ion battery in or within 50 feet (15 meters) of a structure or other vehicle. The distance may need to be increased, depending on the size of the vehicle.
- Gaseous fuel vehicles should be inspected to make sure the fuel system is intact and not leaking prior to removal and storage.
- Post fire or crash contact the fleet service personnel or manufacturer for assistance in vehicle removal and storage.



NOTIFY TOW OPERATORS REMOVING THE VEHICLE OF THE NEED FOR TRAINED PERSONNEL TO INSPECT IT AND PROVIDE RECOMMENDATIONS FOR STORAGE OR DISPOSAL!



GENERAL PROCEDURES FOR FIRE EXTINGUISHMENT IN ALTERNATIVE FUEL VEHICLES

PERSONAL PROTECTIVE EQUIPMENT

- All personnel should wear and utilize full PPE and SCBA as required at all vehicle fires.



Use Full PPE and SCBA

HYBRID AND ELECTRIC VEHICLES

GENERAL

- Use standard vehicle firefighting equipment and tactics in accordance with department SOPs/SOGs.
- Hybrid and electric vehicles do not require special equipment for fire suppression/extinguishment.
- Difficulty in extinguishing a HV battery fire is dependent on several factors:
 - Size and location of battery.
 - Extent of fire within the battery.
 - Access and ability of extinguishing agent to be applied to the battery assembly case.
 - Potential openings in battery case that allow extinguishing agent to be placed directly on the burning cells.

EXTINGUISHING AGENTS

- Use water or other standard agents for vehicle fires.
- The use of water does not present an electrical hazard to firefighting personnel.
- If an HV battery catches fire it will require a large, sustained, volume of water. Testing has indicated it could require over 2,600 gallons, depending on the size and location of the battery. Be sure to establish a sustained water supply through a hydrant or static water source.



Safe to Use Water



WARNINGS

- If using water to extinguish/suppress a HV battery, use a large volume of water. Using only a small amount could allow dangerous toxic gases to be released.
- If a Lithium Ion (Li-Ion) HV battery is involved in a fire, there is a possibility that it could reignite after extinguishment. If available, use thermal imaging to monitor the battery. Do not store a vehicle containing a damaged or burned Li-Ion HV battery in or within 50 feet of a structure or other vehicle until the battery can be discharged.
- Re-ignition of fire in a HV battery pack is typically accompanied by “whooshing” or “popping” sounds, followed by off-gassing of white smoke and/or electrical arcs/sparks that reignited with visible flames/fire. Re-ignition can occur anywhere from several hours to day or more following extinguishment.

NOTE:

- Because HV batteries are in protective cases, it is very difficult to get any extinguishing agent directly onto the burning cells. The application of large volumes of water may cool the HV battery sufficiently to prevent the propagation of fire to adjacent cells. Continuous application of water on a localized area of the battery for a prolonged period of time before moving to another section of the battery provides for quicker extinguishment. Continue to apply water even after visible flame is no longer present to properly cool HV battery pack and prevent/reduce the risk of re-ignition.
- Anticipate longer fire suppression times once the HV battery is involved due to the difficulty in accessing the burning material inside the battery case. Testing has shown that it can take an hour or longer depending on the size and location of the battery, as well the extent of the fire.



TACTICS

WARNING

- **DO NOT** blindly pierce through the hood with tools such as a Halligan bar to gain access. This tactic could penetrate HV components in the engine compartment, creating a severe shock hazard.
- **NEVER** pierce, cut, pry or dismantle any of the vehicle's structure in an effort to get water directly into the battery. You may come into contact with a HV component, risking potential injury.

OFFENSIVE ATTACK: Recommended where exposures are present or the HV battery is *not* involved.

DEFENSIVE ATTACK: Recommended if the HV battery is involved, no exposures are present and a limited water supply is available. Due to the difficulty in reaching the burning cells inside the battery with the extinguishing agent, the Incident Commander may choose to allow it to burn itself out. Any individuals without SCBA should remain upwind of the fire and avoid inhalation, due to toxic compounds in the smoke. If there is no direct application of water it could take 90 minutes or more for the HV battery to self-extinguish.

FIRES INVOLVING CHARGING STATIONS

- Locate the power source for the charging station and shut it down.
- Until power to charging station is cut, treat the fire as you would an energized electrical fire.
- If a vehicle is plugged in to the charging station, it should be unplugged as soon as it is safe to do so. If possible, shut down the charging station first.

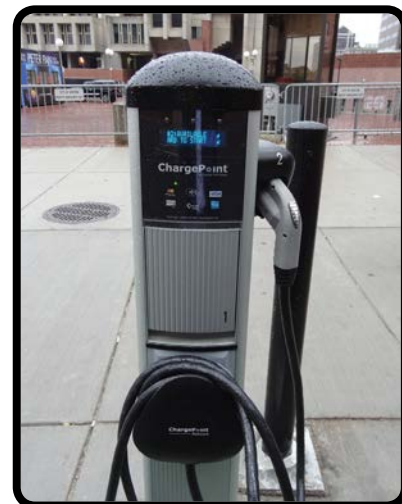

Shut Down ASAP

OVERHAUL AND RECOVERY

- Immobilize and disable the vehicle if it has not already been done.
- Never disconnect or contact any exposed HV components or wiring.
- Attempt to contact a dealer or manufacturer representative as soon as possible for help with post-incident vehicle disposition and de-energizing the HV battery if necessary.
- Never breach or remove the HV battery. Doing so may result in severe electrical burns, shock, and/or electrocution.
- Do not store a vehicle with a damaged or burned Li-Ion battery in or within 50 feet (15 meters) of a structure or another vehicle until the battery can be discharged.



HYDROGEN FUEL CELL VEHICLES

GENERAL

- High voltage electrical batteries and components are handled in the same manner as they are in a HEV or EV.
- Emergency responders should use thermal imagers when dealing with any hydrogen emergency in order to determine the presence of fire.
- Hydrogen fires should not be extinguished unless the flow of gas can be stopped.

WARNINGS

- Hydrogen fires produce almost no radiant heat and no smoke, making it almost impossible to sense the presence of a fire until you are very near or even in the flame. However, at night the flame is visible to the naked eye. Hydrogen burning with other carbon-based flames will likely give color to the hydrogen flame.
- Composite hydrogen cylinders utilize temperature pressure relief devices (TPRDs). In the event there is flame or heat impingement on a composite cylinder DO NOT attempt to cool the cylinder. This may cool the TPRD and prevent it from functioning which can result in a catastrophic cylinder failure.
- Allow the TPRDs to function as designed and vent the hydrogen.

GASEOUS FUEL VEHICLES

GENERAL

- Position the apparatus at a safe distance and approach the vehicle at a 45 degree angle in structural firefighting PPE.
- Combustible gas meters should be utilized at all scenes.
- Always treat cylinders and tanks as pressurized, even if you believe the relief devices have activated.
- Never attempt to extinguish a fire fueled by an active gas leak unless the flow of the gas can be shut down. Protect surrounding exposures until the fuel supply is exhausted.
- All cylinders and tanks involved in an accident or fire must be inspected, defueled and removed from service by trained personnel, especially when dealing with CNG cylinders.





CNG VEHICLES

- Special care must be taken with fires involving CNG vehicles. If the fire is small, and remote enough from the cylinder location that there is no potential for flame or heat impingement, then extinguish it normally. Be aware, however, that fire exposure may not always be apparent.
- In the case of more significant fire or if the cylinders are already involved, do not approach the vehicle. Establish a safe perimeter of at least 80 to 100 feet and allow it to burn while protecting any exposures.
- Any attempts to extinguish the fire, especially if water is applied to the cylinders, may prevent the temperature activated relief device from working properly and could result in catastrophic container failure.



WARNINGS

At no time should water be applied directly to composite cylinders as it can prevent the temperature pressure relief devices (TPRDs) from functioning properly.

LNG VEHICLES

- LNG vehicle fires can be extinguished using standard tactics unless fire is being fueled by an active leak. In that case protect exposures and allow it to burn.
- Typically the tanks are so well insulated that even if the vehicle becomes fully involved, there will be very little pressure increase inside the tank.
- If there is an increase, the pressure relief valve will activate and bleed off the excess pressure, resetting itself when complete. Application of water to the tanks will not prevent it from working properly.





LPG VEHICLES

- You can extinguish fires involving LPG vehicles using standard techniques.
- In the event of fire impingement on the tanks, be sure to apply copious amounts of water to keep them cool and prevent a BLEVE. This may occur if the PRD is unable to maintain a safe pressure.
- If a sufficient water supply is not available, evacuate to a safe distance and allow the fire to burn.

OVERHAUL AND RECOVERY

- Always treat cylinders and tanks as pressurized, even if you believe the relief devices have activated.
- All cylinders and tanks involved in an accident or fire must be inspected, defueled and removed from service by trained personnel, especially when dealing with CNG cylinders. Advise recovery personnel of this.



GENERAL PROCEDURES FOR HYBRID, ELECTRIC AND FUEL CELL VEHICLE WATER SUBMERSION

GENERAL

- Hybrid, electric and fuel cell vehicles are designed to be safe in water, even when fully submerged.
 - The HV system is isolated from the chassis and is designed to pose no shock hazard from touching the vehicle body.
 - The system is designed not to energize surrounding water.
 - The system is equipped with short-circuit fault detectors designed to shut down the HV system in the event of a short.

RESPONSE PRACTICES

- Avoid contact with HV components, cabling, or service disconnects on a submerged vehicle.
- Follow standard departmental practices and procedures for patient access and vehicle removal from water.
- It may be necessary to wait until the vehicle is safely on land and drained of water to perform or complete disabling procedures.



Submersion

MICROBUBBLING

- Microbubbling is a fizzing or bubbling reaction coming from a submerged HV battery.
- It DOES NOT indicate a shock hazard. This process is internal to the battery case and DOES NOT energize the surrounding water.
- Microbubbling is the result of electrolysis, where current passes between the positive and negative terminals within the battery and breaks the water molecules into hydrogen and oxygen gases.
- When microbubbling stops, the high voltage battery has been discharged.

WARNINGS

- This process produces flammable hydrogen gas and oxygen, which can be potentially explosive in confined spaces. Venting the passenger compartment may be necessary to reduce gas buildup.
- Never remove a submerged service disconnect!
- Partial submersion in water such as during a flood, can result in the shorting out of internal components and possible fire.



MANUFACTURER-SPECIFIC RECOMMENDATIONS

Some manufacturers may have model-specific guidance for submerged vehicles. Refer to the appropriate vehicle response guide found later in this document for handling and shutdown procedures.

FORD/MERCURY (Escape, Fusion, Mariner, Milan Hybrids): Ford recommends that a submerged vehicle not be removed from water until the HV battery is completely discharged (when microbubbling has completely stopped).

MITSUBISHI (Mitsubishi i): After removing the vehicle from water, flush the HV battery by the following procedure: Remove the service lid (under front driver's seat) while wearing insulating PPE (400V minimum resistance gloves), and pour at least 8 gallons (30 liters) of non-saline water into the service lid hole.



Vehicle body and surrounding water **NOT** electrified.



GENERAL PROCEDURES FOR ALTERNATIVE FUEL VEHICLE SPILL/LEAK HAZARDS

HYBRID AND ELECTRIC VEHICLES

NOTE:

High voltage (HV) batteries, whether Nickel-Metal Hydride (NiMH) or Lithium Ion (Li-Ion), are essentially considered dry cell batteries, and if damaged or breached, electrolyte leakage should be minimal.

GENERAL

- Follow departmental SOP for common automotive fluids. Hybrid and electric vehicles can contain many of the same common automotive fluids as conventional vehicles.
- Secure the area and keep non-emergency personnel out of the hazard zone.
- Wear appropriate respiratory and structural firefighting PPE when working around leaked contents from a hybrid or electric vehicle battery.
- When possible, attempt to contain the leaked electrolyte and prevent its introduction into the environment.



Fumes from ruptured Lithium Ion battery cells are often irritating or toxic. Wear SCBA and appropriate PPE.

NOTE:

Some HV batteries are liquid-cooled. If such a battery is damaged, coolant may leak. The coolant is similar to that found in conventional vehicle radiators and should not be confused with battery electrolyte (though cross-contamination with electrolyte is possible if the damage is extensive).



SPILL/LEAK HAZARDS

HIGH VOLTAGE (HV) BATTERY ELECTROLYTE LEAKS

WARNINGS

- Due to the difficulty in determining the composition of a specific HV battery, electrolyte from all HV batteries should be considered potentially corrosive, toxic, and/or flammable.
- If damaged, the HV battery may give off harmful or flammable vapors. Use full PPE and SCBA and avoid direct contact with the battery, as it may also present a shock hazard.
- If you detect unusual odors or experience eye, nose, throat, or skin irritation, don full PPE with SCBA and immediately remove occupants and response personnel from the vehicle, if possible.
- If such fumes are present, immediate removal of patients is not possible, and if equipment is available, set up positive pressure ventilation (PPV) or a smoke ejector to direct vapors away from the interior of the vehicle. If possible, provide patient(s) oxygen by a non-rebreather at a minimum, to reduce the potential for the inhalation of hazardous gases.

- Contain any leaking fluids and dispose of them in accordance with department SOP.
- Contact the local dealer or manufacturer for guidance on the handling and disposal of any leaked electrolyte.



Consider all battery electrolyte caustic or corrosive, especially Nickel-Metal Hydride (NiMH). Wear appropriate PPE.



HYDROGEN FUEL CELL VEHICLES

GENERAL

- Electrolyte leaks from the high voltage battery are handled as outlined in the previous section for HEVs and EVs.
- Hydrogen leaks - Due to its extremely low vapor density, escaping hydrogen will rise and dissipate rapidly.
- Control potential ignition sources in the area and allow the cylinder to vent.
- Combustible gas meters can indicate the presence of hydrogen, although most commonly used meters would not provide precise LEL information without a relative response chart. Responders should determine if this information is available for their assigned metering package.



GASEOUS FUEL VEHICLES

CNG VEHICLES

- Physical damage to CNG cylinders could result in containment failure and the release of a gas stored at 3,600 psi.
- Since natural gas rises, the concentration is not likely to reach its flammable range anywhere other than near the release point, unless you are in an enclosed space.
- Control potential ignition sources in the area and allow the cylinder to vent.



LNG VEHICLES

- If the tank is punctured you will see frost appear and hear the gas release. Despite being stored as a liquid there is very little chance of it leaving the tank in that state. It vaporizes so quickly it will exit as a gas at a low pressure and rise.
- Any visible vapor cloud is condensed moisture from the air. The edge of that cloud falls within its flammable range.





SPILL/LEAK HAZARDS



WARNINGS

Responders should also consider the cryogenic nature of the liquid and gas and cover any exposed skin surfaces, including the face, if there is the potential for any contact, such as in a rescue situation. Structural firefighting PPE will provide sufficient protection.

LPG VEHICLES

- Propane is a heavier than air gas which will pool in low lying areas, increasing the potential for reaching its flammable range.
- Control ignition sources, especially those low to the ground.
- Prevent the gas from flowing down into any below grade locations such as storm drains.
- The low pressure release will be accompanied by a vapor cloud.
- Vapor dispersion using hose lines can be used to control the released gas.





GENERAL PROCEDURES FOR FIRST AID FOR ALTERNATIVE FUEL VEHICLE SPECIFIC HAZARDS

NOTE:

The practices below are not intended to replace or supersede your local medical directives, protocols, or departmental SOPs.

HYBRID AND ELECTRIC VEHICLES

GENERAL

- Follow local medical protocols and First Aid SOPs for any burn, electrical, or other injuries.



RESPONDING TO BATTERY ELECTROLYTE EXPOSURES

- Exposure to HV battery electrolyte is unlikely except in a severe crash.
- Wear appropriate PPE if exposure to electrolyte is expected. SCBA is highly recommended due to the possibility of severely irritating fumes.
- PPE for handling electrolyte or a damaged battery that may be leaking includes:
 - Gloves suitable for organic solvents (rubber, latex, nitrile, etc.).
 - Apron or overgarment suitable for organic solvents (rubber, tyvek, etc.).
 - Boots suitable for organic solvents (rubber, etc.).
 - Handling a damaged HV battery is highly inadvisable. However, if handling is absolutely necessary, HV electrical PPE should be worn.



WARNINGS

- Handling a damaged HV battery should only be done when absolutely necessary, as it presents a significant potential hazard.
- NiMH battery electrolyte is a caustic alkaline (pH 13.5) that is damaging to human tissues. To avoid injury by coming into contact with electrolyte, wear proper PPE.



NOTE:

Any clothing or PPE that may have come into contact with electrolyte should be either decontaminated or discarded appropriately.

CONTACT WITH SKIN

- Remove contaminated clothing.
- Flush skin with water for 20 minutes.
- Seek immediate medical attention.



CONTACT WITH EYES

- Immediately flush with water for 15-20 minutes. Ensure adequate flushing by separating eyelids with fingers.
- Seek immediate medical attention.

IF SWALLOWED

- Allow patient to drink large quantities of water to dilute the electrolyte (never give water to an unconscious person).
- Do not induce vomiting.
- If vomiting occurs spontaneously, keep the patient's head lowered and forward to reduce the risk of asphyxiation. If unconscious keep the patient's head to the side and have suction ready.
- Seek immediate medical attention.
- Contact the Poison Control Center at 1-800-222-1222.



INHALATION OF ELECTROLYTIC VAPOR

- If electrolyte leaks and gets exposed to the air, electrolytic vapors may be released. Even in a non-fire situation, the electrolytic vapors may be toxic or at least severely irritating.
- If vapors are inhaled, immediately move to fresh air.
- If inhalation exposure is expected, administer oxygen and transport the patient to an appropriate medical facility.



INHALATION IN FIREFIGHTING SITUATIONS

- Toxic gases are given off as by-products of combustion. All responders should wear the proper PPE for fire fighting, including SCBA.
- In the event of smoke inhalation, administer oxygen and transport the patient to an appropriate medical facility.

HYDROGEN FUEL CELL VEHICLES

GENERAL

- Procedures outlined in the HEV/EV section of this guide are applicable for those components found in fuel cell vehicles as well.
- The health hazard associated with exposure to hydrogen is limited to potential asphyxiation in the event that it is released in a closed space. Hydrogen is a buoyant gas and will rise quickly, making its collection in specific area less likely to occur.

GASEOUS FUEL VEHICLES

NATURAL GAS

GENERAL

- Most significant route of entry is by inhalation in its gaseous form.
- Non-toxic.

HAZARDS

- Considered a simple asphyxiate. High concentrations of gas can cause an oxygen-deficient environment.
- Additionally, LNG presents a cryogenic hazard.

SIGNS AND SYMPTOMS

- Shortness of breath, drowsiness, headaches, confusion, decreased coordination, visual disturbances and vomiting, and are reversible if exposure is stopped.
- Continued exposure can lead to hypoxia (inadequate oxygen), cyanosis (bluish discoloration of the skin), numbness of the extremities, unconsciousness and death.





TREATMENT

- Remove victim to fresh air as quickly as possible.
- Administer oxygen per medical protocols.
- Treat burned or frostbitten skin by flushing or immersing the affected area(s) in lukewarm water.
- Do not rub affected area.
- Do not remove clothing that adheres due to freezing.
- After sensation has returned to the frostbitten skin, keep skin warm, dry, and clean. If blistering occurs, apply a sterile dressing. Seek immediate medical attention.

PROPANE

GENERAL

- Most significant route of entry is by inhalation.

HAZARDS

- Considered a simple asphyxiate. High concentrations of heavier than air gas can cause an oxygen-deficient environment, especially in low lying areas.
- Contact with the liquefied gas or rapidly expanding gases may cause frostbite.



SIGNS AND SYMPTOMS

- Individuals breathing such an atmosphere may experience symptoms which include headaches, ringing in ears, dizziness, drowsiness, unconsciousness, nausea, vomiting, and depression of all the senses. The skin of a victim may have a blue color.
- On contact with the liquefied gas or rapidly expanding gases, skin color may change to white or grayish-yellow.

TREATMENT

- Remove victim to fresh air as quickly as possible.
- Administer oxygen per medical protocols.
- In case of frostbite, place the frostbitten part in warm water. **DO NOT USE HOT WATER.**
- If warm water is not available, or is impractical to use, wrap the affected parts gently in blankets. Or, if the fingers or hands are frostbitten, place the affected area in the armpit.
- Encourage victim to gently exercise the affected part while being warmed.

ACURA..... 67

ILX

MDX

2013-14

Page 67

2017-18

Page 69

NSX

RLX

2017-18

Page 71

2014,16-18

Page 73

AUDI..... 75

A3 SPORTBACK E-TRON

Q5

2016-18

Page 75

2013-16

Page 77

AZURE DYNAMICS 79

BALANCE

TRANSIT CONNECT

2008-11

Page 79

2010-12

Page 81

BMW 83

3 SERIES

7 SERIES

2016-18 Page 83

ACTIVE HYBRID 3

2016-18 Page 85

ACTIVE HYBRID 5

2013-15 Page 87

ACTIVE HYBRID 7 (1ST GEN)

2013-16 Page 89

ACTIVE HYBRID 7 (2ND GEN)

2010-12 Page 91

I3 (1ST GEN)

2013-15 Page 93

I3 (2ND GEN)

2014-15 Page 95

2015-18 Page 97

BMWCONTINUED

I8 (1ST GEN)

I8 (2ND GEN)

2014-15 Page **99**

X5

2015-18 Page **101**

X6

2015-18 Page **103**

2010-11 Page **105**

BUICK 107

LACROSSE (1ST GEN)

LACROSSE (2ND GEN)

2012-16 Page **107**

2018-19 Page **109**

REGAL

2012-16 Page **111**

CADILLAC 113

CT6

ELR

2017-18 Page **113**

2014-16 Page **115**

ESCALADE

2008-13 Page **117**

CHEVROLET 119

BOLT

EQUINOX

2017-19 Page **119**

2007-08 Page **121**

EXPRESS CNG

EXPRESS LPG

2011-19 Page **123**

2011-19 Page **125**

CHEVROLET.....CONTINUED

IMPALA CNG

MALIBU

2015-16 Page 127

2007-09 Page 129

MALIBU ECO WITH EASSIST

MALIBU

2013-15 Page 131

2016-19 Page 133

SILVERADO (1ST GEN)

SILVERADO (2ND GEN)

2004-07 Page 135

2009-13 Page 137

SILVERADO CNG

SILVERADO WITH EASSIST

2015 Page 139

2016-18 Page 141

CHEVROLET.....CONTINUED

SPARK EV

TAHOE

2014-16 Page 143

2008-14 Page 145

VOLT (1ST GEN)

VOLT (2ND GEN)

2011-15 Page 147

2016-19 Page 149

CHRYSLER 151

ASPEN

PACIFICA

2009 Page 151

2017-18 Page 153

DODGE..... 155

DURANGO

2009 Page 155

ELECTRIC VEHICLES INTERNATIONAL..... 157

M2-MD

P70E / P10XE

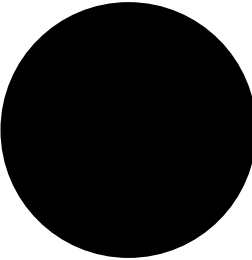

Page 157

Page 159

FERRARI..... 161

LAFERRARI

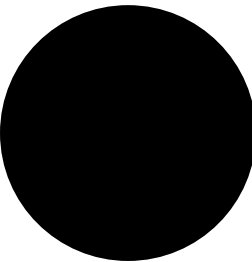

2013-16 Page 161

FIAT 163

500E

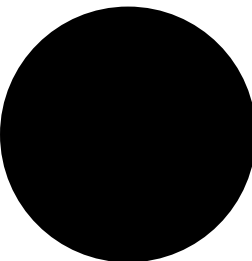

2013-18 Page 163

FISKER..... 165

KARMA

2012-13 Page 165

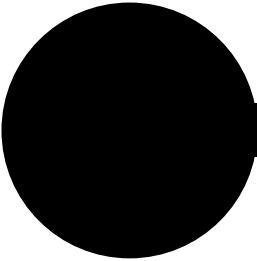

FORD..... 167

C-MAX

C-MAX ENERGI

2013-18 Page **167**

ESCAPE (1ST GEN)

2013-18 Page **169**

ESCAPE (2ND GEN)

2005-07 Page **171**

FOCUS ELECTRIC

2008-12 Page **173**

FUSION (1ST GEN)

2012-18 Page **175**

FUSION (2ND GEN)

2010-12 Page **177**

FUSION ENERGI

2013-18 Page **179**

2013-18 Page **181**

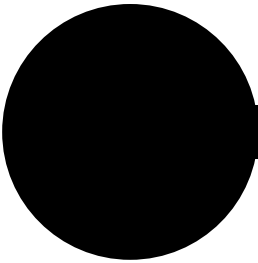

GILLIG..... 183

BUS - ALLISON

BUS - BAE

2003-18

Page 183

2003-18

Page 185

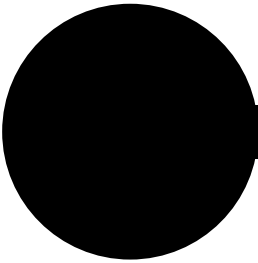

GMC 187

SAVANA CNG

SAVANA LPG

2011-19

Page 187

2011-19

Page 189

SIERRA (1ST GEN)

SIERRA (2ND GEN)

2004-07

Page 191

2009-13

Page 193

SIERRA CNG

SIERRA WITH EASSIST

2015

Page 195

2016-18

Page 197

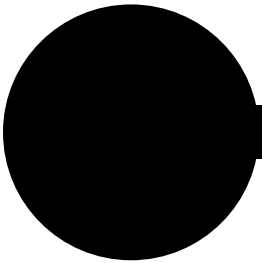

GMCCONTINUED

YUKON

2009-14

Page 199

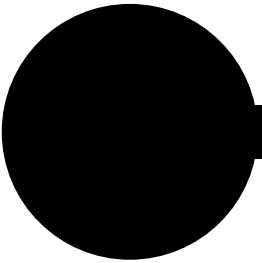

HINO 201

195H

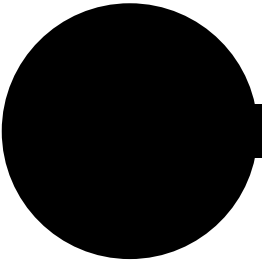

HONDA..... 203

ACCORD (1ST GEN)

ACCORD (2ND GEN)

2005-07

Page 203

2014-15,17

Page 205

ACCORD (3RD GEN)

ACCORD PLUG-IN

2018

Page 207

2014

Page 209

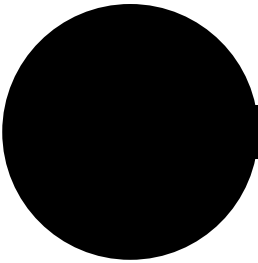

HONDA.....CONTINUED

CIVIC (1ST GEN)

CIVIC (2ND GEN)

2003-05 Page **211**

2006-11 Page **213**

CIVIC (3RD GEN)

CIVIC GX (1ST GEN)

2012-15 Page **215**

1998-2000 Page **217**

CIVIC GX (2ND GEN)

CIVIC GX (3RD GEN)

2001-05 Page **219**

2006-11 Page **221**

CIVIC GX (4TH GEN)

CLARITY EV

2012-15 Page **223**

2017-18 Page **225**

HONDA.....CONTINUED

CLARITY FC (2ND GEN)

CLARITY PHEV

2017-18

Page 227

2018

Page 229

CR-Z

FIT EV

2011-16

Page 231

2013-14

Page 233

INSIGHT (1ST GEN)

INSIGHT (2ND GEN)

2000-06

Page 235

2010-14

Page 237

HYUNDAI 239

IONIQ EV

IONIQ HEV

2017-18

Page 239

2017-18

Page 241

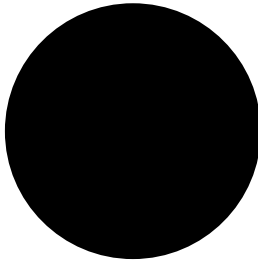

HYUNDAICONTINUED

IONIQ PHEV

SONATA (1ST GEN)

2018

Page 243

2011-15

Page 245

SONATA (2ND GEN)

SONATA PHEV

2016-18

Page 247

2016-18

Page 249

TUCSON

2013-17

Page 251

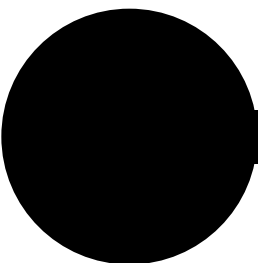

INFINITI 253

M35H

Q50

2012-13

Page 253

2014-18

Page 255

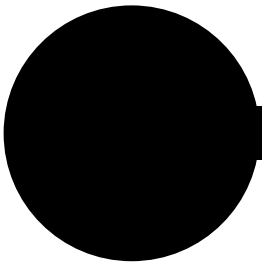

INFINITICONTINUED

Q70

QX60

2014-18

Page 257

2014-17

Page 259

KIA 261

NIRO HEV

NIRO PHEV

2017-18

Page 261

2018

Page 263

OPTIMA (1ST GEN)

OPTIMA (2ND GEN)

2011-16

Page 265

2017-18

Page 267

OPTIMA PHEV

SOUL EV

2017-18

Page 269

2015-18

Page 271

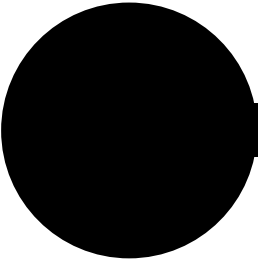

LEXUS..... 273

CT 200H (1ST GEN)

CT 200H (2ND GEN)

2011-13

Page 273

2014-17

Page 275

ES 300H

GS 450H (1ST GEN)

2013-18

Page 277

2007-11

Page 279

GS 450H (2ND GEN)

GS 450H (3RD GEN)

2013-15

Page 281

2016-18

Page 281

HS 250H

LC 500H

2010-12

Page 283

2018

Page 285

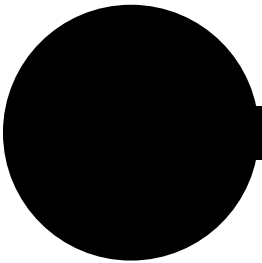

LEXUS.....CONTINUED

LS 500H

LS 600HL (1ST - 3RD GEN)

2018

Page 287

2008-16

Page 289

NX 300H

RX 400H

2015-18

Page 293

2006-08

Page 295

RX 450H (1ST GEN)

RX 450H (2ND GEN)

2010-15

Page 297

2016-18

Page 299

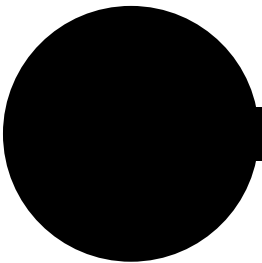

LINCOLN..... 301

MKZ (1ST GEN)

MKZ (2ND GEN)

2011-12

Page 301

2013-18

Page 303

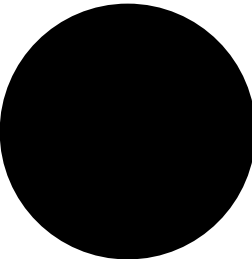

MAZDA..... 305

TRIBUTE

2008-09

Page 305

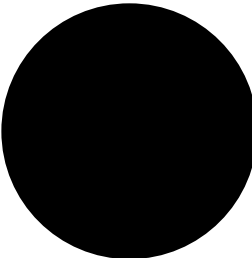

MERCEDES-BENZ 307

F-CELL

ML 450

2011-12

Page 307

2010-11

Page 309

S 400

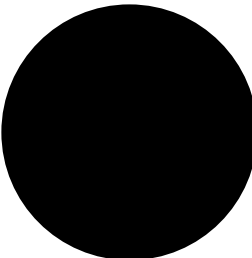

MERCURY..... 313

MARINER (1ST GEN)

MARINER (2ND GEN)

2010-13

Page 311

2006-07

Page 313

2008-11

Page 315

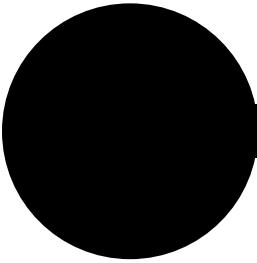

MERCURYCONTINUED

MILAN

2010-11 Page 317

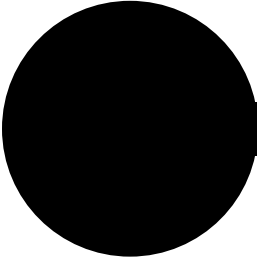

MINI 319

COOPER S E COUNTRYMAN

2017-18 Page 319

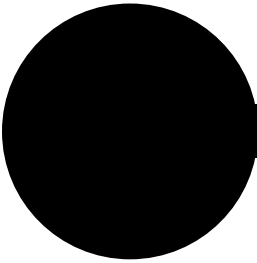

MITSUBISHI 321

i MIEV

OUTLANDER

2012-17 Page 321

2018 Page 323

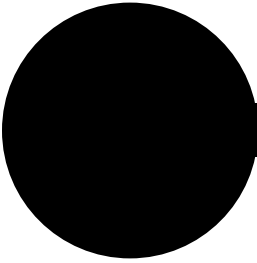

NISSAN 325

ALTIMA

LEAF (1ST GEN)

2007-11 Page 325

2011-12 Page 327

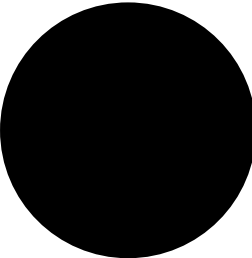

NISSANCONTINUED

LEAF (2ND GEN)

LEAF (3RD GEN)

2013-17 Page **329**

2018 Page **331**

MURANO

PATHFINDER

2016 Page **333**

2014-15 Page **335**

ROGUE

2017-18 Page **337**



NOVA BUS

NOVA BUS 339

LFS CNG

LFSe

2015-19 Page **339**

2016-19 Page **341**

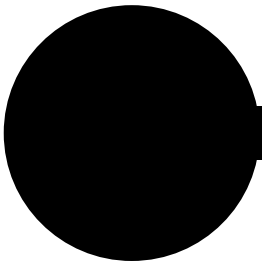

PORSCHE 343

918 SPYDER

CAYENNE S

2015 Page **343**

CAYENNE S E-HYBRID

2012-14 Page **345**

PANAMERA S

2015-18 Page **347**

2012-13 Page **349**

PANAMERA S E-HYBRID

2014-16 Page **351**

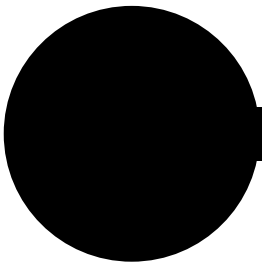

PROTERRA 353

ECORIDE BE35

2010-15 Page **353**

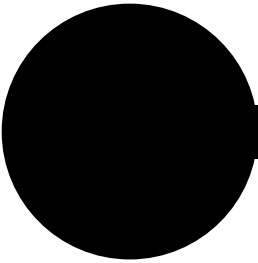

SATURN 355

AURA

VUE

2007-09

Page 355

2007-10

Page 357

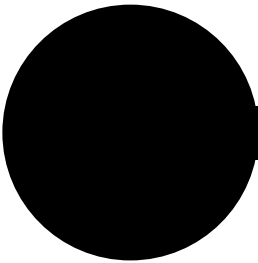

SCION 359

IQ EV

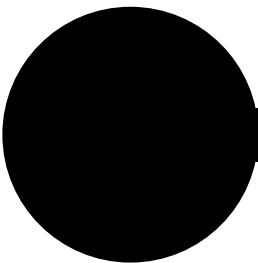

SMART 361

FORTWO ELECTRIC DRIVE

2013

Page 359

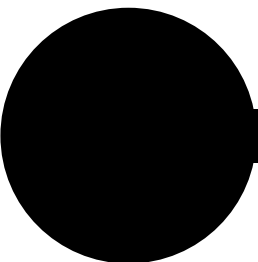

SMITH 363

SMITH NEWTON (1ST GEN)

SMITH NEWTON (2ND GEN)

2011

Page 361

2006-12

Page 363

2012-15

Page 365

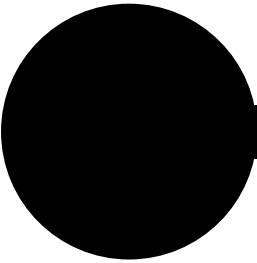

SMITH.....CONTINUED

SMITH NEWTON STEP VAN

2012-15 Page 367

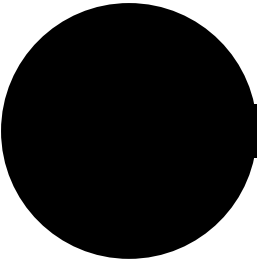

SUBARU 369

XV CROSSTREK

2014-15 Page 369

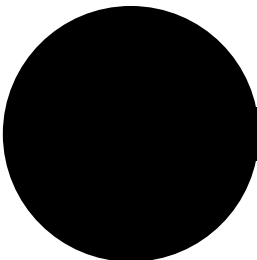

TESLA 371

MODEL 3

MODEL S (1ST GEN)

2017-18 Page 371

MODEL S (2ND GEN)

2012-15 Page 373

MODEL S (DUAL MOTOR)

2016-18 Page 375

2014-15 Page 377

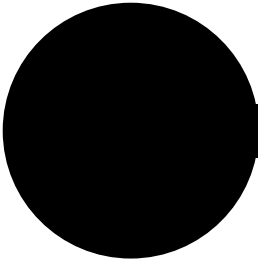

TESLACONTINUED

MODEL X

ROADSTER

2016-18

Page 379

2008-09

Page 381

ROADSTER 2

2010-13

Page 383

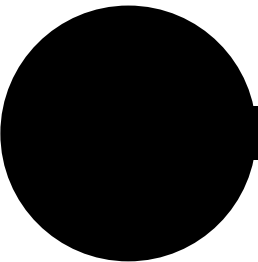

TOYOTA 385

AVALON (1ST GEN)

AVALON (2ND GEN)

2013-15

Page 385

2016-18

Page 387

AVALON (3RD GEN)

CAMRY (1ST GEN)

2019

Page 389

2007-11

Page 391

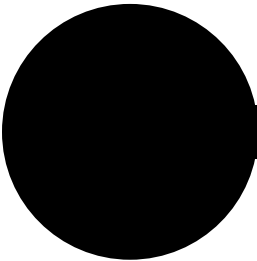

TOYOTACONTINUED

CAMRY (2ND GEN)

CAMRY (3RD GEN)

2012-14 Page **393**

2015-17 Page **393**

CAMRY (4TH GEN)

HIGHLANDER (1ST GEN)

2018 Page **395**

2006-07 Page **397**

HIGHLANDER (2ND GEN)

HIGHLANDER (2ND GEN)

2008-10 Page **399**

2011-13 Page **399**

HIGHLANDER (3RD GEN)

HIGHLANDER FCHV (1ST GEN)

2014-18 Page **401**

2005-08 Page **403**

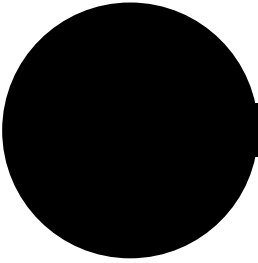

TOYOTA.....CONTINUED

HIGHLANDER FCHV (2ND GEN)

MIRAI

2009-14 Page **405**

PRIUS (1ST GEN)

2016-18 Page **407**

PRIUS (2ND GEN)

2001-03 Page **409**

PRIUS (3RD GEN)

2004-09 Page **411**

PRIUS (4TH GEN)

2010-15 Page **413**

PRIUS C (1ST GEN)

2016-18 Page **417**

PRIUS C (2ND GEN)

2012-14 Page **419**

2015-18 Page **419**

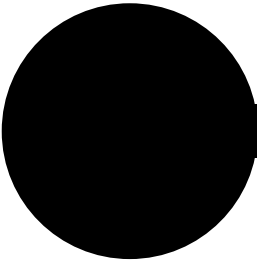

TOYOTACONTINUED

PRIUS PLUG-IN (1ST GEN)

PRIUS PLUG-IN (2ND GEN)

2010 Page **421**

2012-15 Page **423**

PRIUS PRIME

PRIUS V (1ST GEN)

2017-18 Page **425**

2012-14 Page **427**

PRIUS V (2ND GEN)

RAV 4 EV (2ND GEN)

2015-18 Page **427**

2012-14 Page **429**

RAV 4 HEV

2016-18 Page **431**

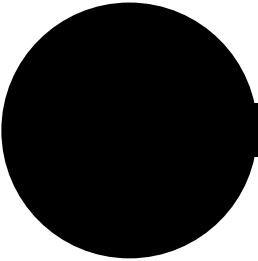

VAN HOOL 433

A300L

2010-14 Page 433

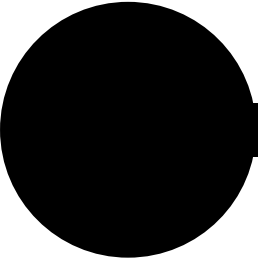

VOLKSWAGEN 435

E-GOLF

JETTA

2014-18 Page 435

2011-16 Page 437

TOUAREG

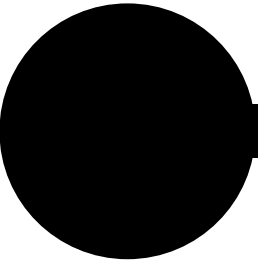

VOLVO 441

C30

S60L

2011-14 Page 439

2011-12 Page 441

2016-18 Page 443

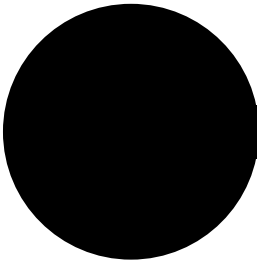

VOLVOCONTINUED

S90

V90

2017-18

Page 445

2017-18

Page 447

XC60

XC90

2018

Page 449

2016-18

Page 451

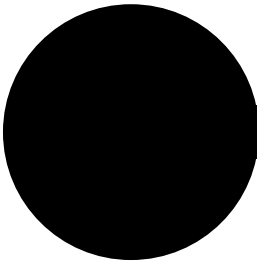

XL HYBRIDS 453

VAN CONVERSION

2010-15

Page 453

THIS PAGE INTENTIONALLY LEFT BLANK



2013-14

Hybrid



ACURA

ACURA

ILX

VEHICLE INFORMATION

Li-ion
See pages 15, 22.

IMMOBILIZE VEHICLE

- 1. **Chock the wheels.**
- 2. **Set parking brake.**
(hand brake, center console)
- 3. **Place vehicle into park.**
(gear selector, center console)

DISABLE VEHICLE

PRIMARY PROCEDURE

- 1. If ON, turn vehicle off by pressing START/STOP button for 3 seconds (right of steering column). If equipped, remove the proximity key at least 20 feet from vehicle.
- 2. Locate the 12V battery (driver side, engine compartment) and cut the negative cables.



Start Button

ALTERNATE PROCEDURE

(if the ignition button is not accessible)

- 1. Locate the 12V battery (engine compartment driver side) and cut the negative cables.
- 2. Locate the underhood fuse box, and remove the cover.
- 3. Locate the main fuse by referring to the diagram inside the fuse box cover.
- 4. Using a Phillips screwdriver, remove the main fuse screw and then remove the main fuse.



Cut the Negative Cables

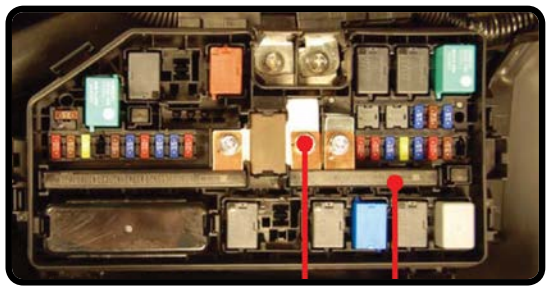

Remove the Main Fuse

NOTE: If you cannot perform either method to stop the engine and prevent current flow into the HV cables, use extreme care, do not cut into the cables, and do not touch damaged cables as they may be "hot."

WARNINGS

- NEVER cut, breach, or touch high voltage components or cabling. Doing so could result in serious injury or death.
- The SRS system (airbags, etc.) may remain powered for up to 3 minutes after disabling.
- Lack of engine noise does not mean vehicle is OFF. Silent movement or instant restart capability exists until vehicle is fully shut down.

HEV

ACURA



2013-14









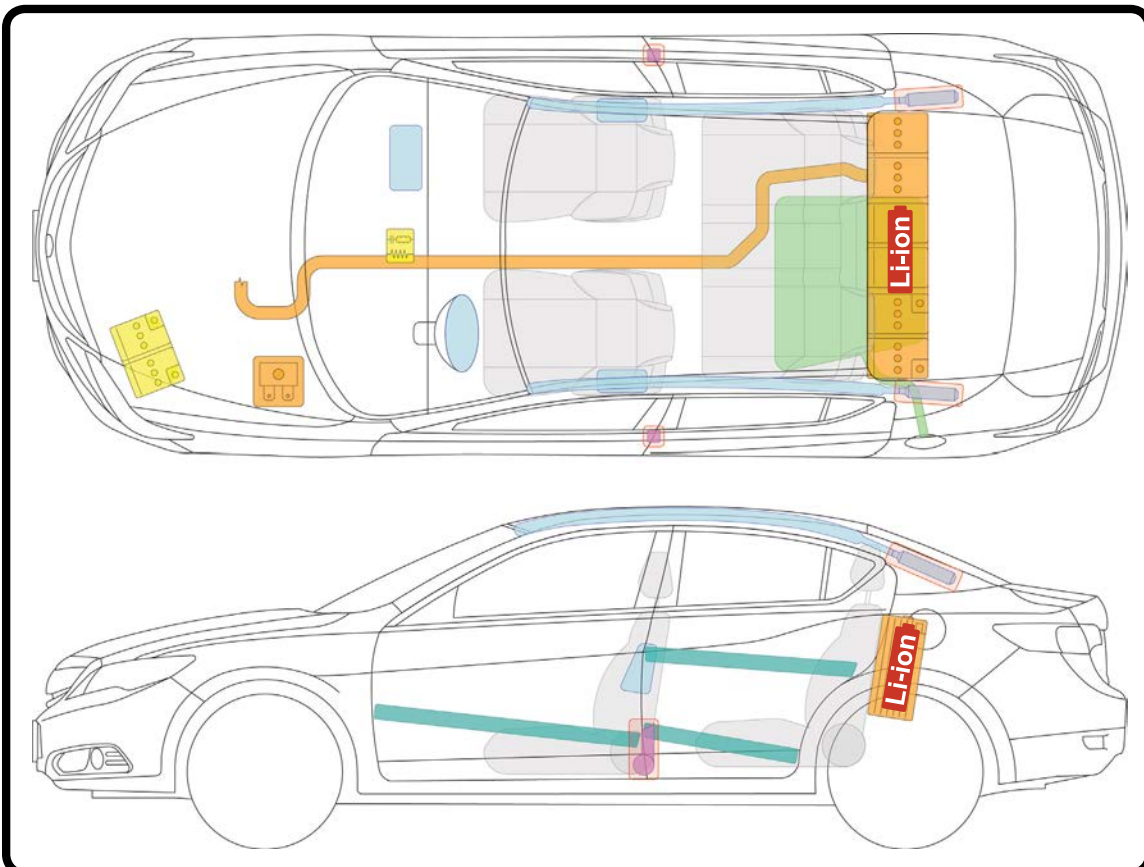

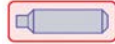

ILX

Li-ion (continued) **EXTRICATION INFORMATION**

See pages 15, 22.



LEGEND

 Airbag	 Bodywork Reinforcements	 SRS Control Unit
 Stored Gas Inflator	 Support Cylinder for Hood	 12V Battery
 Seatbelt Tensioner or Pretensioner	 Fuel Tank	 High-Voltage Power Cable
 High-Voltage Battery	 Emergency Disconnect (Remove Fuse)	

For towing and post-incident instructions, see the **POST-INCIDENT** section on page 20.

ACURA



2017-18

Hybrid

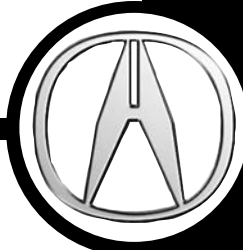

ACURA

ACURA

MDX

VEHICLE INFORMATION

Li-ion

See pages 15, 22.

IMMOBILIZE VEHICLE

1. **Chock the wheels.**
2. **Set parking brake.** (push button, center console)
3. **Place vehicle into park.** (gear selector, center console)

DISABLE VEHICLE

PRIMARY PROCEDURE

1. If ON, turn vehicle off by pressing POWER button for 2 seconds (right of steering column). Remove the proximity key at least 20 feet from vehicle.
2. Locate the 12V battery and (driver side, engine compartment) and cut or disconnect the negative cable.



Power Button

ALTERNATE PROCEDURE

(if the power button or proximity key is not accessible)

1. Locate the 12V battery (engine compartment driver side) and cut the negative cable.
2. Locate and cut the DC to DC converter cable. (When cutting the DC to DC converter cable, do not allow the cutting tool to contact any surrounding metal parts; electrical arcing could occur which can ignite any flammable vapors).

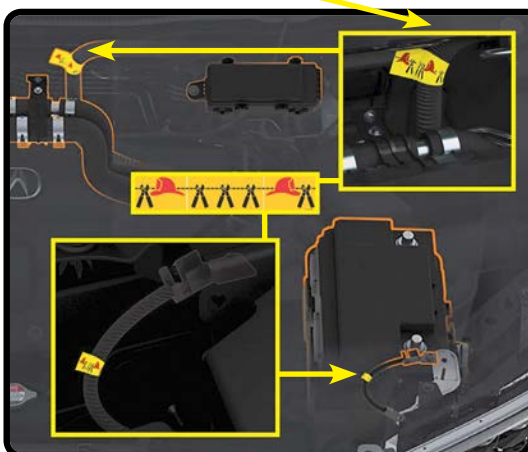

Cut the 12V Negative Battery Cable and DC to DC Converter Cable

NOTE: If you cannot do either method to stop the engine and prevent current flow into the high-voltage cables, use extreme care and do not touch damaged cables as they may be electrically charged.



If You Need to Cut The Hood To Open It, Be Sure To Stay Within The Cut Zone

WARNINGS

- NEVER cut, breach, or touch high voltage components or cabling. Doing so could result in serious injury or death.
- Airbags and SRS may remain powered for up to 3 minutes after shutoff/disabling. Avoid breaching SRS components.
- Lack of engine noise does not mean vehicle is OFF. Silent movement or instant restart capability exists until vehicle is fully shut down.

HEV

ACURA



2017-18

SH-AWD



MDX







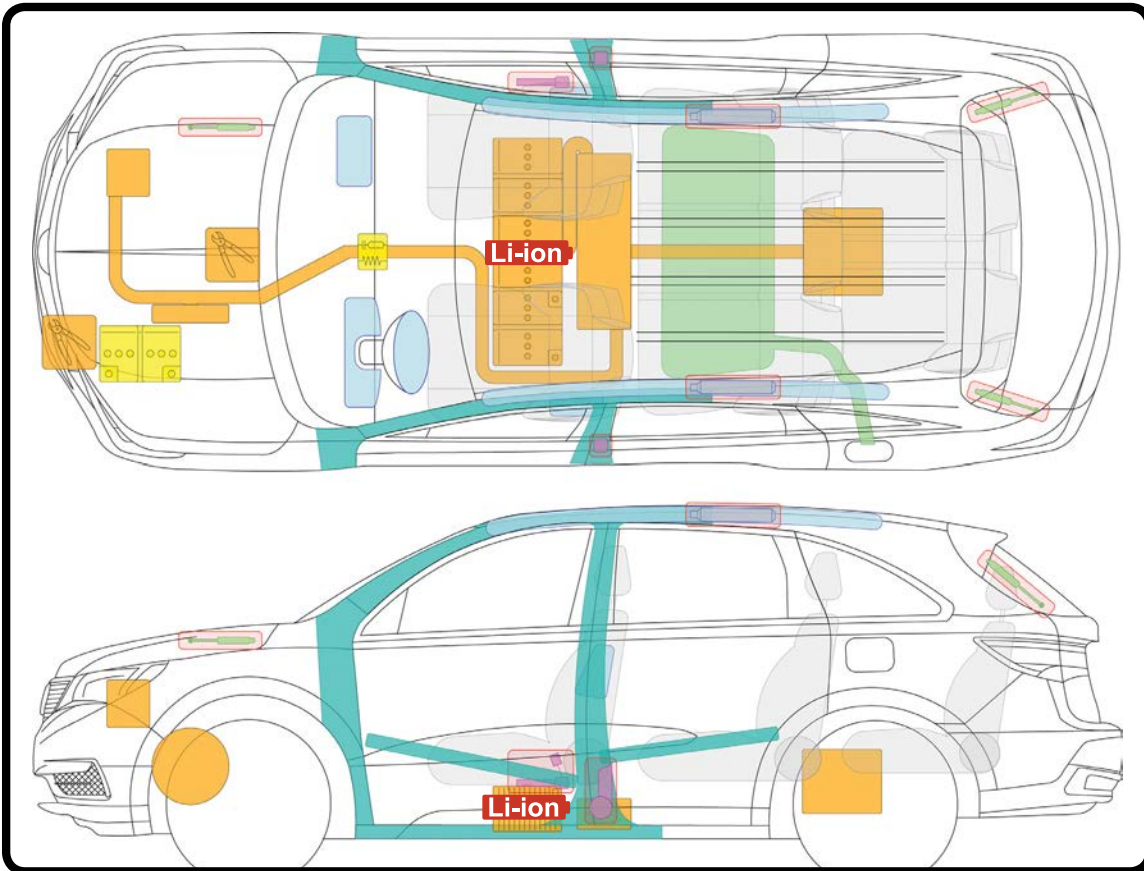

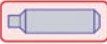

ACURA

Li-ion (continued) **EXTRICATION INFORMATION**

See pages 15, 22.



LEGEND

 Airbag	 Bodywork Reinforcements	 SRS Control Unit
 Stored Gas Inflator	 Support Cylinder for Hood	 12V Battery
 Seatbelt Tensioner or Pretensioner	 Fuel Tank	 High-Voltage Power Cable
 High-Voltage Battery	 Emergency Disconnect (Cut Cable)	

For towing and post-incident instructions, see the **POST-INCIDENT** section on page 20.



2017-18

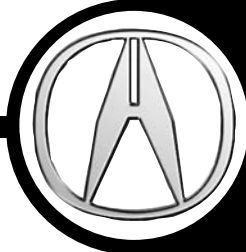

ACURA

VEHICLE INFORMATION

Li-ion

See pages 15, 22.

IMMOBILIZE VEHICLE

1. **Chock the wheels.**
2. **Set parking brake.**
(push button, center console)
3. **Place vehicle into park.**
(gear selector, center console)

DISABLE VEHICLE

PRIMARY PROCEDURE

1. If ON, turn vehicle off by pressing START/STOP button for 3 seconds (right of steering column). Remove the proximity key at least 20 feet from vehicle.
2. Locate the 12V battery and (driver side, engine compartment) and cut or disconnect the negative cable.



Power Button

ALTERNATE PROCEDURE

(if the power button or proximity key is not accessible)

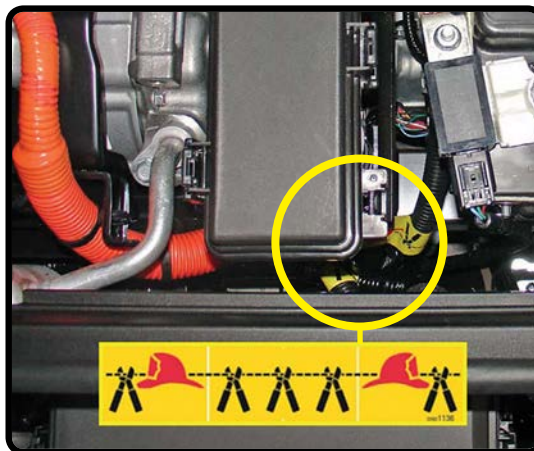

1. Locate the 12V battery (engine compartment driver side) and cut the negative cable.
2. Locate and cut the DC to DC converter cable. (When cutting the DC to DC converter cable, do not allow the cutting tool to contact any surrounding metal parts; electrical arcing could occur which can ignite any flammable vapors).



Cut the 12V Negative Battery Cable and DC to DC Converter Cable

NOTE: If you cannot do either method to stop the engine and prevent current flow into the high-voltage cables, Use extreme care and do not touch damaged cables as they may be electrically charged.

WARNINGS

-  NEVER cut, breach, or touch high voltage components or cabling. Doing so could result in serious injury or death.
-  Airbags and SRS may remain powered for up to 3 minutes after shutoff/disabling. Avoid breaching SRS components.
-  Lack of engine noise does not mean vehicle is OFF. Silent movement or instant restart capability exists until vehicle is fully shut down.

ACURA

NSX

HEV

ACURA



2017-18



NSX

ACURA

Li-ion (continued) **EXTRICATION INFORMATION**

See pages 15, 22.

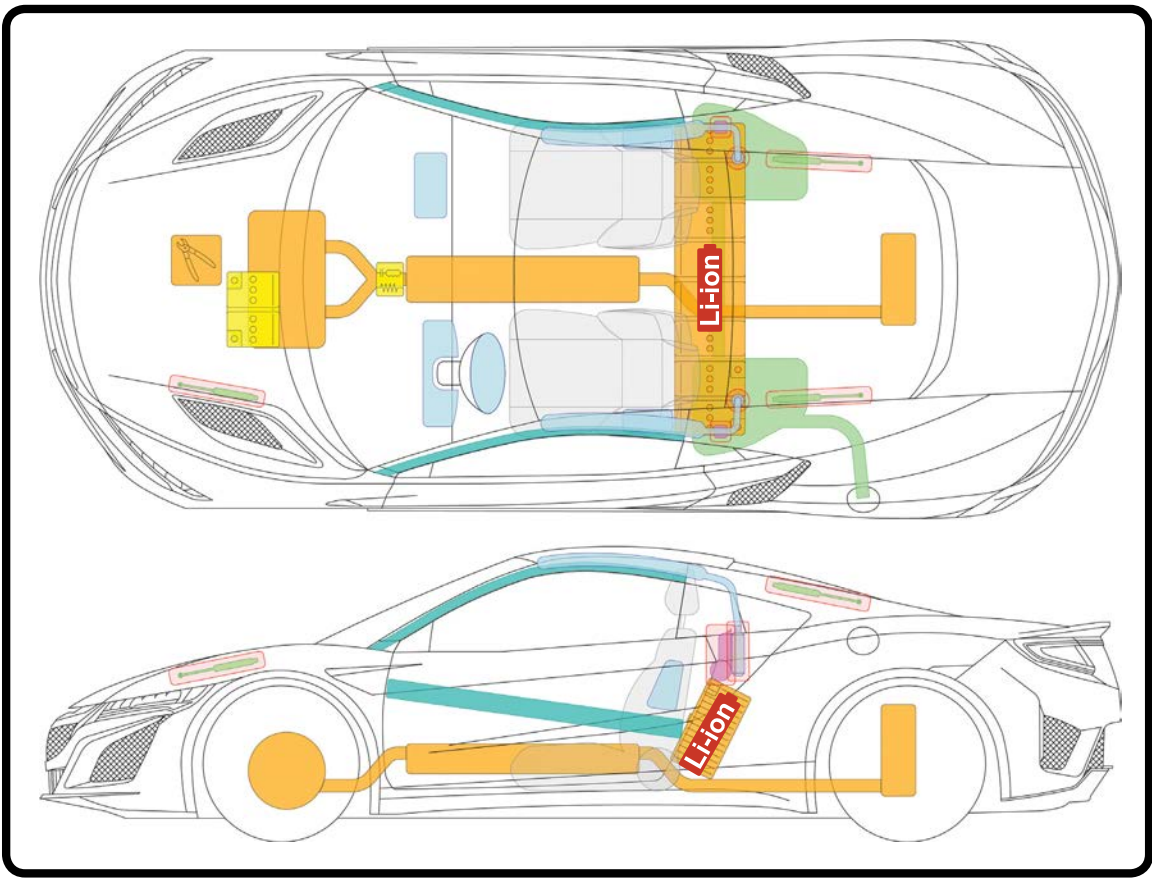

LEGEND		
Airbag	Bodywork Reinforcements	SRS Control Unit
Stored Gas Inflator	Support Cylinder for Hood	12V Battery
Seatbelt Tensioner or Pretensioner	Fuel Tank	High-Voltage Power Cable
High-Voltage Battery	Emergency Disconnect (Cut Cable)	

For towing and post-incident instructions, see the **POST-INCIDENT** section on page 20.



2014,16-17

2018

2014,16-18

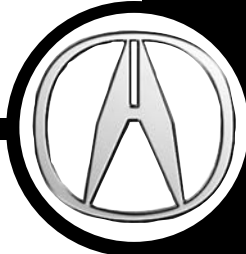

ACURA

ACURA

RLX

VEHICLE INFORMATION

Li-ion

See pages 15, 22.

IMMOBILIZE VEHICLE

1. **Chock the wheels.**
2. **Set parking brake.**
(pull-up switch, center console)
3. **Place vehicle into park.**
(gear selector, center console)

DISABLE VEHICLE

PRIMARY PROCEDURE

1. If ON, turn vehicle off by pressing START/STOP button for 3 seconds (right of steering column). Remove the proximity key at least 20 feet from vehicle.
2. Locate the 12V battery and (driver side, engine compartment) and cut or disconnect the negative cable.



Start Button

ALTERNATE PROCEDURE

(if the ignition button is not accessible)

1. Locate the 12V battery (engine compartment driver side) and cut the negative cable.
2. Locate and cut the DC to DC converter cable. (When cutting the DC to DC converter cable, do not allow the cutting tool to contact any surrounding metal parts; electrical arcing could occur which can ignite any flammable vapors).

NOTE: If you cannot perform either method to stop the engine and prevent current flow into the HV cables, use extreme care, do not cut into the cables, and do not touch damaged cables as they may be "hot."

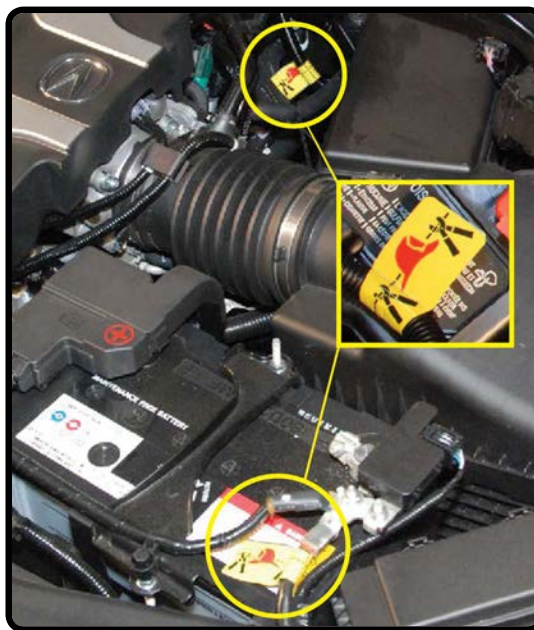

Cut the 12V Negative Battery Cable and DC to DC Converter Cable

WARNINGS

- NEVER cut, breach, or touch high voltage components or cabling. Doing so could result in serious injury or death.
- Airbags and SRS may remain powered for up to 3 minutes after shutoff/disabling. Avoid breaching SRS components.
- Lack of engine noise does not mean vehicle is OFF. Silent movement or instant restart capability exists until vehicle is fully shut down.

HEV

ACURA



2014,16-18



SH-AWD

2014,16-17

2018

RLX

Li-ion (continued) **EXTRICATION INFORMATION**
See pages 15, 22.

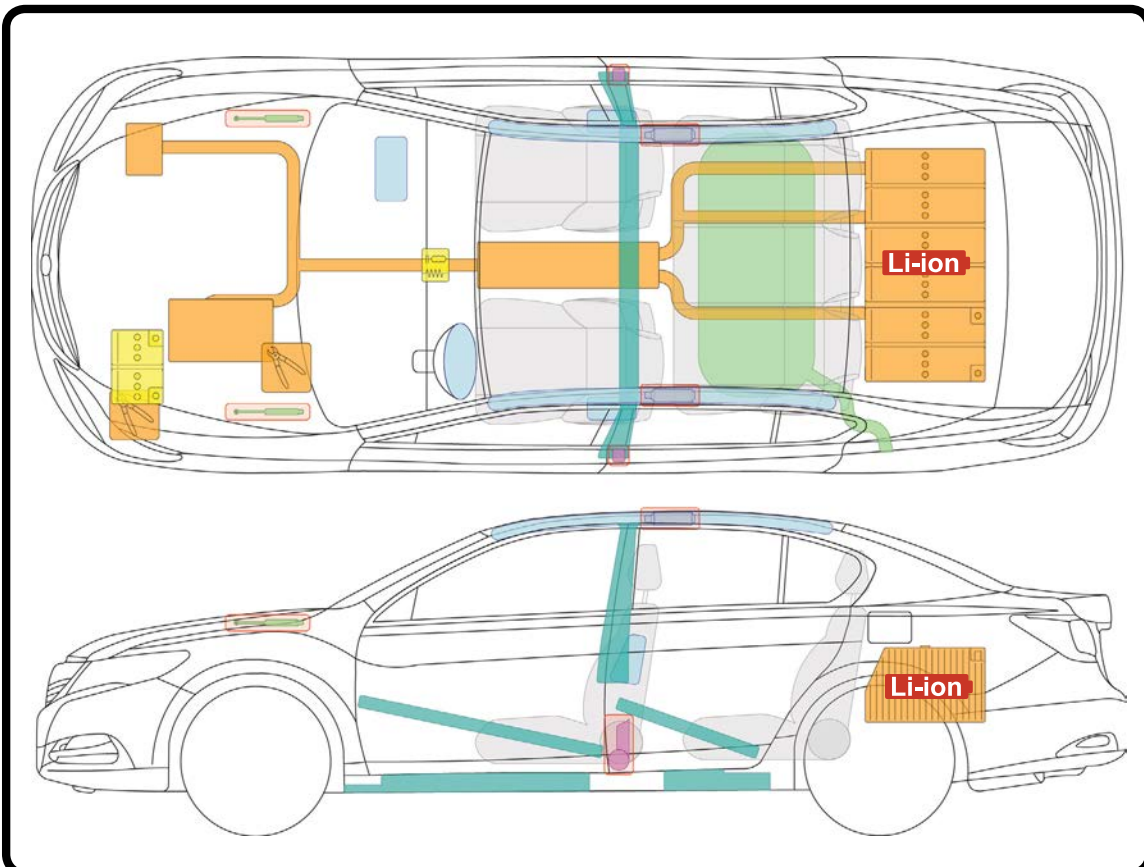

LEGEND

Airbag	Bodywork Reinforcements	SRS Control Unit
Stored Gas Inflator	Support Cylinder for Hood	12V Battery
Seatbelt Tensioner or Pretensioner	Fuel Tank	High-Voltage Power Cable
High-Voltage Battery	Emergency Disconnect (Cut Cable)	

For towing and post-incident instructions, see the **POST-INCIDENT** section on page 20.

ACURA



2016-18



e-tron

VEHICLE INFORMATION

Li-ion

See pages 15, 22.

IMMOBILIZE VEHICLE

1. **Chock the wheels.**
2. **Set parking brake.**
(pull switch, center console)
3. **Place vehicle into park.**
(gear selector, center console)

DISABLE VEHICLE

Determine if vehicle is ON by instrument gauge pointing to READY. (Needle will point to OFF if shut down.)



Ready Indicator



Start Button

PRIMARY PROCEDURE

1. Press START ENGINE STOP button without depressing brake pedal. Take proximity key 15 feet (5 meters) away.
2. Lift the luggage compartment floor and disconnect the 12V battery cables.



Remove Luggage Compartment Floor

ALTERNATE PROCEDURE 1

1. Lift the luggage compartment floor and disconnect the 12V battery cables.
2. Locate and disconnect the HV emergency disconnect under the hood.



Disconnect HV Emergency Disconnect

ALTERNATE PROCEDURE 2

1. Lift the luggage compartment floor and disconnect the 12V battery cables.
2. Locate fuse box (left of steering wheel) and remove emergency fuse.



Fuse Box Left of Steering Column



Remove Emergency Fuse

WARNINGS

- NEVER cut, breach, or touch high voltage components or cabling. Doing so could result in serious injury or death.
- Lack of engine noise does not mean vehicle is OFF. Silent movement or instant restart capability exists until vehicle is fully shut down.

Audi
Audi
A3 Sportback



2016-18

e-tron



AUDI

A3 Sportback

Audi

Li-ion (continued) **EXTRICATION INFORMATION**

See pages 15, 22.

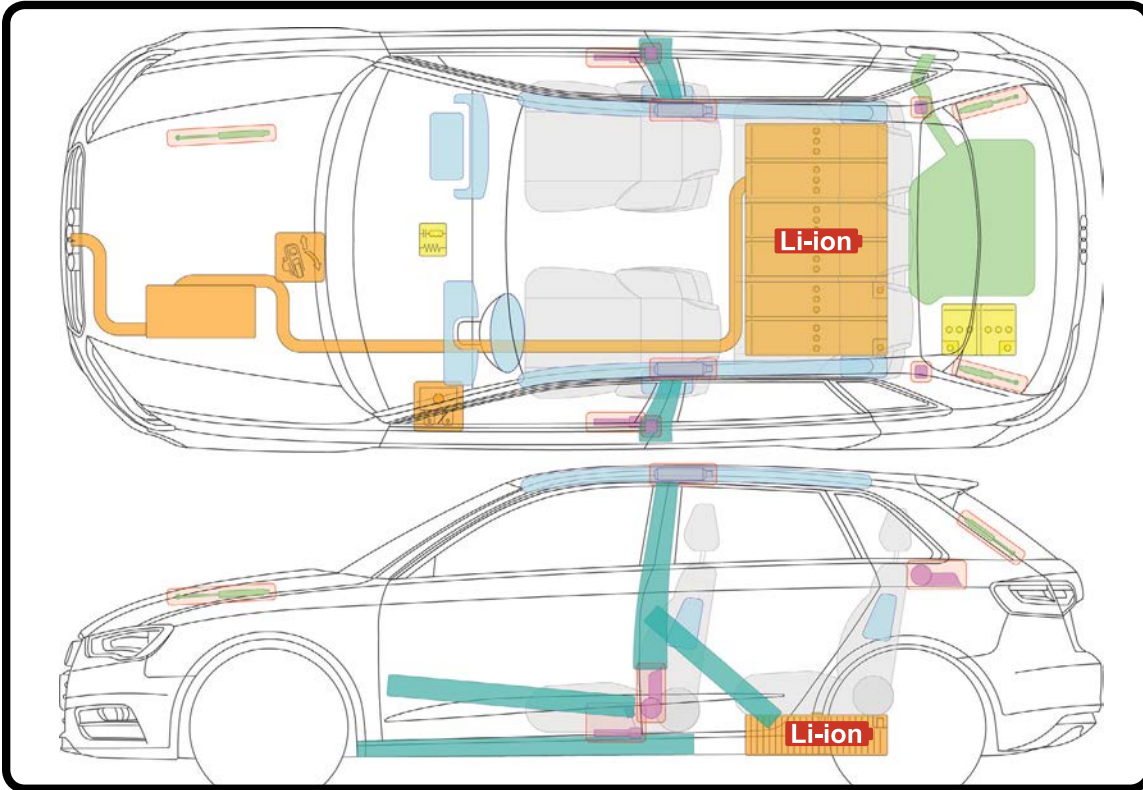

LEGEND		
Airbag	Bodywork Reinforcements	SRS Control Unit
Stored Gas Inflator	Support Cylinder for Hood	12V Battery
Seatbelt Tensitoner or Pretensioner	Fuel Tank	High-Voltage Power Cable
High-Voltage Battery	Emergency Disconnect (Remove Plug)	Emergency Disconnect (Remove Fuse)

A PLUGGED IN VEHICLE

If the vehicle is plugged in for charging, first unlock the doors via remote control or switch and then unplug the charging cable.



For towing and post-incident instructions, see the **POST-INCIDENT** section on page 20.



2013-16



hybrid

VEHICLE INFORMATION

Li-ion

See pages 15, 22.

IMMOBILIZE VEHICLE

1. **Chock the wheels.**
2. **Set parking brake.**
(hand brake, center console)
3. **Place vehicle into park.**
(gear selector, center console)

DISABLE VEHICLE

Determine if vehicle is ON by instrument gauge pointing to READY. (Needle will point to OFF if shut down.)

PRIMARY PROCEDURE

1. Switch off the ignition.
 - **With key in the ignition:**
Press the key into the ignition lock without depressing brake pedal. Pull out the key.
 - **With key not in the ignition:**
Press START ENGINE STOP button without depressing brake pedal. Take the proximity key 15 feet away.
2. Release the luggage compartment floor and disconnect the ground cables from **BOTH** 12V batteries (see below on how to access the 12V batteries).



Ready Indicator

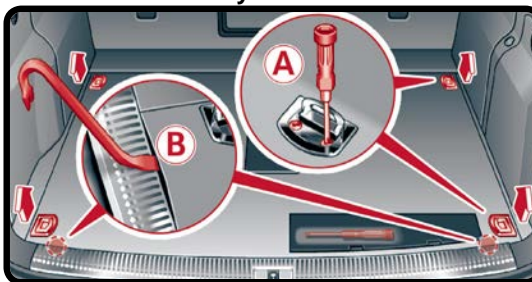

Remove Luggage Compartment Floor

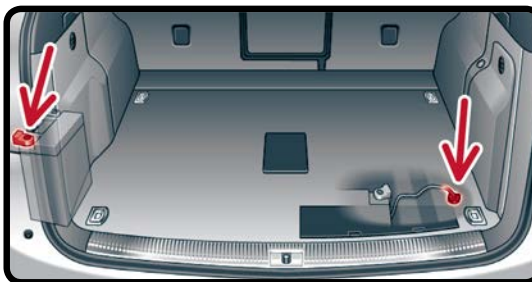



Disconnect the Ground Cables

ACCESSING THE 12V BATTERIES

1. Either use a screwdriver to remove the luggage compartment floor or pry up the luggage compartment floor by inserting a crowbar at the points indicated. Lift up the luggage compartment floor. Disconnect the ground cables from **BOTH** 12V batteries.

WARNINGS

-  NEVER cut, breach, or touch high voltage components or cabling. Doing so could result in serious injury or death.
-  There are two 12V batteries, both of which are located in the trunk (luggage compartment).
-  Lack of engine noise does not mean vehicle is OFF. Silent movement or instant restart capability exists until vehicle is fully shut down.

Audi

AUDI

Q5

HEV



2013-16

hybrid



AUDI

Q5

Li-ion







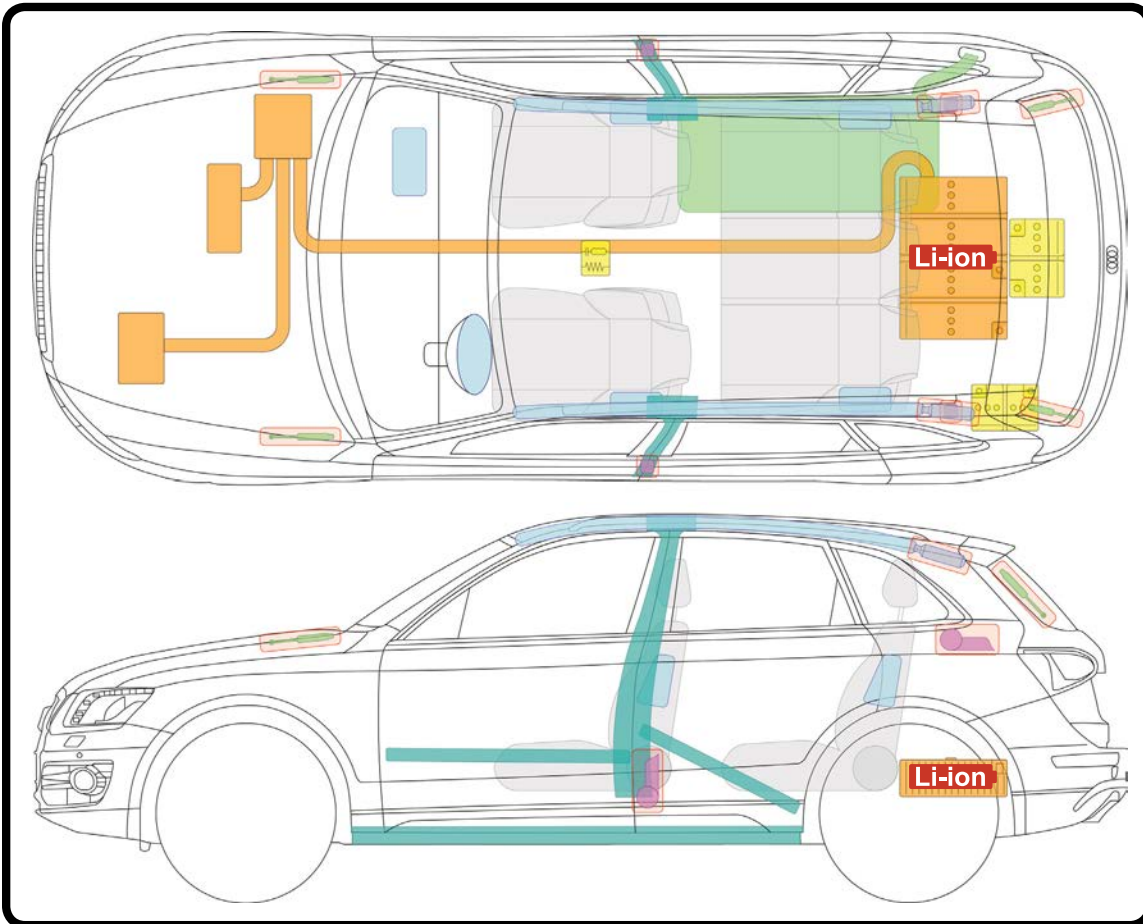



See pages 15, 22.

(continued)

EXTRICATION INFORMATION

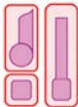

LEGEND

 Airbag	 Bodywork Reinforcements	 SRS Control Unit
 Stored Gas Inflator	 Support Cylinder for Hood	 12V Battery
 Seatbelt Tensioner or Pretensioner	 Fuel Tank	 High-Voltage Power Cable
 High-Voltage Battery		

For towing and post-incident instructions, see the **POST-INCIDENT** section on page 20.

Audi



2008-11

AZD



VEHICLE INFORMATION

IMMOBILIZE VEHICLE

- 1. Chock the wheels.
- 2. Set parking brake. (foot pedal)
- 3. Place vehicle into park. (shift lever)

DISABLE VEHICLE

PRIMARY PROCEDURE

- 1. Turn the ignition key to the OFF position and remove key.
- 2. Disconnect the negative cable (black) on the 12V battery (engine compartment, passenger side)
- 3. Disconnect the negative cable on the 2nd 12V battery (inside the frame rails, if installed).
- 4. Disconnect the low voltage connector from the front of the HV battery (mounted on the frame rail at the middle of the vehicle on the passenger side). Turn counter-clockwise 1/4 turn and pull it out.

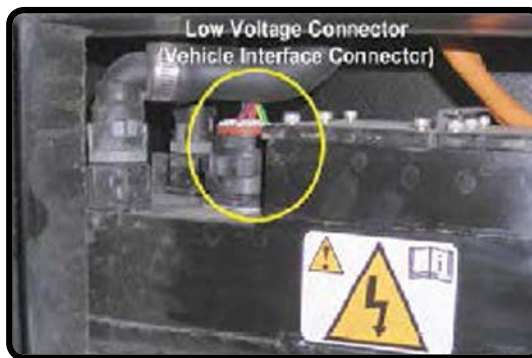

Disconnect the Low Voltage Connector Underneath the Front Edge of HV Battery

NOTE: This model can be found with either a Lithium Ion or NiMH battery onboard.

WARNINGS

- NEVER cut, breach, or touch high voltage components or cabling. Doing so could result in serious injury or death.
- If the HV battery was damaged physically or electrically during an accident, there is a possibility that high voltage may still be present on the orange cables even after the 12V battery is disconnected.
- Various components in the hybrid system contain capacitors that can store high voltage charges for several minutes after the HV system is shutdown.
- Lack of engine noise does not mean vehicle is OFF. Silent movement or instant restart capability exists until vehicle is fully shut down.





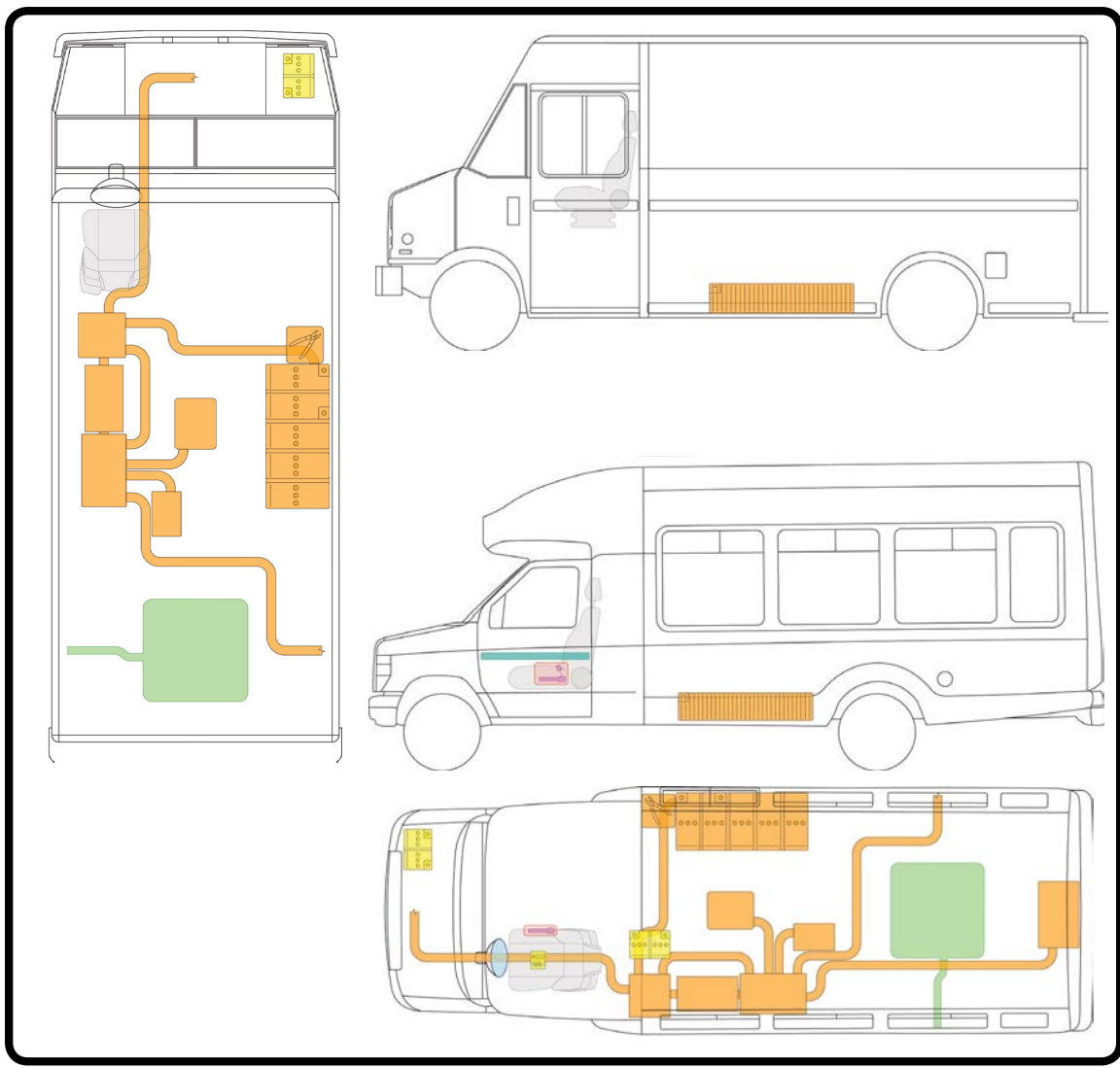

AZURE DYNAMICS BALANCE

AZURE

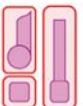

(continued) **EXTRICATION INFORMATION**

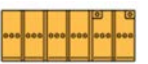

LEGEND		
 Airbag	 Bodywork Reinforcements	 SRS Control Unit
 Seatbelt Tensioner or Pretensioner	 Fuel Tank	 High-Voltage Power Cable
 High-Voltage Battery	 Emergency Disconnect (Cut Cable)	 12V Battery

For towing and post-incident instructions, see the **POST-INCIDENT** section on page 20.



2010-12

AZD

VEHICLE INFORMATION

IMMOBILIZE VEHICLE

- 1. **Chock the wheels.**
- 2. **Set parking brake.**
(hand brake, center console)
- 3. **Place vehicle into park.**
(gear selector, center console)

DISABLE VEHICLE

PRIMARY PROCEDURE

- 1. Turn the ignition key to the OFF position and remove key.
- 2. Disconnect the negative cable (black) on the 12V battery (engine compartment, driver's side)

ALTERNATE PROCEDURE



(if ignition key is inaccessible)

- 1. Disconnect 12V battery (engine compartment, driver's side) by using bolt cutters to cut both negative and positive cables.



Disconnect 12V Battery Negative Cable in Engine Compartment on Driver's Side

WARNINGS

-  NEVER cut, breach, or touch high voltage components or cabling. Doing so could result in serious injury or death.
-  The high voltage system may remain powered for up to 1 minute after shutoff/disabling. Avoid touching, cutting, or opening any orange high voltage cable or component.
-  This vehicle does not have an internal combustion engine. Lack of engine noise does not mean vehicle is OFF. Silent movement capability exists until vehicle is fully shut down.

AZURE DYNAMICS





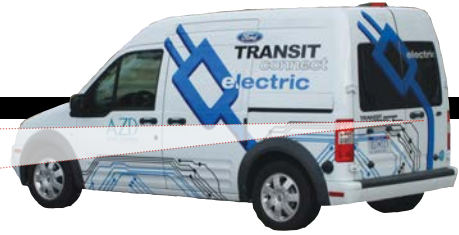

AZURE

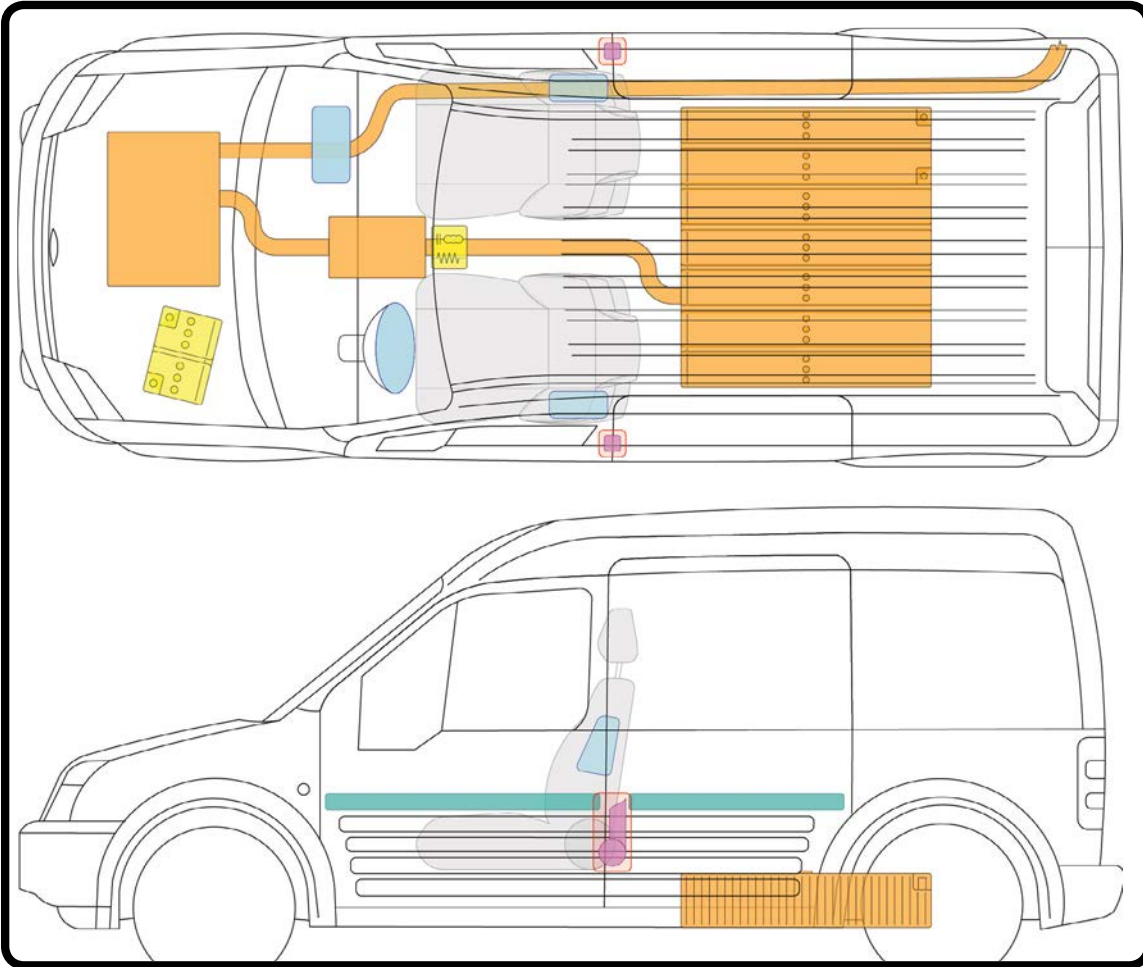
TRANSIT connect

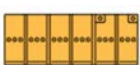

(continued) **EXTRICATION INFORMATION**

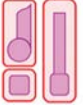

LEGEND		
 Airbag	 Bodywork Reinforcements	 SRS Control Unit
	 High-Voltage Battery	 12V Battery
 Seatbelt Tensioner or Pretensioner		 High-Voltage Power Cable

For towing and post-incident instructions, see the **POST-INCIDENT** section on page 20.



2016-18



BMW

BMW

3 SERIES

VEHICLE INFORMATION

Li-ion

See pages 15, 22.

IMMOBILIZE VEHICLE

1. **Chock the wheels.**
2. **Set parking brake.**
(hand brake, center console)
3. **Place vehicle into park.**
(push-button on top of gear lever)

DISABLE VEHICLE

Determine if vehicle is ON by right instrument gauge needle pointing to the READY position.

PRIMARY PROCEDURE

1. If ON, turn the vehicle's ignition off by pressing the Start/Stop button.
2. Remove proximity key and keep it at least 16 feet from the vehicle.
3. Disconnect 12V negative terminal on rear battery (behind right side trim panel in trunk).
4. Disconnect (1) connector lock (red) and (2) pull apart high voltage connection (behind right side trim panel in trunk).
5. Disconnect 12V negative terminal on front battery (drivers side of engine compartment under cover).



12V Battery Disconnect in Trunk

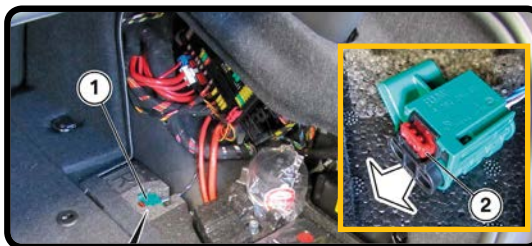

HV Connector Lock in Trunk



12V Battery Disconnect In Front



Emergency Response Cut Loop

ALTERNATE PROCEDURE

(if connector lock in trunk is not accessible)

1. Disconnect 12V negative terminal on rear battery (behind right side trim panel in trunk).
2. Disconnect 12V negative terminal on front battery (drivers side of engine compartment under cover).
3. Cut emergency response loop under hood (passenger's side).

NOTE: If the connector lock and 12v battery in trunk are not accessible. Steps 2 and 3 will result in the HV system being shut down but may not disable the airbag system.

WARNINGS



NEVER cut, breach, or touch high voltage components or cabling (orange coating). Doing so could result in serious injury or death.



The SRS system (airbags, etc.) may remain powered for up to 1 minute after disabling.



Lack of engine noise does not mean vehicle is OFF. Silent movement capability exists until vehicle is fully shut down.

PHEV



2016-18



E SERIES

Li-ion (continued) **EXTRICATION INFORMATION**

See pages 15, 22.

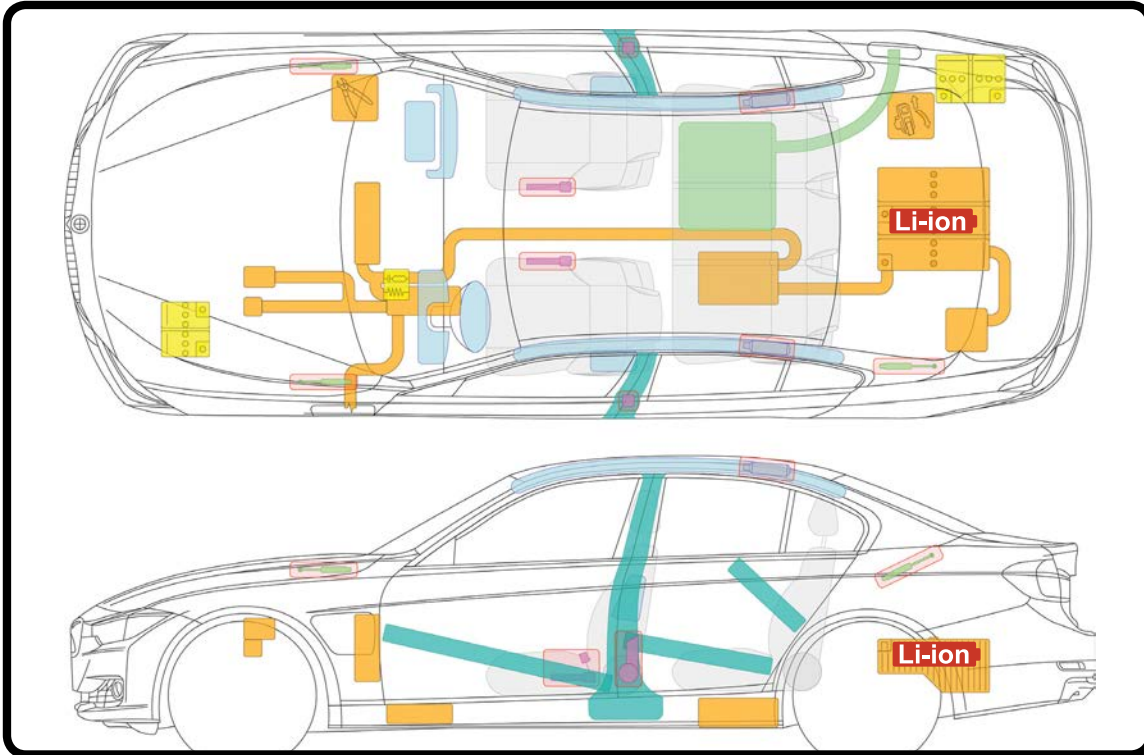

LEGEND		
Airbag	Bodywork Reinforcements	SRS Control Unit
Stored Gas Inflator	Support Cylinder for Hood	12V Battery
Seatbelt Tensioner or Pretensioner	Fuel Tank	High-Voltage Power Cable
High-Voltage Battery	Emergency Disconnect (Cut Cable)	Emergency Disconnect (Remove Plug)

A PLUGGED IN VEHICLE

If the vehicle is plugged in for charging, you should first unplug it. If access to unplug the vehicle is unavailable, “remove charge power” from the vehicle (done by turning off the power to the charge station).

For towing and post-incident instructions, see the **POST-INCIDENT** section on page 20.



Vehicle Charging Plug

BMW

BMW



2016-18



BMW

BMW

7 SERIES

VEHICLE INFORMATION

Li-ion

See pages 15, 22.

IMMOBILIZE VEHICLE

1. **Chock the wheels.**
2. **Set parking brake.**
(pull the "P" switch, center console)
3. **Place vehicle into park.**
(push-button on top of gear selector, center console)

DISABLE VEHICLE

Determine if vehicle is ON by right instrument gauge needle pointing to the READY position.

PRIMARY PROCEDURE

1. If ON, turn the vehicle's ignition off by pressing the Start/Stop button.
2. Remove proximity key and keep it at least 16 feet from the vehicle.
3. Disconnect the three 12V batteries at all three of the negative terminals (underneath luggage cover and compartment in trunk).
4. Disconnect the (2) connector lock (red) and (3) pull apart high voltage connection (behind right side trim panel in trunk). HV system is deactivated when the (4) bore is completely visible.

ALTERNATE PROCEDURE

(if connector lock in trunk is not accessible)

1. Disconnect the three 12V batteries at all three of the negative terminals (underneath luggage cover and compartment in trunk).
2. Cut emergency response loop under hood (passenger's side).

NOTE: If the connector lock and 12v batteries in trunk are not accessible. Step 2 will result in the HV system being shut down but may not disable airbag system.

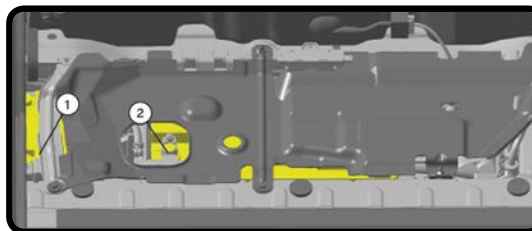

12V Battery Disconnect (1 & 2)

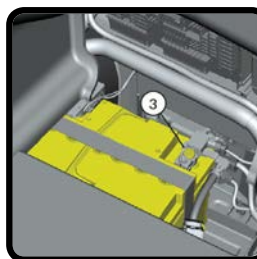

12V Battery Disconnect (3)



HV Connector Lock Right Side Trunk

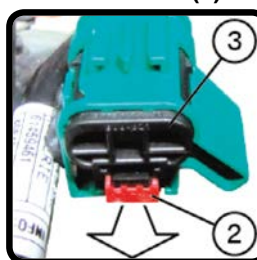

HV Connector Lock

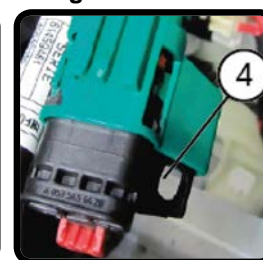

HV Deactivated



Emergency Response Cut Loop

WARNINGS



NEVER cut, breach, or touch high voltage components or cabling (orange coating). Doing so could result in serious injury or death.



Lack of engine noise does not mean vehicle is OFF. Silent movement capability exists until vehicle is fully shut down.

PHEV



2016-18



7 SERIES

Li-ion (continued) **EXTRICATION INFORMATION**

See pages 15, 22.

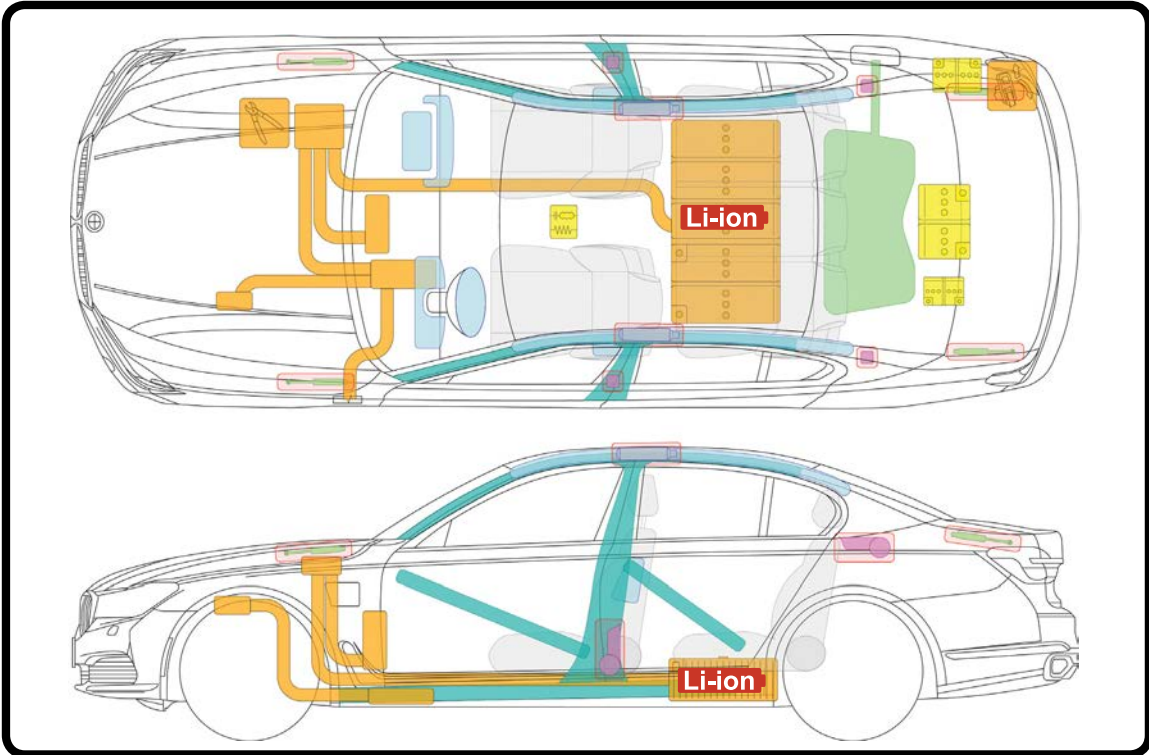

LEGEND		
Airbag	Bodywork Reinforcements	SRS Control Unit
Stored Gas Inflator	Support Cylinder for Hood	12V Battery
Seatbelt Tensioner or Pretensioner	Fuel Tank	High-Voltage Power Cable
High-Voltage Battery	Emergency Disconnect (Cut Cable)	Emergency Disconnect (Remove Plug)

A PLUGGED IN VEHICLE

If the vehicle is plugged in for charging, you should first unplug it. If access to unplug the vehicle is unavailable, “remove charge power” from the vehicle (done by turning off the power to the charge station).

For towing and post-incident instructions, see the **POST-INCIDENT** section on page 20.



Vehicle Charging Plug

BMW

BMW



2013-15



Active Hybrid

VEHICLE INFORMATION

Li-ion

See pages 15, 22.

IMMOBILIZE VEHICLE

1. **Chock the wheels.**
2. **Set parking brake.**
(hand brake, center console)
3. **Place vehicle into park.**
(push-button on top of gear lever)

DISABLE VEHICLE

Determine if vehicle is ON by presence of READY indicator on the bottom left of tachometer. Some variants may have an OFF indication if the vehicle is off.

PRIMARY PROCEDURE

1. If ON, turn the vehicle's ignition off by Pressing the start/stop button. Remove key.
2. Open the trunk and remove the service flap from luggage compartment trim panel on the right.
3. Loosen the nuts and pull the battery earth leads (1) out toward the top. Cover the battery earth lead, in order to prevent contact to the battery terminals.

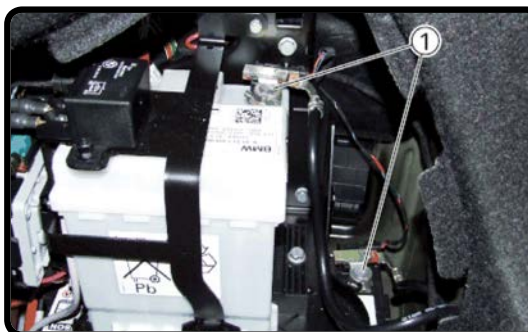

12V Battery

ALTERNATE PROCEDURE

1. Remove luggage compartment floor trim panel (trunk floor).
2. Unlock the HV safety connector and pull apart in the direction of the arrow.

NOTE: The plug connection cannot be fully disconnected. You can install a padlock through the open bore hole (1) to prevent unintended activation of the HV system!

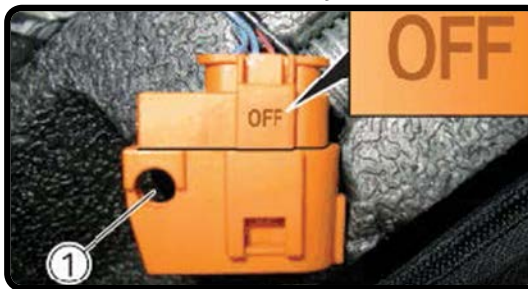

High Voltage Safety Connector

WARNINGS



NEVER cut, breach, or touch high voltage components or cabling (orange coating). Doing so could result in serious injury or death.



Lack of engine noise does not mean vehicle is OFF. Silent movement or instant restart capability exists until vehicle is fully shut down.

BMW

BMW

Active Hybrid 3

HEV



2013-15



Active Hybrid

Active Hybrid 3

Li-ion







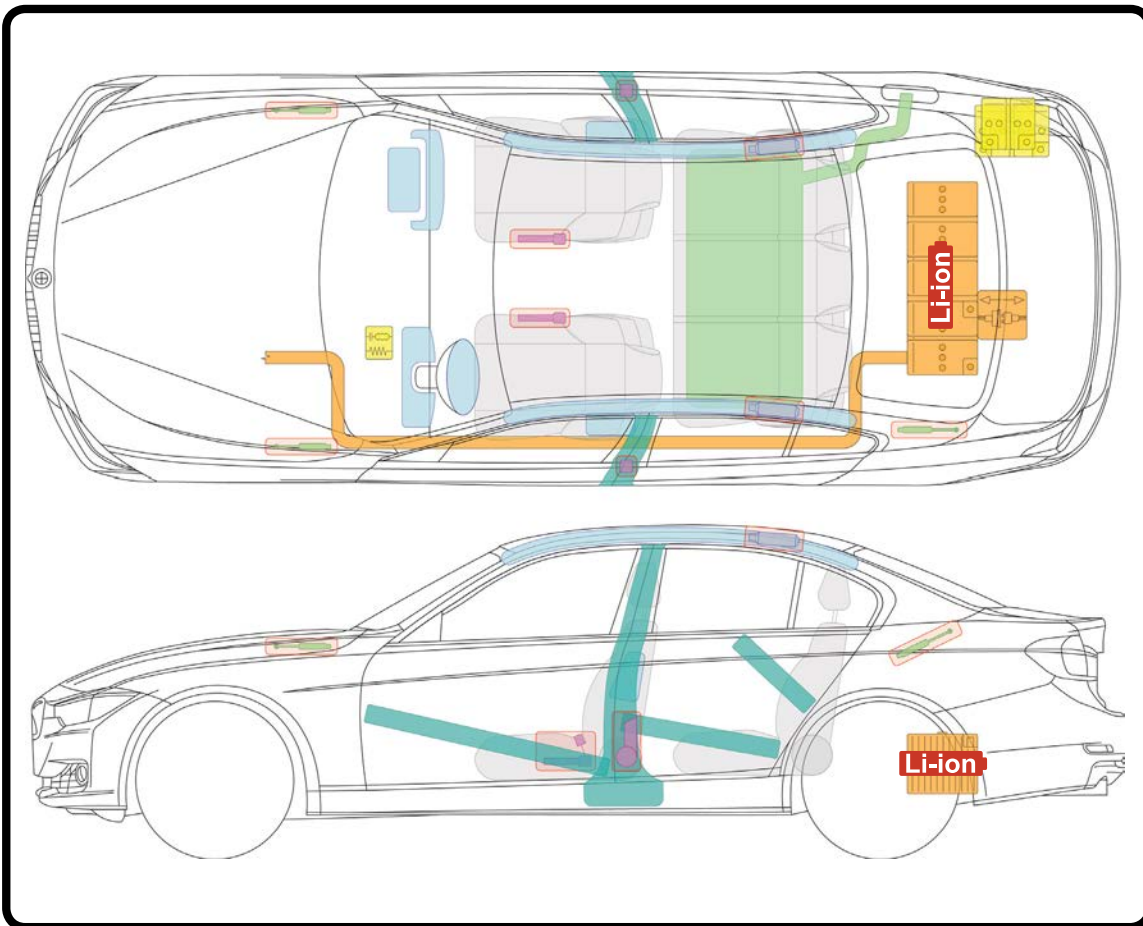

(continued)

EXTRICATION INFORMATION

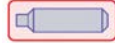
See pages 15, 22.

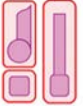

LEGEND

 Airbag	 Bodywork Reinforcements	 SRS Control Unit
 Stored Gas Inflator	 Support Cylinder for Hood	 12V Battery
 Seatbelt Tensioner or Pretensioner	 Fuel Tank	 High-Voltage Power Cable
 High-Voltage Battery	 Emergency Disconnect (Disconnect Plug)	

For towing and post-incident instructions, see the **POST-INCIDENT** section on page 20.

BMW

BMW



2013-16



Active Hybrid

VEHICLE INFORMATION

Li-ion

See pages 15, 22.

IMMOBILIZE VEHICLE

1. **Chock the wheels.**
2. **Set parking brake.**
(pull the "P" switch, center console)
3. **Place vehicle into park.**
(push-button on top of gear lever)

DISABLE VEHICLE

Determine if vehicle is ON by presence of READY indicator on the bottom left of tachometer. Some variants may have an OFF indication if the vehicle is off.

PRIMARY PROCEDURE

1. If ON, turn the vehicle's ignition off by Pressing the start/stop button.
2. If equipped with a proximity key, remove key and keep it at least 20 feet from the vehicle.
3. Open the trunk and fold the luggage compartment floor trim panel up. Loosen plastic nuts and remove luggage compartment floor trim panel.
3. Loosen the nut (1) and pull the battery earth lead (2) off toward the top.
- Cover the battery earth lead to prevent contact with the battery terminal.
4. Disconnect 12V auxiliary battery, negative terminal (trunk, right side).

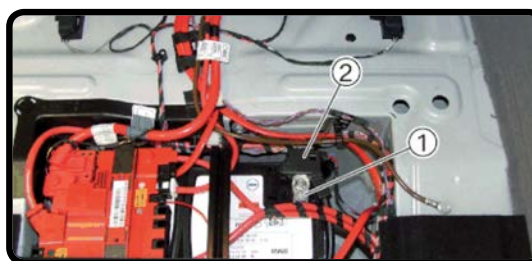

12V Main Battery Disconnect



12V Auxiliary Battery Negative Terminal

ALTERNATE PROCEDURE

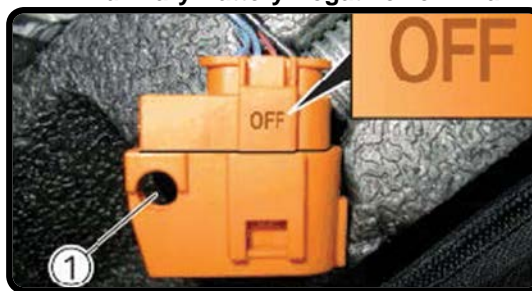

1. Remove service flap (trunk, right side).
2. Unlock the HV safety connector and pull apart.

NOTE: The plug connection cannot be fully disconnected. You can install a padlock through the open bore hole (1) to prevent unintended activation of the HV system!



High Voltage Safety Connector

WARNINGS

-  NEVER cut, breach, or touch high voltage components or cabling (orange coating). Doing so could result in serious injury or death.
-  There are two 12V batteries, both of which are located in the trunk (luggage compartment).
-  Lack of engine noise does not mean vehicle is OFF. Silent movement or instant restart capability exists until vehicle is fully shut down.

BMW

BMW

Active Hybrid 5

HEV



2013-16



Active Hybrid







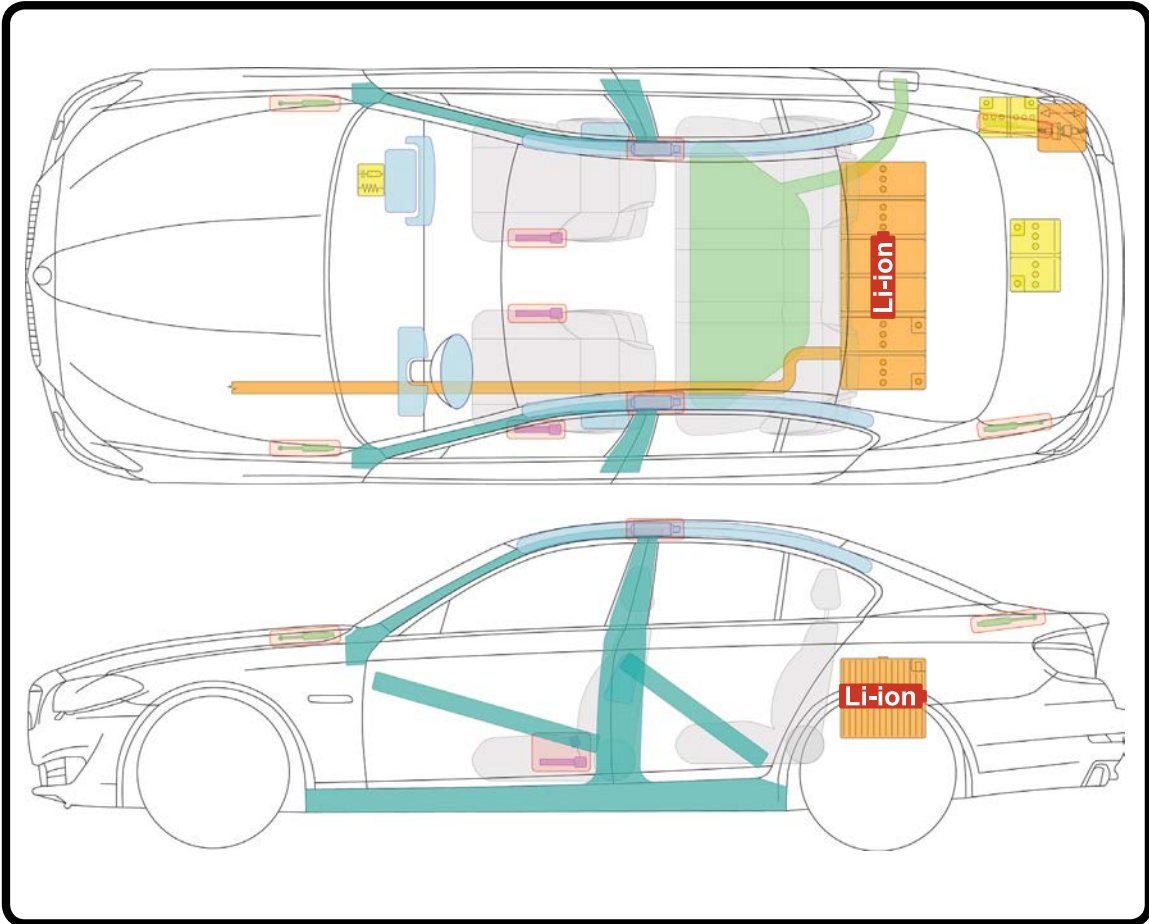

Active Hybrid 5

Li-ion (continued) **EXTRICATION INFORMATION**

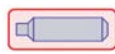
See pages 15, 22.

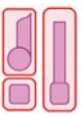

LEGEND

 Airbag	 Bodywork Reinforcements	 SRS Control Unit
 Stored Gas Inflator	 Support Cylinder for Hood	 12V Battery
 Seatbelt Tensioner or Pretensioner	 Fuel Tank	 High-Voltage Power Cable
 High-Voltage Battery	 Emergency Disconnect (Disconnect Plug)	

For towing and post-incident instructions, see the **POST-INCIDENT** section on page 20.



2010-12



Active Hybrid

VEHICLE INFORMATION

Li-ion
See pages 15, 22.

IMMOBILIZE VEHICLE

- 1. **Chock the wheels.**
- 2. **Set parking brake.**
(pull-up switch, center console)
- 3. **Place vehicle into park.**
(gear selector, center console)

DISABLE VEHICLE

Determine if vehicle is ON by presence of READY indicator on the bottom left of tachometer. Some variants may have an OFF indication if the vehicle is off.

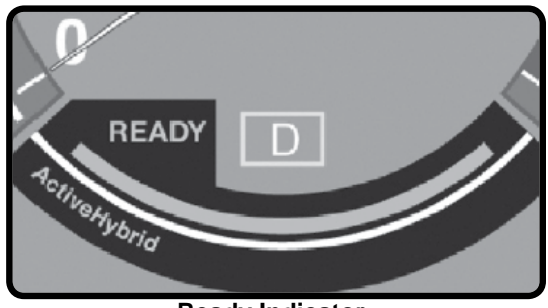

PRIMARY PROCEDURE

- 1. If ON, turn the vehicle's ignition off (push-button). Remove key.
- 2. Disconnect the 12V battery, negative terminal (in trunk).



Ready Indicator

WARNINGS

-  NEVER cut, breach, or touch high voltage components or cabling. Doing so could result in serious injury or death.
-  Lack of engine noise does not mean vehicle is OFF. Silent movement or instant restart capability exists until vehicle is fully shut down.

BMW

BMW

Active Hybrid 7

HEV



2010-12



Active Hybrid

Active Hybrid 7

Li-ion







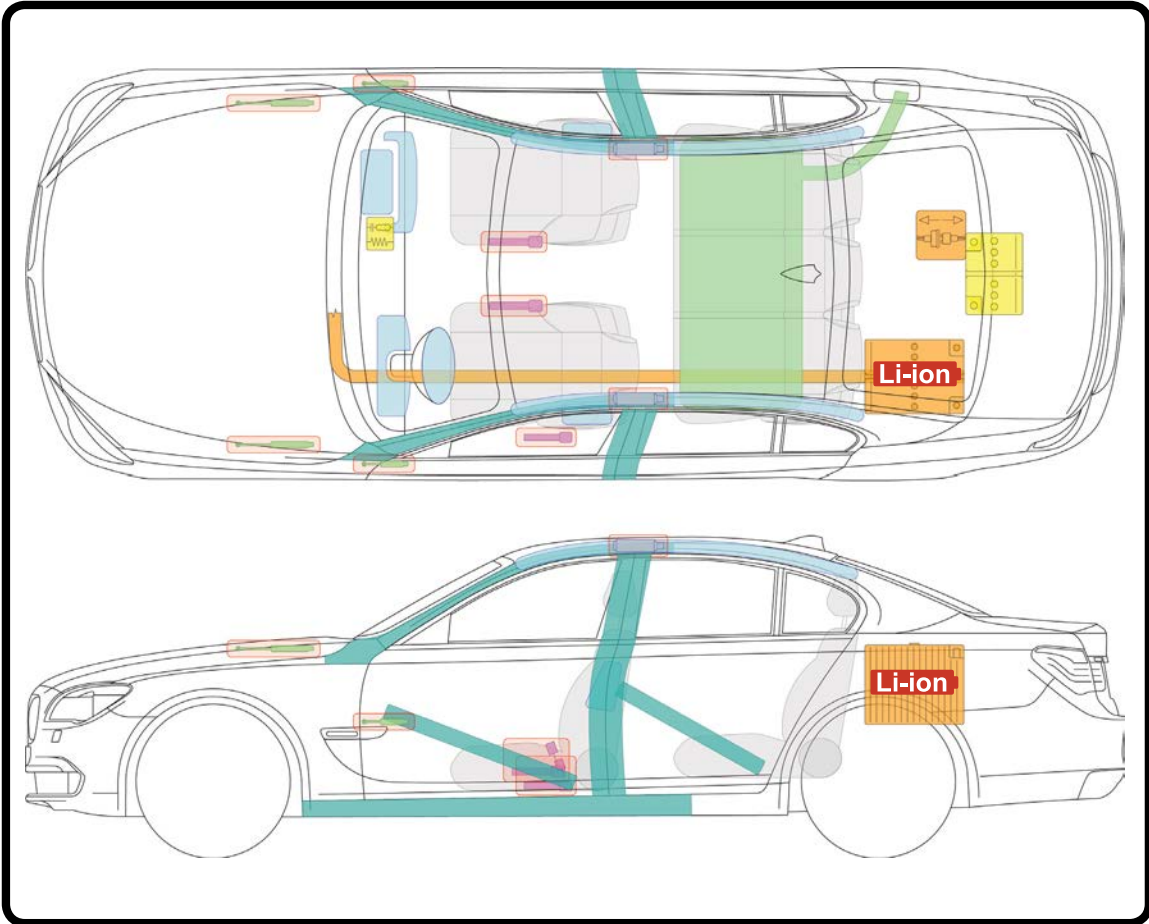

See pages 15, 22.

(continued)

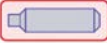
EXTRICATION INFORMATION

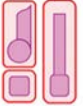

LEGEND

 Airbag	 Bodywork Reinforcements	 SRS Control Unit
 Stored Gas Inflator	 Support Cylinder for Hood	 12V Battery
 Seatbelt Tensioner or Pretensioner	 Fuel Tank	 High-Voltage Power Cable
 High-Voltage Battery	 Emergency Disconnect (Disconnect Plug)	

For towing and post-incident instructions, see the **POST-INCIDENT** section on page 20.



2013-15



Active Hybrid

BMW

VEHICLE INFORMATION

Li-ion

See pages 15, 22.

IMMOBILIZE VEHICLE

- 1. **Chock the wheels.**
- 2. **Set parking brake.**
(pull the "P" switch, center console)
- 3. **Place vehicle into park.**
(push-button on top of gear lever)

DISABLE VEHICLE

Determine if vehicle is ON by presence of READY indicator on the bottom left of tachometer. Some variants may have an OFF indication if the vehicle is off.

PRIMARY PROCEDURE

- 1. If ON, turn the vehicle's ignition off by Pressing the start/stop button. Remove key. If equipped with a proximity key, remove key and keep it at least 16 feet from the vehicle.
- 2. Open the trunk and fold the luggage compartment floor trim panel up. Loosen plastic nuts and remove luggage compartment floor trim panel.
- 3. Loosen the nut (1) and pull the battery earth lead (2) off toward the top. Cover the battery earth lead to prevent contact with the battery terminal.
- 4. Disconnect 12V auxiliary battery, negative terminal (trunk, right side).

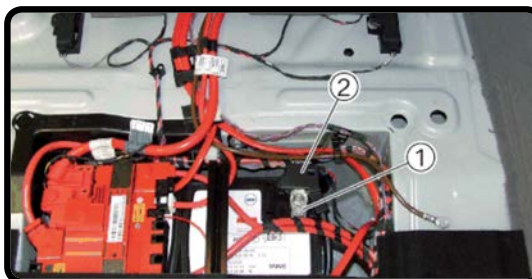

12V Main Battery Disconnect



12V Auxiliary Battery Negative Terminal

ALTERNATE PROCEDURE

- 1. Remove service flap (trunk, right side).
- 2. Unlock the HV safety connector and pull apart.

NOTE: The plug connection cannot be fully disconnected. You can install a padlock through the open bore hole (1) to prevent unintended activation of the HV system!

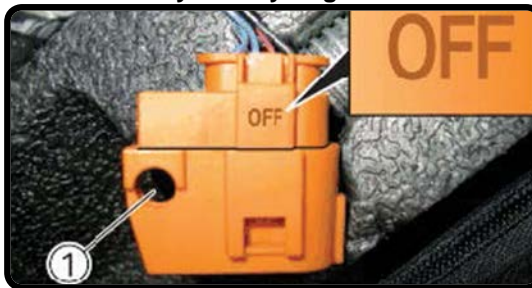

High Voltage Safety Connector

WARNINGS



NEVER cut, breach, or touch high voltage components or cabling (orange coating). Doing so could result in serious injury or death.



Lack of engine noise does not mean vehicle is OFF. Silent movement or instant restart capability exists until vehicle is fully shut down.

BMW

Active Hybrid 7

HEV



2013-15



Active Hybrid







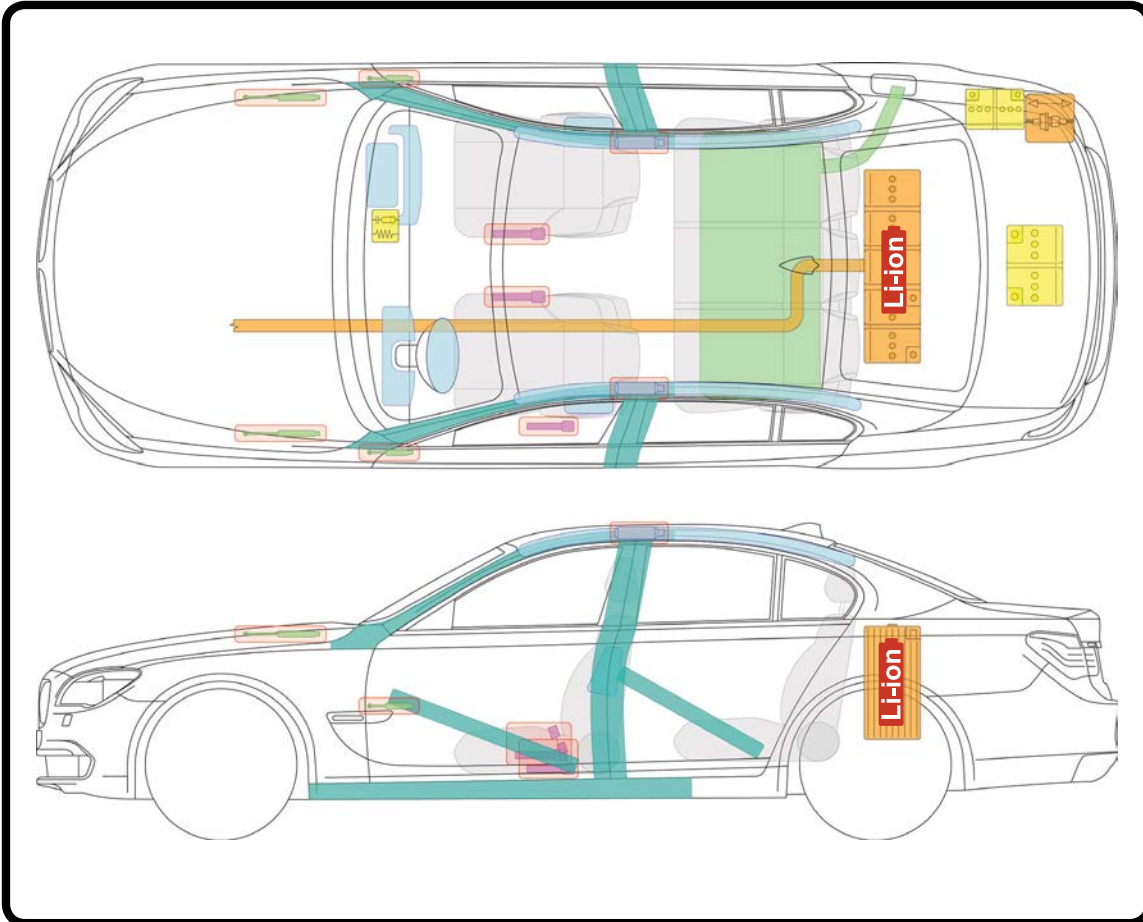

Active Hybrid 7

Li-ion (continued) **EXTRICATION INFORMATION**

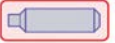
See pages 15, 22.

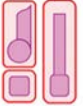

LEGEND

 Airbag	 Bodywork Reinforcements	 SRS Control Unit
 Stored Gas Inflator	 Support Cylinder for Hood	 12V Battery
 Seatbelt Tensioner or Pretensioner	 Fuel Tank	 High-Voltage Power Cable
 High-Voltage Battery		

For towing and post-incident instructions, see the **POST-INCIDENT** section on page 20.



2014-15



BMW

VEHICLE INFORMATION

Li-ion

See pages 15, 22.

IMMOBILIZE VEHICLE

- 1. **Chock the wheels.**
- 2. **Set parking brake.**
(pull the "P" switch, center console)
- 3. **Place vehicle into park.**
(push-button on top of gear lever, steering column)

DISABLE VEHICLE

Determine if vehicle is ON by presence of READY indicator near the tachometer.

PRIMARY PROCEDURE

- 1. If ON, turn the vehicle's ignition off by pressing the Start/Stop button.
- 2. Remove proximity key and keep it at least 16 feet from the vehicle.
- 3. Disconnect the 12V battery (underneath cover in engine compartment, passenger side) by slackening the nut (1) and pulling off the battery earth lead (2) in the upwards direction.
- 4. Access the HV disconnect (underneath cover in engine compartment, driver's side) and unlock the connector for the HV emergency separation point (1). Pull apart in direction of arrow.

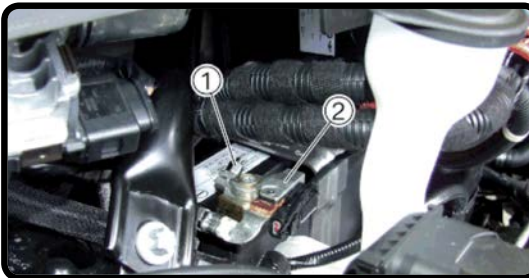

12V Battery Disconnect



HV Disconnect

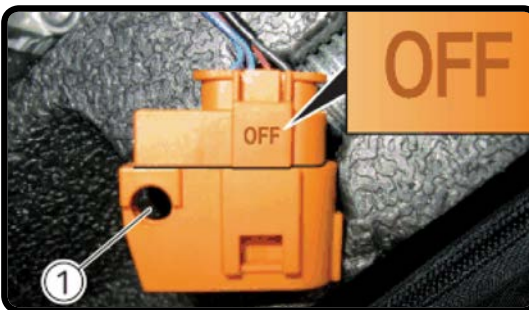

HV Disconnect in OFF Position

WARNINGS



NEVER cut, breach, or touch high voltage components or cabling (orange coating). Doing so could result in serious injury or death.



This vehicle does not have an internal combustion engine. Lack of engine noise does not mean vehicle is OFF. Silent movement capability exists until vehicle is fully shut down.

BMW

03



2014-15







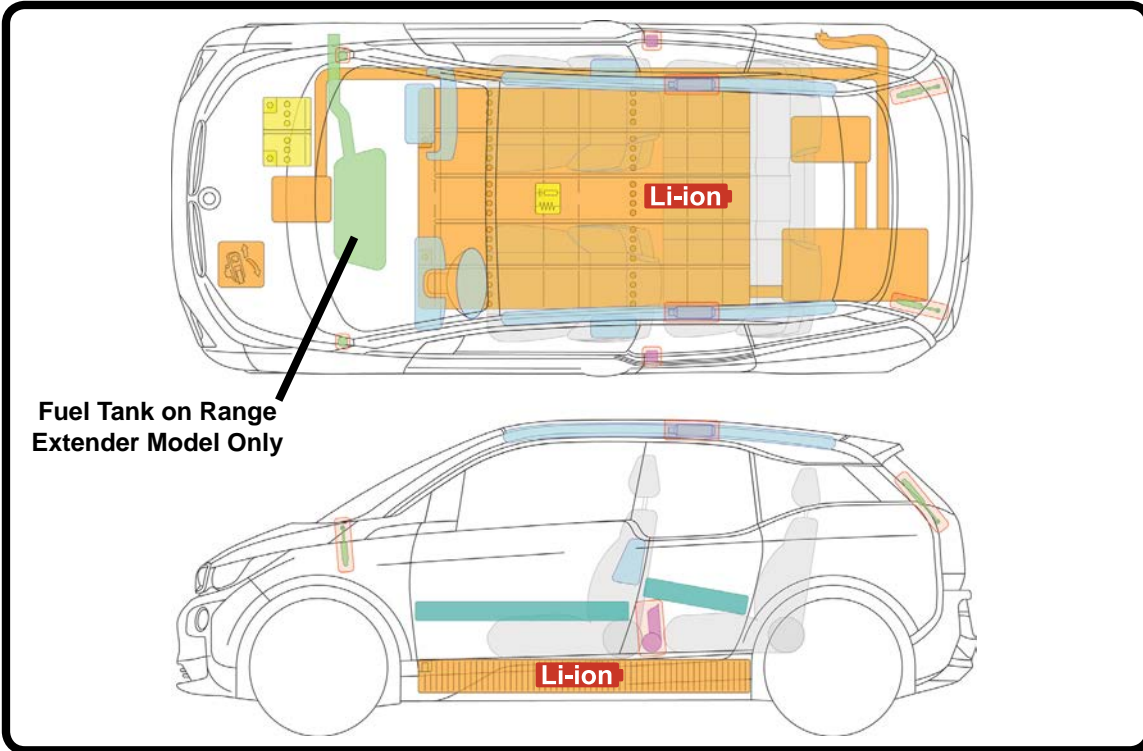





Li-ion (continued) **EXTRICATION INFORMATION**

See pages 15, 22.

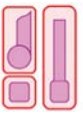

Fuel Tank on Range Extender Model Only

LEGEND		
 Airbag	 Bodywork Reinforcements	 SRS Control Unit
 Stored Gas Inflator	 Support Cylinder for Hood	 12V Battery
 Seatbelt Tensioner or Pretensioner	 Fuel Tank	 High-Voltage Power Cable
 High-Voltage Battery	 Emergency Disconnect (Remove Plug)	

SPECIAL CONCERNS

RANGE EXTENDER OPTION

Some models come with a range extender option that includes a gasoline generator and fuel storage. These models are considered extended range electric vehicles. Range extenders are located to the right of the HV disconnect.

For towing and post-incident instructions, see the **POST-INCIDENT** section on page 20.



2015-18



BMW

VEHICLE INFORMATION

Li-ion

See pages 15, 22.

IMMOBILIZE VEHICLE

- 1. **Chock the wheels.**
- 2. **Set parking brake.**
(pull the "P" switch, center console)
- 3. **Place vehicle into park.**
(push-button on top of gear lever, steering column)

DISABLE VEHICLE

Determine if vehicle is ON by presence of active display on tachometer.

PRIMARY PROCEDURE

- 1. If ON, turn the vehicle's ignition off by pressing the Start/Stop button.
- 2. Remove proximity key and keep it at least 16 feet from the vehicle.
- 3. Disconnect the 12V battery negative cable (underneath cover in engine compartment, passenger side).
- 4. Access the HV disconnect (underneath cover in engine compartment, driver's side) and unlock the connector for the HV emergency separation point (1). Pull apart in direction of arrow.



HV Disconnect

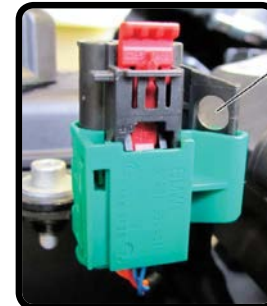

HV Disconnect in OFF Position

ALTERNATE PROCEDURE

- 1. Cut the second high voltage disconnect under the charging connection flap (rear of vehicle).
- 2. Disconnect the 12V battery negative cable (underneath cover in engine compartment, passenger side).



Charging Connection Flap

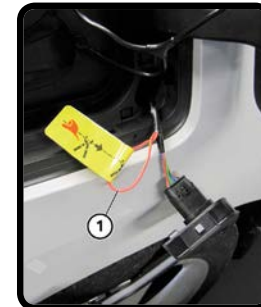

Alternate HV Disconnect

WARNINGS

- NEVER cut, breach, or touch high voltage components or cabling (orange coating). Doing so could result in serious injury or death.
- This vehicle does not have an internal combustion engine. Lack of engine noise does not mean vehicle is OFF. Silent movement capability exists until vehicle is fully shut down.

BMW

03



2015-18









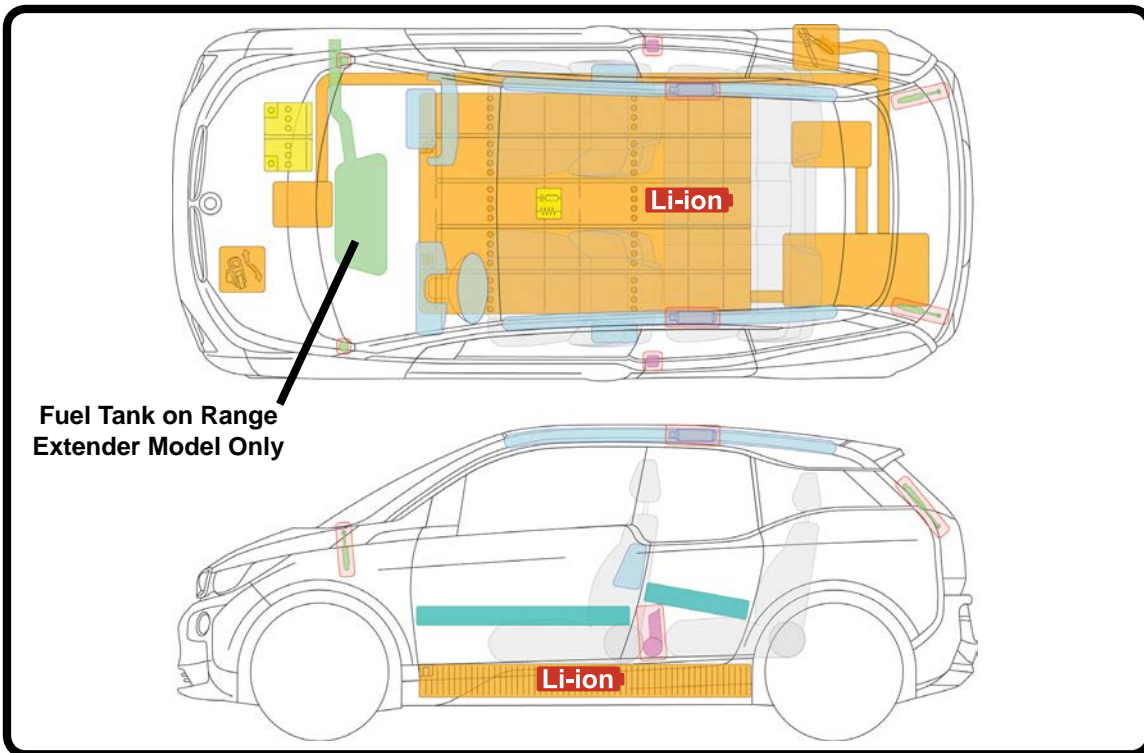

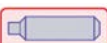

13

Li-ion (continued) **EXTRICATION INFORMATION**

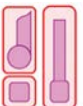
See pages 15, 22.



Fuel Tank on Range Extender Model Only

LEGEND		
 Airbag	 Bodywork Reinforcements	 SRS Control Unit
 Stored Gas Inflator	 Support Cylinder for Hood	 12V Battery
 Seatbelt Tensioner or Pretensioner	 Fuel Tank	 High-Voltage Power Cable
 High-Voltage Battery	 Emergency Disconnect (Cut Cable)	 Emergency Disconnect (Remove Plug)

SPECIAL CONCERNS

RANGE EXTENDER OPTION

Some models come with a range extender option that includes a gasoline generator and fuel storage. These models are considered extended range electric vehicles. Range extenders are located to the right of the HV disconnect.

For towing and post-incident instructions, see the **POST-INCIDENT** section on page 20.



2014-15



BMW

VEHICLE INFORMATION

Li-ion

See pages 15, 22.

IMMOBILIZE VEHICLE

- 1. **Chock the wheels.**
- 2. **Set parking brake.**
(pull the "P" switch, center console)
- 3. **Place vehicle into park.**
(push-button on top of gear lever, steering column)

DISABLE VEHICLE

Determine if vehicle is ON by presence of active display on tachometer.

PRIMARY PROCEDURE

- 1. If ON, turn the vehicle's ignition off by pressing the Start/Stop button.
- 2. Remove proximity key and keep it at least 16 feet from the vehicle.
- 3. Disconnect the 12V battery negative cable (underneath cover in engine compartment, driver's side).
- 4. Access the HV disconnect (underneath cover in engine compartment, driver's side) and unlock the connector for the HV emergency separation point (1). Pull apart in direction of arrow.

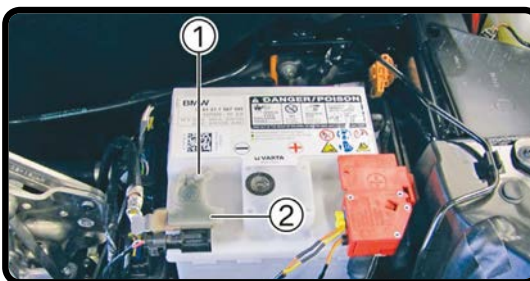

12V Battery Disconnect

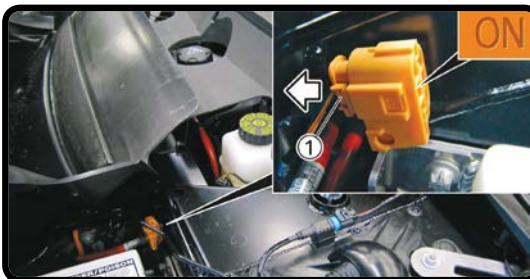

HV Disconnect

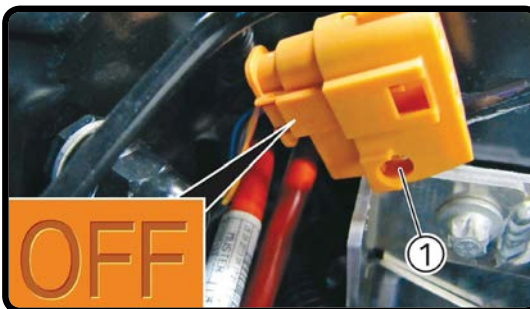

HV Disconnect in OFF Position

WARNINGS



NEVER cut, breach, or touch high voltage components or cabling (orange coating). Doing so could result in serious injury or death.



Lack of engine noise does not mean vehicle is OFF. Silent movement capability exists until vehicle is fully shut down.

BMW

BMW

PHEV



2014-15







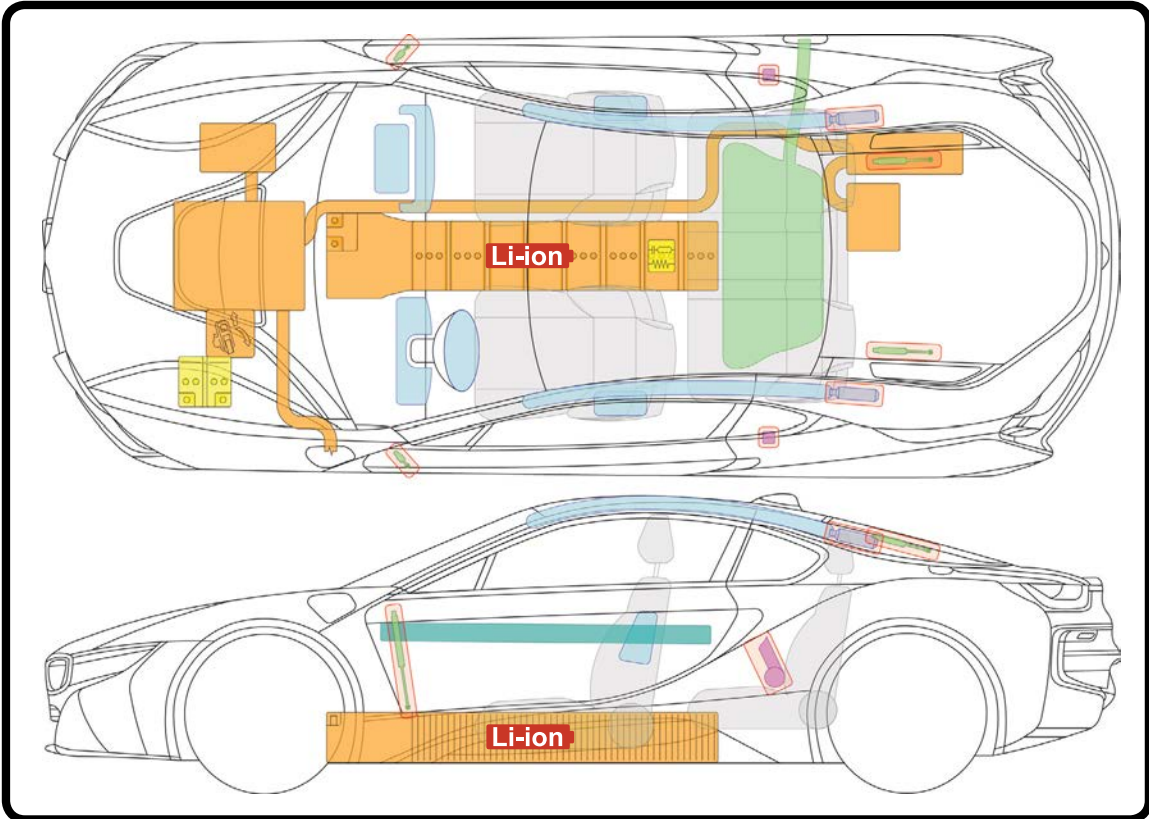

e Drive

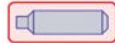

Li-ion (continued) **EXTRICATION INFORMATION**

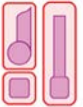
See pages 15, 22.



LEGEND		
 Airbag	 Bodywork Reinforcements	 SRS Control Unit
 Stored Gas Inflator	 Support Cylinder for Hood	 12V Battery
 Seatbelt Tensioner or Pretensioner	 Fuel Tank	 High-Voltage Power Cable
 High-Voltage Battery	 Emergency Disconnect (Remove Plug)	

For towing and post-incident instructions, see the **POST-INCIDENT** section on page 20.

118

BMW

BMW



2015-18



BMW

VEHICLE INFORMATION

Li-ion

See pages 15, 22.

IMMOBILIZE VEHICLE

1. **Chock the wheels.**
2. **Set parking brake.**
(pull the "P" switch, center console)
3. **Place vehicle into park.**
(push-button on top of gear selector, center console)

DISABLE VEHICLE

Determine if vehicle is ON by presence of active display on tachometer.

PRIMARY PROCEDURE

1. If ON, turn the vehicle's ignition off by pressing the Start/Stop button.
2. Remove proximity key and keep it at least 16 feet from the vehicle.
3. Disconnect the 12V battery negative cable (engine compartment, driver's side).
4. Access the HV disconnect (engine compartment, driver's side) and (1) unlock the connector (red). (2) Pull apart in the direction of the arrow. The HV system is deactivated when the hole is clear all the way through. The plug and connector cannot be completely separated.



12V Battery Disconnect



HV Disconnect

ALTERNATE PROCEDURE

1. Cut the second high voltage disconnect (under cover in luggage compartment).
2. Disconnect the 12V battery negative cable (engine compartment, driver's side).



Alternate HV Disconnect Cutting Solution

WARNINGS



NEVER cut, breach, or touch high voltage components or cabling (orange coating). Doing so could result in serious injury or death.



Lack of engine noise does not mean vehicle is OFF. Silent movement capability exists until vehicle is fully shut down.

BMW

BMW

PHEV











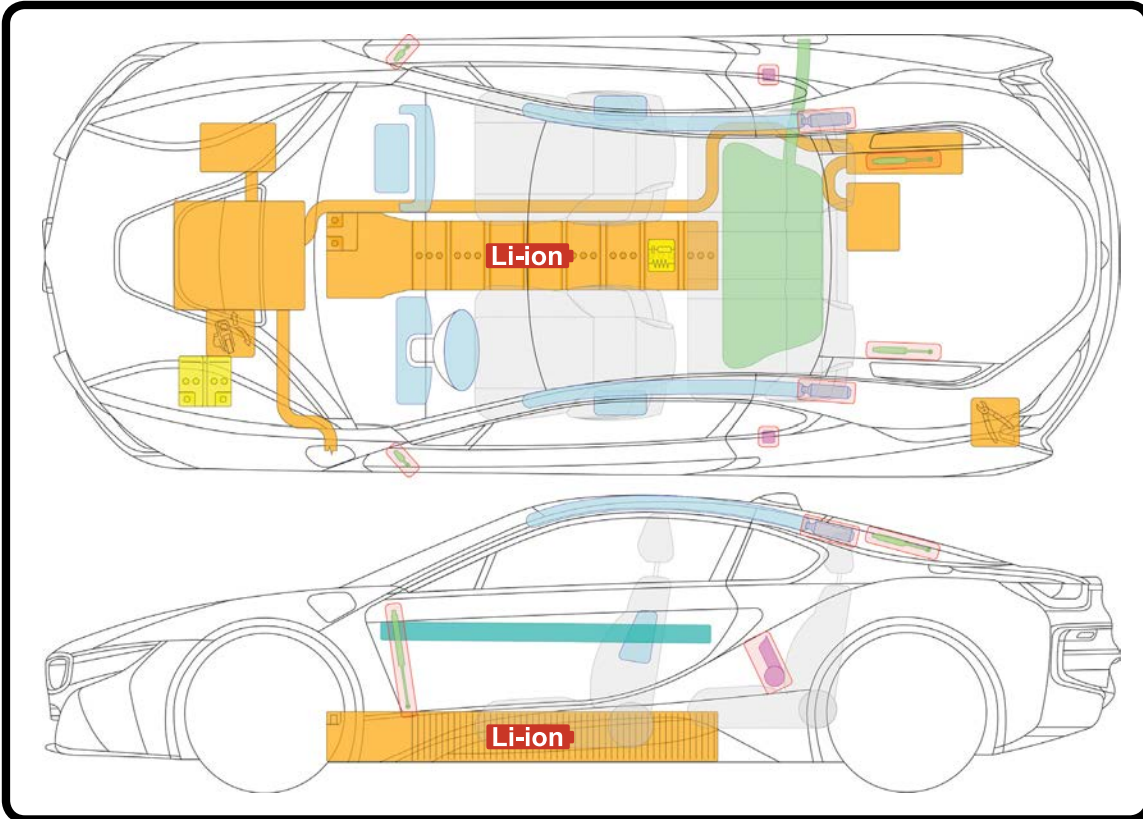



2015-18

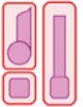

Li-ion (continued) **EXTRICATION INFORMATION**

See pages 15, 22.



LEGEND		
 Airbag	 Bodywork Reinforcements	 SRS Control Unit
 Stored Gas Inflator	 Support Cylinder for Hood	 12V Battery
 Seatbelt Tensioner or Pretensioner	 Fuel Tank	 High-Voltage Power Cable
 High-Voltage Battery	 Emergency Disconnect (Cut Cable)	 Emergency Disconnect (Remove Plug)

For towing and post-incident instructions, see the **POST-INCIDENT** section on page 20.



2015-18



BMW

BMW

X5

VEHICLE INFORMATION

Li-ion

See pages 15, 22.

IMMOBILIZE VEHICLE

1. **Chock the wheels.**
2. **Set parking brake.**
(pull the "P" switch, center console)
3. **Place vehicle into park.**
(push-button on top of gear lever, steering column)

DISABLE VEHICLE

Determine if vehicle is ON by presence of READY indicator near the tachometer.

PRIMARY PROCEDURE

1. If ON, turn the vehicle's ignition off by pressing the Start/Stop button.
2. Remove proximity key and keep it at least 16 feet from the vehicle.
3. Disconnect the 12V negative terminals on both the primary and auxiliary batteries (underneath cover in the luggage compartment).
4. Disconnect (1) connector lock (red) and (2) pull apart high voltage connection (behind right side trim panel in trunk).
5. Access the HV disconnect (underneath luggage cover in trunk) and unlock the connector for the HV emergency separation point (3). Pull apart in direction of arrow.

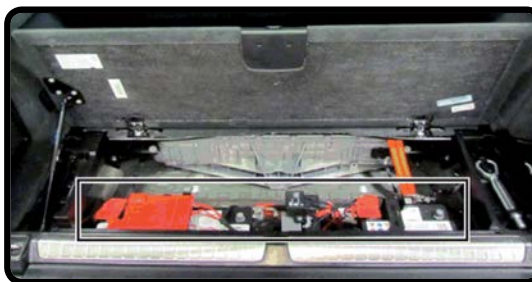

12V Battery Disconnect

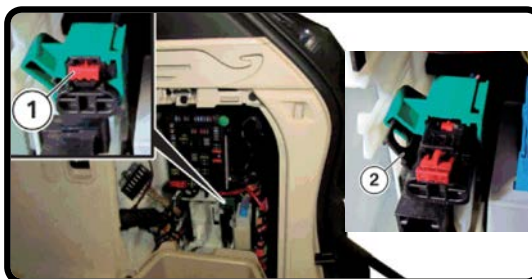

HV Connector Lock



HV Disconnect in Trunk



High Voltage Disconnect Under Hood

ALTERNATE PROCEDURE

(if trunk is not accessible)

1. Cut the high voltage disconnect loop (engine compartment, passenger's side).

NOTE: If the connector lock and 12v batteries in trunk are not accessible. Step 1 will result in the HV system being shut down but may not disable airbag system.

WARNINGS



NEVER cut, breach, or touch high voltage components or cabling (orange coating). Doing so could result in serious injury or death.



Lack of engine noise does not mean vehicle is OFF. Silent movement capability exists until vehicle is fully shut down.

PHEV



2015-18



X5

Li-ion (continued) **EXTRICATION INFORMATION**

See pages 15, 22.

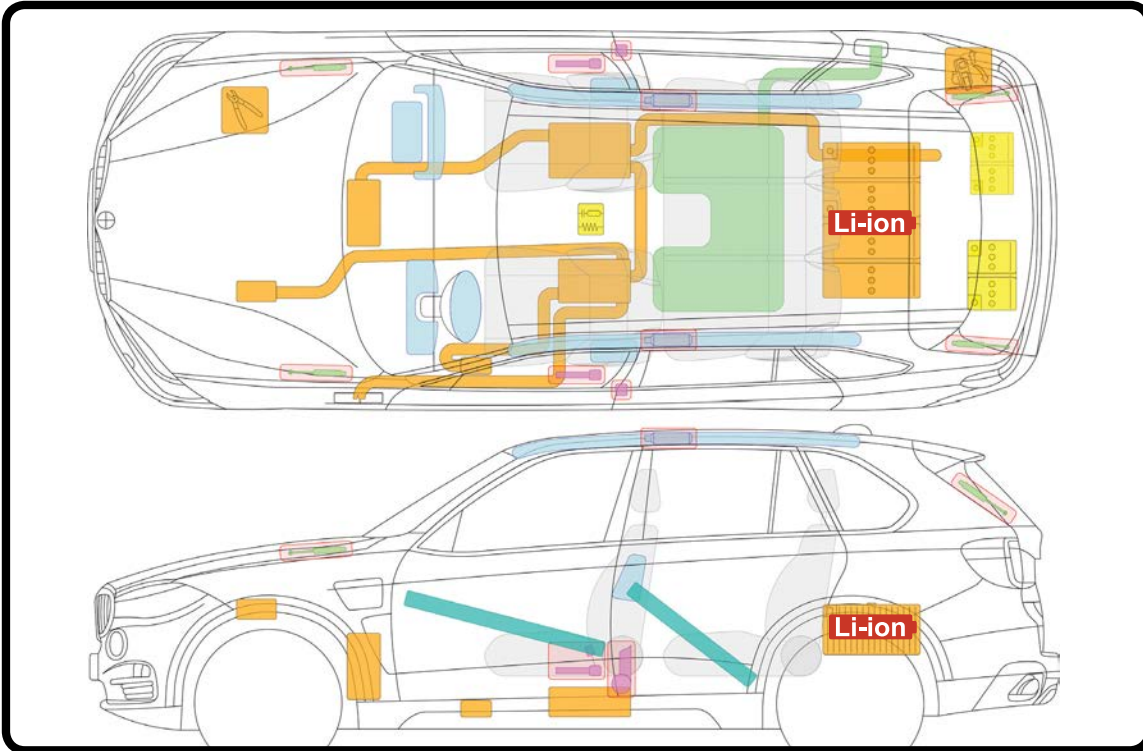

LEGEND		
Airbag	Bodywork Reinforcements	SRS Control Unit
Stored Gas Inflator	Support Cylinder for Hood	12V Battery
Seatbelt Tensioner or Pretensioner	Fuel Tank	High-Voltage Power Cable
High-Voltage Battery	Emergency Disconnect (Cut Cable)	Emergency Disconnect (Remove Plug)

A PLUGGED IN VEHICLE

If the vehicle is plugged in for charging, you should first unplug it. If access to unplug the vehicle is unavailable, “remove charge power” from the vehicle (done by turning off the power to the charge station).

For towing and post-incident instructions, see the **POST-INCIDENT** section on page 20.



Vehicle Charging Plug

BMW

BMW



2010-11



Active Hybrid

VEHICLE INFORMATION

Li-ion
See pages 15, 22.

IMMOBILIZE VEHICLE

- 1. **Chock the wheels.**
- 2. **Set parking brake.**
(pull-up switch, center console)
- 3. **Place vehicle into park.**
(joystick, center console)

DISABLE VEHICLE

Determine if vehicle is ON by presence of READY indicator on the bottom left of tachometer.

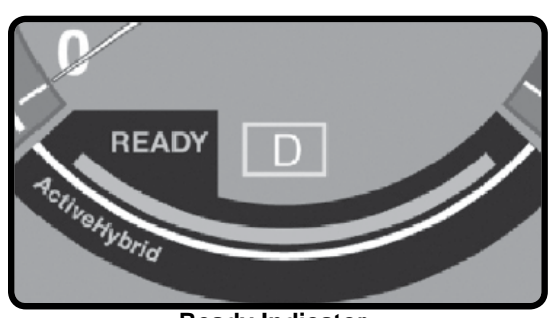

PRIMARY PROCEDURE

- 1. If ON, turn the vehicle's ignition off (push-button). Remove key.
- 2. Disconnect the 12V battery, negative terminal (in trunk). If there are two 12V batteries, disconnect both.



Ready Indicator

WARNINGS

-  NEVER cut, breach, or touch high voltage components or cabling. Doing so could result in serious injury or death.
-  Lack of engine noise does not mean vehicle is OFF. Silent movement or instant restart capability exists until vehicle is fully shut down.

BMW

BMW

X5

HEV



2010-11









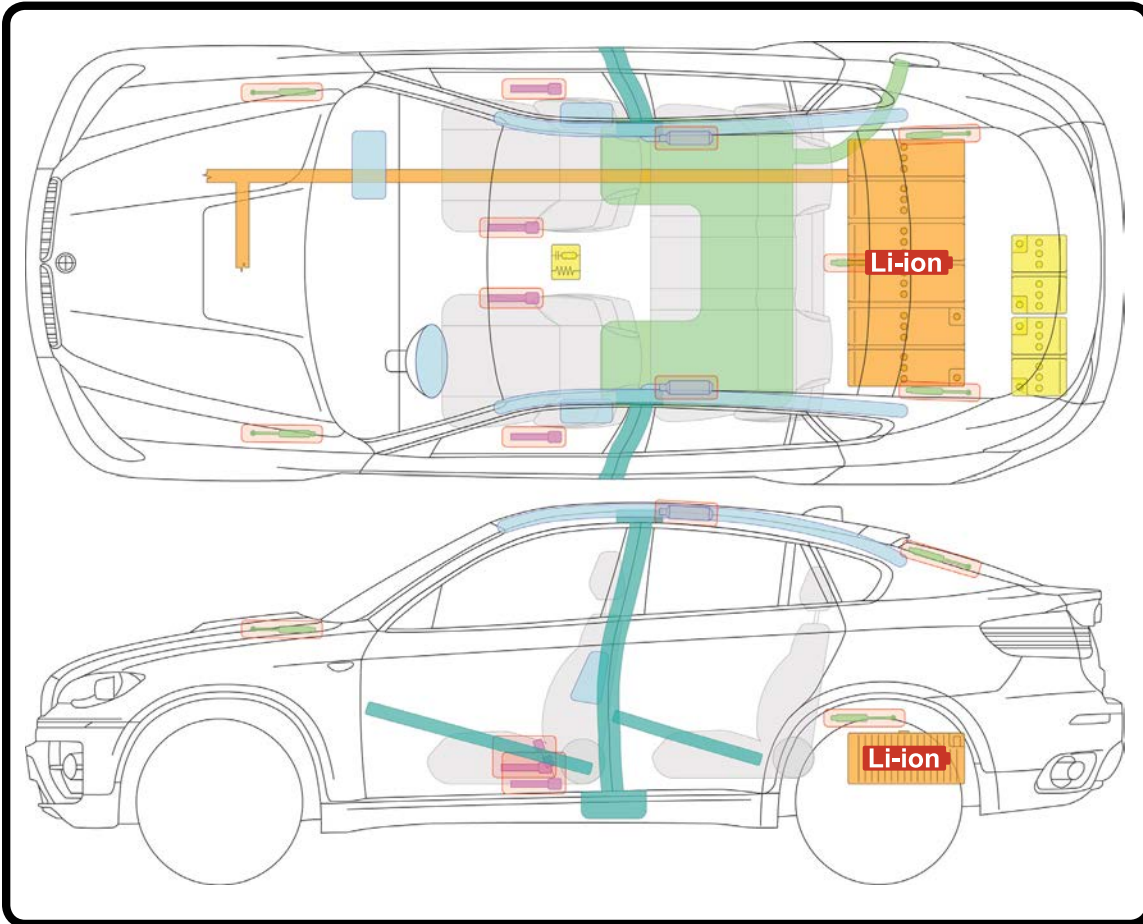

Active Hybrid

Li-ion (continued) **EXTRICATION INFORMATION**

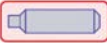
See pages 15, 22.

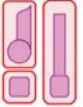

LEGEND

 Airbag	 Bodywork Reinforcements	 SRS Control Unit
 Stored Gas Inflator	 Support Cylinder for Hood	 12V Battery
 Seatbelt Tensioner or Pretensioner	 Fuel Tank	 High-Voltage Power Cable
 High-Voltage Battery		

For towing and post-incident instructions, see the **POST-INCIDENT** section on page 20.

X6

BMW

BMW



2012-16



BUICK
LaCROSSE
with eAssist

VEHICLE INFORMATION

IMMOBILIZE VEHICLE

1. **Chock the wheels.**
2. **Set parking brake.**
(push/pull switch, center console)
3. **Place vehicle into park.**
(gear selector, center console)

DISABLE VEHICLE

Determine if vehicle is ON.

- Vehicle is ON if tachometer needle points to AUTO STOP.
- Vehicle is OFF if needle points to OFF.

PRIMARY PROCEDURE

1. If ON, turn off ignition (steering column key or START/STOP button right of steering column).
2. Remove proximity key (if equipped) and keep it at least 16 feet (5 meters) from vehicle.
3. Cut black 12V battery cable at yellow cut tape (engine compartment).
4. Cut auxiliary power module cable at yellow cut tape (engine compartment).







Yellow Cut Tape Labels

NOTE: To avoid accidental reconnection of cable, remove a section of each.

ALTERNATE PROCEDURE

No alternate procedure is given. However, either step 1 by itself, or steps 3 and 4 combined, should disable both the SRS and HV systems (in the event either the ignition or the engine compartment cut points are not accessible).

WARNINGS

-  NEVER cut, breach, or touch high voltage components or cabling. Doing so could result in serious injury or death.
-  The high voltage system may remain powered for up to 1 minute after the vehicle is shut off.
-  The SRS system (airbags, etc.) may remain powered for up to 1 minute after disabling.
-  Lack of engine noise does not mean vehicle is OFF. Silent movement or instant restart capability exists until vehicle is fully shut down.



2012-16









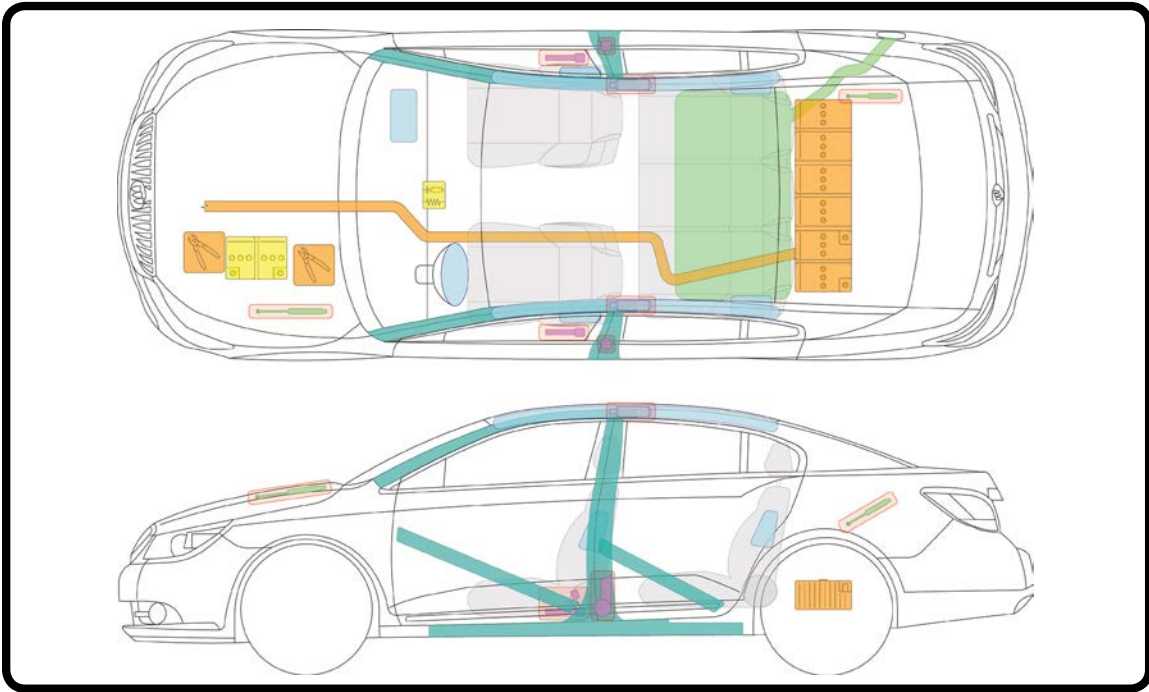

with eAssist

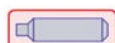
BUICK LaCROSSE

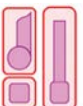
(continued) **EXTRICATION INFORMATION**



LEGEND		
 Airbag	 Bodywork Reinforcements	 SRS Control Unit
 Stored Gas Inflator	 Support Cylinder for Hood	 12V Battery
 Seatbelt Tensioner or Pretensioner	 Fuel Tank	 High-Voltage Power Cable
 High-Voltage Battery	 Emergency Disconnect (Cut Cable)	

SRS SYSTEM

- The LaCrosse is equipped with six standard airbags to protect the occupant in front, side and rollover crashes. There are two optional thorax airbags located within the rear seat back.
- There are also dual pretensioner seat belts that work together with the airbag system.
- This vehicle may be equipped with dual-stage airbags and the appearance of deployed airbags does NOT ensure all stages of the airbags have deployed.

For towing and post-incident instructions, see the **POST-INCIDENT** section on page 20.



2018-19



VEHICLE INFORMATION

Li-ion

See pages 15, 22.

IMMOBILIZE VEHICLE

1. **Chock the wheels.**
2. **Set parking brake.**
(push/pull switch, center console)
3. **Place vehicle into park.**
(gear selector, center console)

DISABLE VEHICLE

Determine if vehicle is ON.

- Vehicle is ON if tachometer needle points to AUTO STOP.
- Vehicle is OFF if needle points to OFF.

PRIMARY PROCEDURE

1. If ON, turn off ignition (steering column key or START/STOP button right of steering column).
2. Remove proximity key (if equipped) and keep it at least 16 feet (5 meters) from vehicle.
3. Cut black 12V battery cable at yellow cut tape (engine compartment).

NOTE: To avoid accidental reconnection remove a section of cable.







Yellow Cut Tape Label

ALTERNATE PROCEDURE

No alternate procedure is given. However, either step 1 or step 3, should disable both the SRS and HV systems (in the event either the ignition or the engine compartment cut points are not accessible).

WARNINGS

-  NEVER cut, breach, or touch high voltage components or cabling. Doing so could result in serious injury or death.
-  The high voltage system may remain powered for up to 1 minute after the vehicle is shut off.
-  The SRS system (airbags, etc.) may remain powered for up to 1 minute after disabling.
-  Lack of engine noise does not mean vehicle is OFF. Silent movement or instant restart capability exists until vehicle is fully shut down.

BUICK
LaCROSSE
with eAssist

BUICK



2018-19









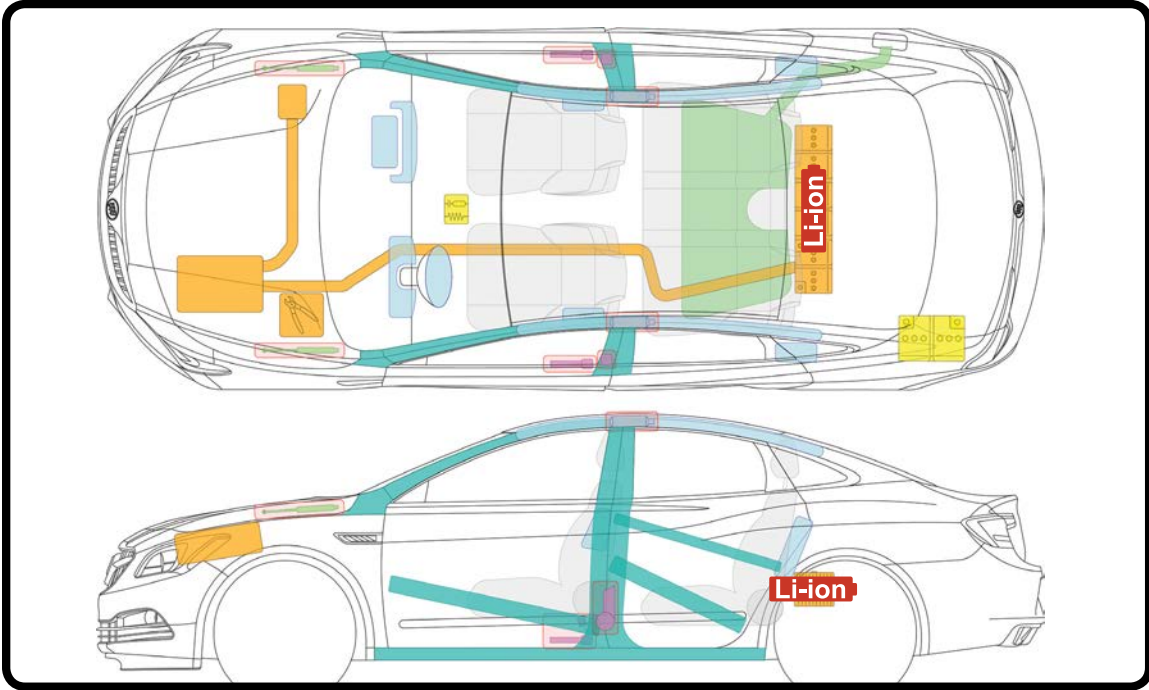

with eAssist

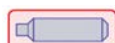
Li-ion (continued) **EXTRICATION INFORMATION**

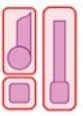
See pages 15, 22.



LEGEND		
 Airbag	 Bodywork Reinforcements	 SRS Control Unit
 Stored Gas Inflator	 Support Cylinder for Hood	 12V Battery
 Seatbelt Tensioner or Pretensioner	 Fuel Tank	 High-Voltage Power Cable
 High-Voltage Battery	 Emergency Disconnect (Cut Cable)	

SRS SYSTEM

- The LaCrosse is equipped with six standard airbags to protect the occupant in front, side and rollover crashes. There are two optional thorax airbags located within the rear seat back.
- There are also dual pretensioner seat belts that work together with the airbag system.
- This vehicle may be equipped with dual-stage airbags and the appearance of deployed airbags does NOT ensure all stages of the airbags have deployed.

For towing and post-incident instructions, see the **POST-INCIDENT** section on page 20.

BUICK **LaCROSSE**



2012-16



BUICK

REGAL

BUICK

with eAssist

VEHICLE INFORMATION

IMMOBILIZE VEHICLE

1. **Chock the wheels.**
2. **Set parking brake.**
(push/pull switch, center console)
3. **Place vehicle into park.**
(gear selector, center console)

DISABLE VEHICLE

Determine if vehicle is ON.

- Vehicle is OFF if needle points to OFF.

PRIMARY PROCEDURE

1. If ON, turn off ignition (steering column key or START/STOP button right of steering column).
2. Remove proximity key (if equipped) and keep it at least 16 feet (5 meters) from vehicle.
3. Cut black 12V battery cable at yellow cut tape (engine compartment).
4. Cut auxiliary power module cable at yellow cut tape (engine compartment).







Yellow Cut Tape Labels

NOTE: To avoid accidental reconnection of cable, remove a section of each.

ALTERNATE PROCEDURE

No alternate procedure is given. However, either step 1 by itself, or steps 3 and 4 combined, should disable both the SRS and HV systems (in the event either the ignition or the engine compartment cut points are not accessible).

WARNINGS

-  NEVER cut, breach, or touch high voltage components or cabling. Doing so could result in serious injury or death.
-  The high voltage system may remain powered for up to 1 minute after the vehicle is shut off.
-  The SRS system (airbags, etc.) may remain powered for up to 1 minute after disabling.
-  Lack of engine noise does not mean vehicle is OFF. Silent movement or instant restart capability exists until vehicle is fully shut down.

HEV



2012-16











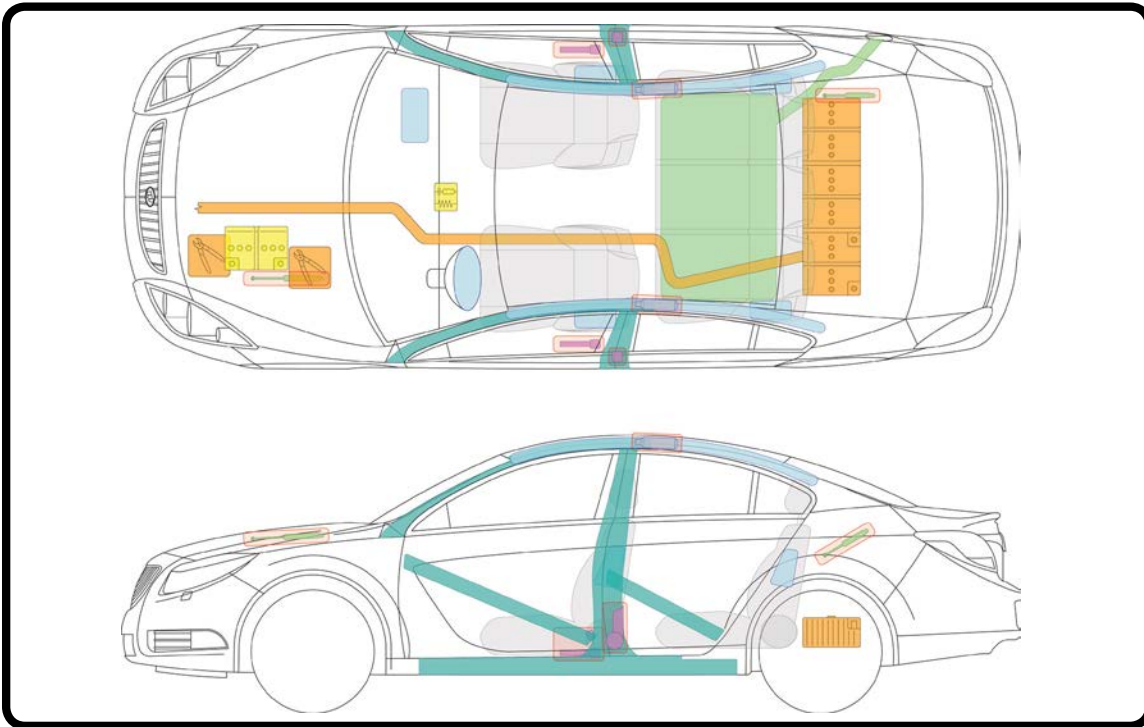

with eAssist

REGAL

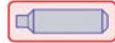
BUICK

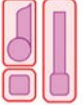
(continued) **EXTRICATION INFORMATION**



LEGEND		
 Airbag	 Bodywork Reinforcements	 SRS Control Unit
 Stored Gas Inflator	 Support Cylinder for Hood	 12V Battery
 Seatbelt Tensioner or Pretensioner	 Fuel Tank	 High-Voltage Power Cable
 High-Voltage Battery	 Emergency Disconnect (Cut Cable)	

SRS SYSTEM

- The Regal is equipped with six standard airbags to protect the occupant in front, side, and rollover crashes.
- There are also dual pretensioner seat belts that work together with the airbag system.
- This vehicle may be equipped with dual-stage airbags and the appearance of deployed airbags does NOT ensure all stages of the airbags have deployed.

For towing and post-incident instructions, see the **POST-INCIDENT** section on page 20.



2017-18



VEHICLE INFORMATION

Li-ion

See pages 15, 22.

IMMOBILIZE VEHICLE

1. **Chock the wheels.**
2. **Set parking brake.**
(electric parking brake switch, left-side console)
3. **Place vehicle into park.**
(gear selector, center console)





DISABLE VEHICLE

Determine if vehicle is ON by illumination of the instrument displays.

PRIMARY PROCEDURE

1. If ON, turn off ignition (power button, center instrument panel).
2. Remove proximity key and keep it at least 16 feet from the vehicle.
3. Cut the 12V positive battery cable identified by the yellow First Responder tag. (behind the right rear closeout panel in the trunk).

WARNINGS

-  NEVER cut, breach, or touch orange high voltage components or cabling. Doing so could result in serious injury or death.
-  The high voltage system may remain powered for up to 1 minute after the vehicle is shut off.
-  The SRS system (airbags, etc.) may remain powered for up to 10 seconds after disabling.
-  Lack of engine noise does not mean vehicle is OFF. Silent movement or instant restart capability exists until vehicle is fully shut down.

Cadillac

CTS

CADILLAC

PHEV



2017-18



PLUG IN HYBRID

CT6

Li-ion (continued) **EXTRICATION INFORMATION**

See pages 15, 22.

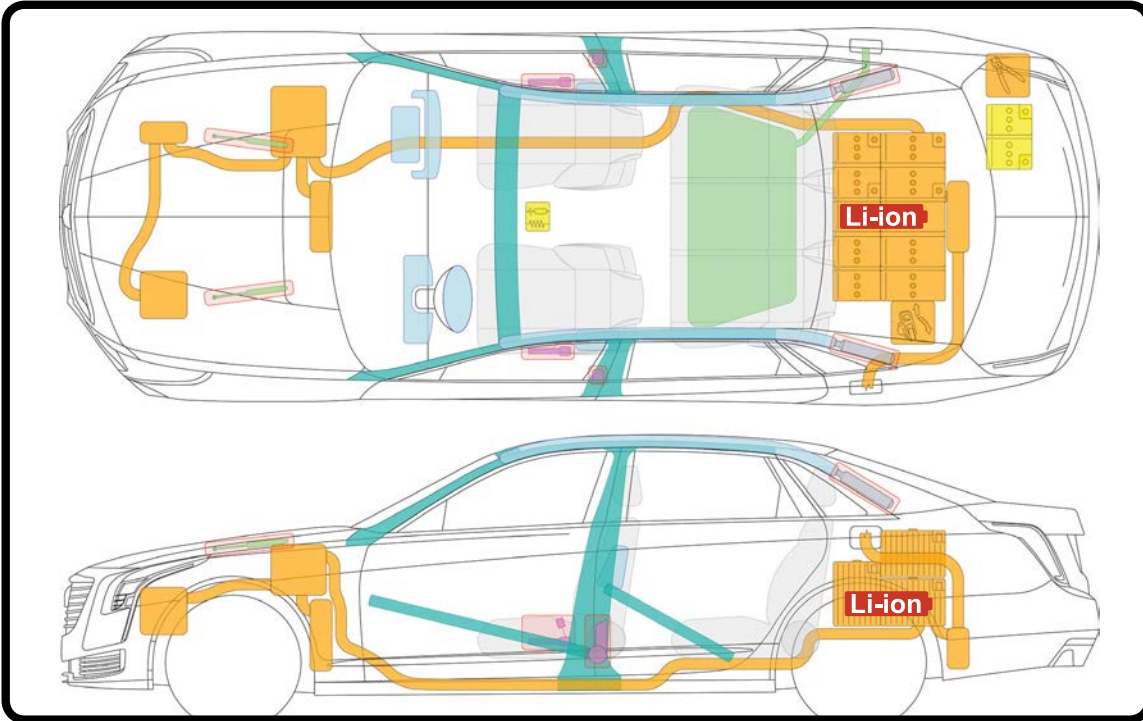

LEGEND			
	Airbag		Bodywork Reinforcements
	Stored Gas Inflator		Support Cylinder for Hood
	Seatbelt Tensioner or Pretensioner		Fuel Tank
	High-Voltage Battery		Emergency Disconnect (Cut Cable)
	SRS Control Unit		High-Voltage Power Cable
	12V Battery		Emergency Disconnect (Remove Plug)

SPECIAL CONCERNS

A PLUGGED IN VEHICLE

If the vehicle is plugged in for charging, you should first unplug it. If access to unplug the vehicle is unavailable, “remove charge power” from the vehicle (done by turning off the power to the charge station).



Vehicle Charging Plug

For towing and post-incident instructions, see the **POST-INCIDENT** section on page 20.

CADILLAC

Cadillac



2014-16



Cadillac

VEHICLE INFORMATION

Li-ion

See pages 15, 22.

IMMOBILIZE VEHICLE

1. **Chock the wheels.**
2. **Set parking brake.**
(electric parking brake switch, left-side console)
3. **Place vehicle into park.**
(gear selector, center console)

DISABLE VEHICLE

Determine if vehicle is ON.

- Vehicle is ON if an active battery or fuel gauge is displayed.



Active Battery and Fuel Gauge

PRIMARY PROCEDURE

1. If ON, turn off ignition (power button, center instrument panel).
2. Remove proximity key and keep it at least 16 feet from the vehicle.
3. Cut the 12V positive battery cable identified by the yellow First Responder tag. (behind the left rear closeout panel in the rear compartment of the vehicle).



Cut 12V Positive Battery Cable

ALTERNATE PROCEDURE

1. Cut the 12V positive battery cable identified by the yellow First Responder tag. (behind the left rear closeout panel in the rear compartment of the vehicle).
2. Remove the Manual Service Disconnect (located underneath center console box).

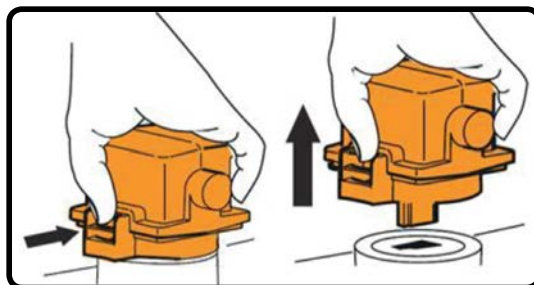

Manual Service Disconnect

HIGH VOLTAGE MANUAL DISCONNECT

You can minimize the potential for high voltage current flow by removing the Manual Service Disconnect (located underneath center console box).

WARNINGS

- NEVER cut, breach, or touch orange high voltage components or cabling. Doing so could result in serious injury or death.
- The high voltage system may remain powered for up to 1 minute after the vehicle is shut off.
- The SRS system (airbags, etc.) may remain powered for up to 1 minute after disabling.
- Lack of engine noise does not mean vehicle is OFF. Silent movement or instant restart capability exists until vehicle is fully shut down.

ELR

CADILLAC



2014-16

ELR



ELR

Li-ion

See pages 15, 22.

(continued)

EXTRICATION INFORMATION

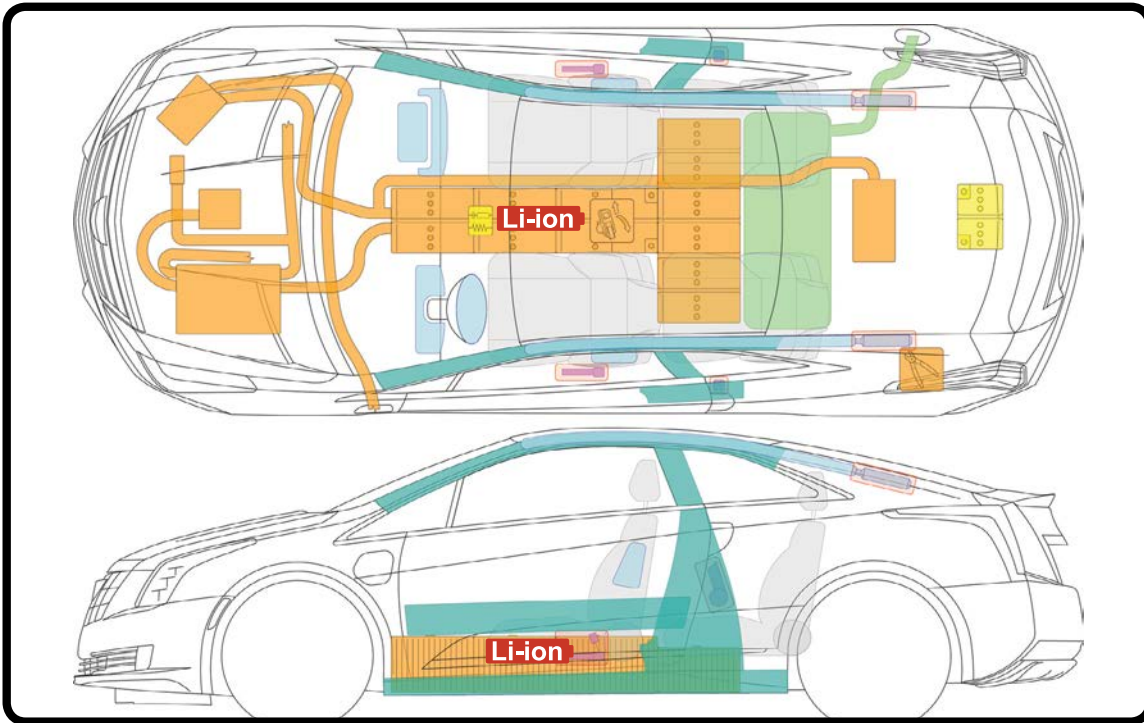

LEGEND			
	Airbag		Bodywork Reinforcements
	Stored Gas Inflator		Support Cylinder for Hood
	Seatbelt Tensioner or Pretensioner		Fuel Tank
	High-Voltage Battery		Emergency Disconnect (Cut Cable)
	SRS Control Unit		High-Voltage Power Cable
	12V Battery		Emergency Disconnect (Remove Plug)

SPECIAL CONCERNS

A PLUGGED IN VEHICLE

If the vehicle is plugged in for charging, you should first unplug it. If access to unplug the vehicle is unavailable, “remove charge power” from the vehicle (done by turning off the power to the charge station).



Vehicle Charging Plug

For towing and post-incident instructions, see the **POST-INCIDENT** section on page 20.



2008-13



VEHICLE INFORMATION

IMMOBILIZE VEHICLE

1. Chock the wheels.
2. Set parking brake.
3. Place vehicle into park. (steering column)

DISABLE VEHICLE

Determine if vehicle is ON.

- Vehicle is ON if tachometer needle points to AUTO STOP.
- Vehicle is OFF if needle points to OFF.

PRIMARY PROCEDURE

1. If ON, turn the vehicle's ignition off (steering column, key). Remove key.
2. Disconnect 12V positive (+) battery cable (engine compartment, driver's side). 12V battery has lever-type quick release terminals.
3. Ensure the terminal cannot contact the battery post.

ALTERNATE PROCEDURE

(if the ignition key is not accessible)

1. Disconnect the 12V positive (+) battery cable (engine compartment, driver's side).
2. Cut all three exposed 12V positive cables identified by the yellow First Responder labels.



Cut 3 Exposed Cables (Alternate Procedure)





HIGH VOLTAGE MANUAL DISCONNECT

If accessible, you can minimize potential for high voltage current flow by removing the manual disconnect lever from the high voltage battery. It is located under the passenger's side, second row, rear sub-floor.



300V Hybrid Battery Manual Disconnect

WARNINGS

-  NEVER cut, breach, or touch orange high voltage components or cabling. Doing so could result in serious injury or death.
-  The high voltage system may remain powered for up to 1 minute after the vehicle is shut off.
-  The SRS system (airbags, etc.) may remain powered for up to 1 minute after disabling.
-  Lack of engine noise does not mean vehicle is OFF. Silent movement or instant restart capability exists until vehicle is fully shut down.

Cadillac

ESCALADE

CADILLAC

HEV



2008-13

HYBRID



ESCALADE

(continued) **EXTRICATION INFORMATION**

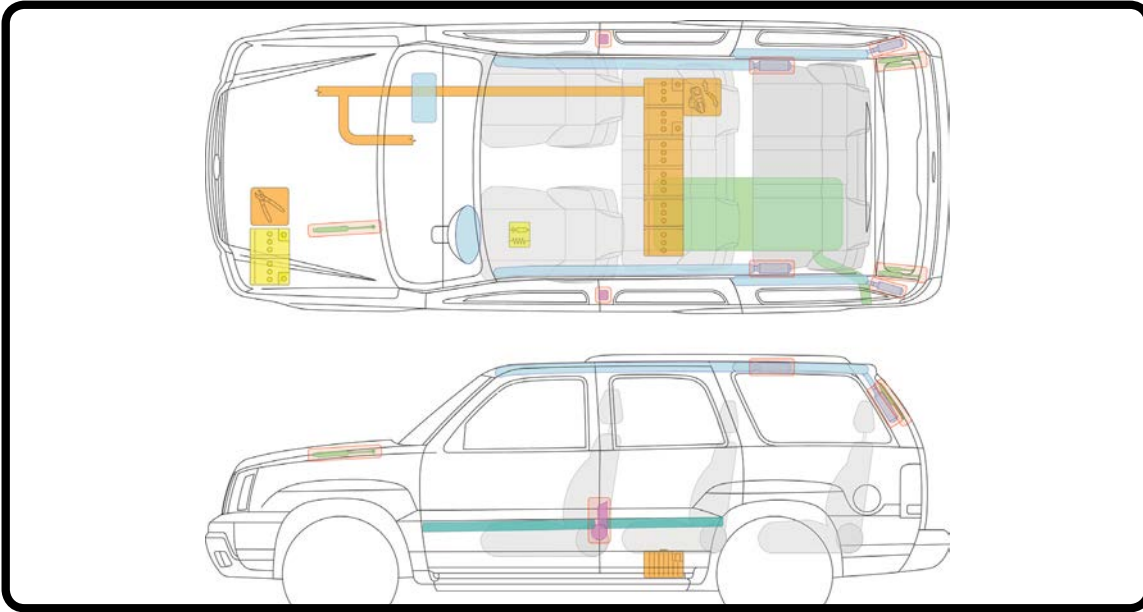

LEGEND		
Airbag	Bodywork Reinforcements	SRS Control Unit
Stored Gas Inflator	Support Cylinder for Hood	12V Battery
Seatbelt Tensioner or Pretensioner	Fuel Tank	High-Voltage Power Cable
High-Voltage Battery	Emergency Disconnect (Cut Cable)	Emergency Disconnect (Remove Plug)

REMOVING THE SERVICE DISCONNECT (DETAIL)



1. Pull Up

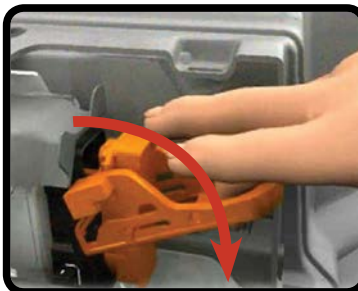

2. Pull Down

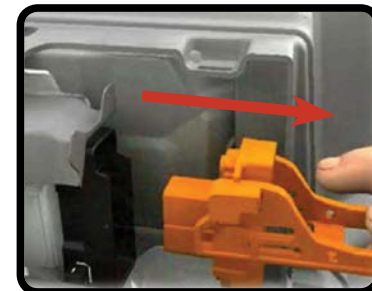

3. Pull Out

For towing and post-incident instructions, see the **POST-INCIDENT** section on page 20.

CADILLAC

Cadillac



2017-19



CHEVROLET

CHEVROLET

BOLT

VEHICLE INFORMATION

Li-ion

See pages 15, 22.

IMMOBILIZE VEHICLE

- 1. **Chock the wheels.**
- 2. **Set parking brake.**
(push/pull switch, center console)
- 3. **Place vehicle into park.**
(center console)





DISABLE VEHICLE

Determine if vehicle is ON by illumination of the instrument displays.

PRIMARY PROCEDURE

- 1. If ON, turn off ignition (push-button, center console).
- 2. Remove proximity key and keep it at least 16 feet from the vehicle.
- 3. Cut the low voltage cable at the yellow tag cut position (driver's side, engine compartment).

WARNINGS

-  NEVER cut, breach, or touch orange high voltage components or cabling. Doing so could result in serious injury or death.
-  The high voltage system may remain powered for up to 1 minute after the vehicle is shut off.
-  The SRS system (airbags, etc.) may remain powered for up to 10 seconds after disabling.
-  In the event of a fire involving a charging station, reference the **FIRE** portion of this guide, and treat it as an energized electrical fire until power to the charger can be shut down.
-  This vehicle does not have an internal combustion engine. Lack of engine noise does not mean vehicle is OFF. Silent movement capability exists until vehicle is fully shut down.



2017-19



Li-ion (continued) **EXTRICATION INFORMATION**

See pages 15, 22.

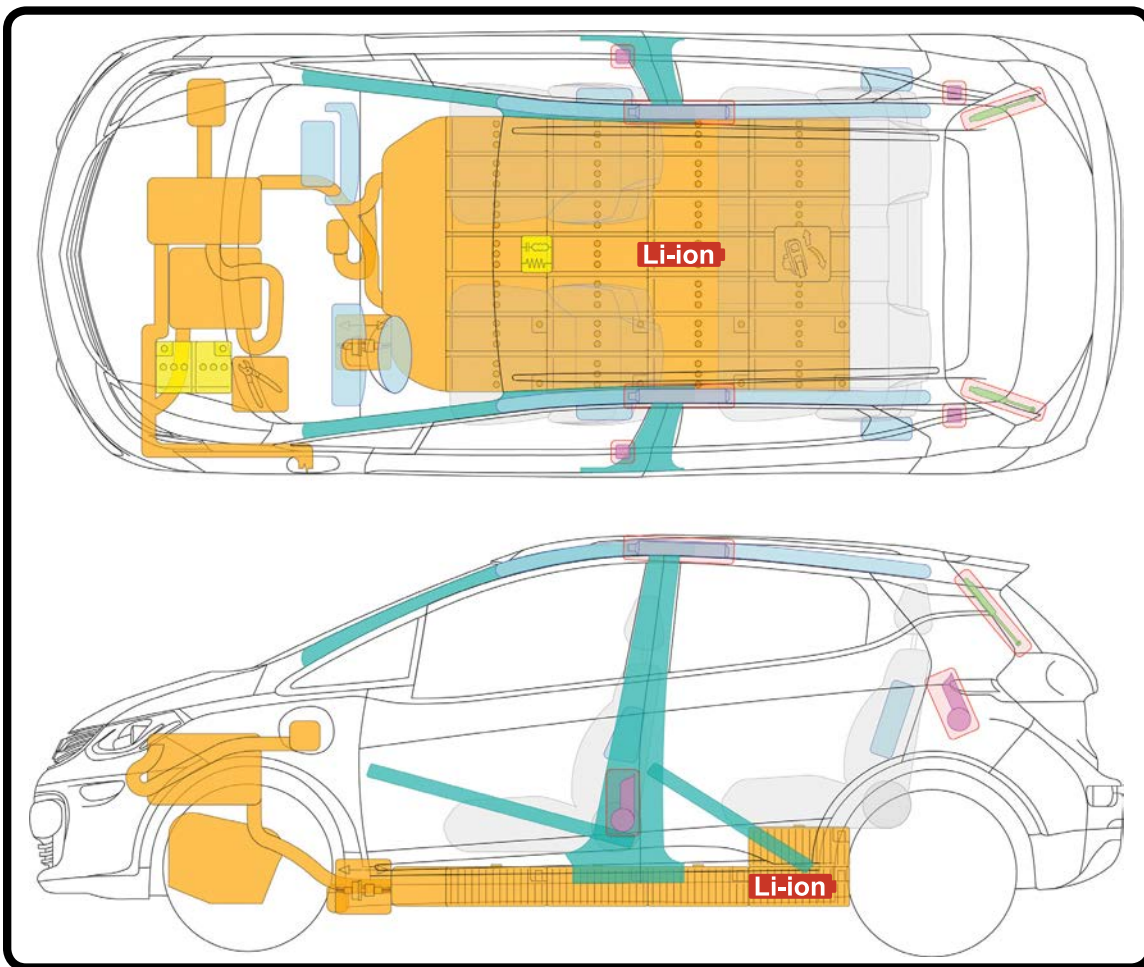

LEGEND		
Airbag	Bodywork Reinforcements	SRS Control Unit
Stored Gas Inflator	Support Cylinder for Hood	12V Battery
Seatbelt Tensioner or Pretensioner	Emergency Disconnect (Disconnect Plug)	High-Voltage Power Cable
High-Voltage Battery	Emergency Disconnect (Cut Cable)	Emergency Disconnect (Remove Plug)

For towing and post-incident instructions, see the **POST-INCIDENT** section on page 20.



2007-08



FUEL CELL

CHEVROLET

CHEVROLET

EQUINOX

VEHICLE INFORMATION



See page 24.

IMMOBILIZE VEHICLE

- 1. **Chock the wheels.**
- 2. **Set parking brake.** (hand brake, center console)
- 3. **Place vehicle into park.** (gear selector, center console)

DISABLE VEHICLE

PRIMARY PROCEDURE

- 1. Turn the ignition key to the OFF position.
- 2. Pull the hood release latch. This interrupts the normal Fuel Cell System shutdown procedure, disconnects the HV power supply, and stops hydrogen flow to the propulsion system.
- 3. Remove the 12V battery cover and disconnect or cut the 12V negative battery cable.

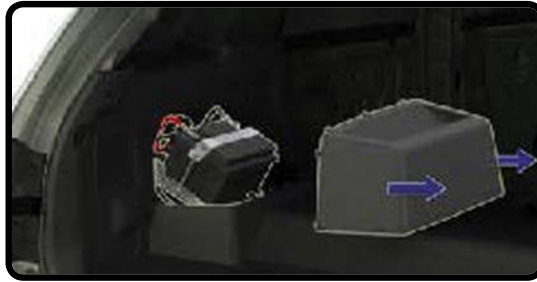

Disconnect the 12V Negative Cables



Pressure Relief Valve - Drivers Side View

SPECIAL CONCERNS

PRESSURE RELIEF VALVE (PRV)

PRVs are located underneath the rear driver's side of the vehicle. There is a PRV on each of the three hydrogen storage tanks. PRVs open when exposed to fire to vent hydrogen and prevent over-pressurization. A loud hissing noise is emitted from the rear during a hydrogen release. The tanks release hydrogen independently depending on their exposure to fire. Release by different tanks can be separated by several minutes. All of the tanks may not release if they are not similarly exposed to fire. A release of one tank may last several minutes. The venting hydrogen will disperse quickly. It will likely ignite and burn if a fire or ignition source is present.

NOTE: Hydrogen gas typically burns with a flame that is only visible at night.

WARNINGS

- NEVER cut, breach, or touch high voltage components or cabling. Doing so could result in serious injury or death.
- Do NOT cut the fuel lines, cutting fuel lines will release hydrogen in the fuel lines.
- The SRS system (airbags, etc.) may remain powered for up to 10 seconds after disabling.
- Fuel cell vehicles operate silently, lack of an engine noise does not mean the vehicle is OFF. Silent movement capability exists until vehicle is fully shut down.



2007-08



H
See page 24.

(continued) **EXTRICATION INFORMATION**

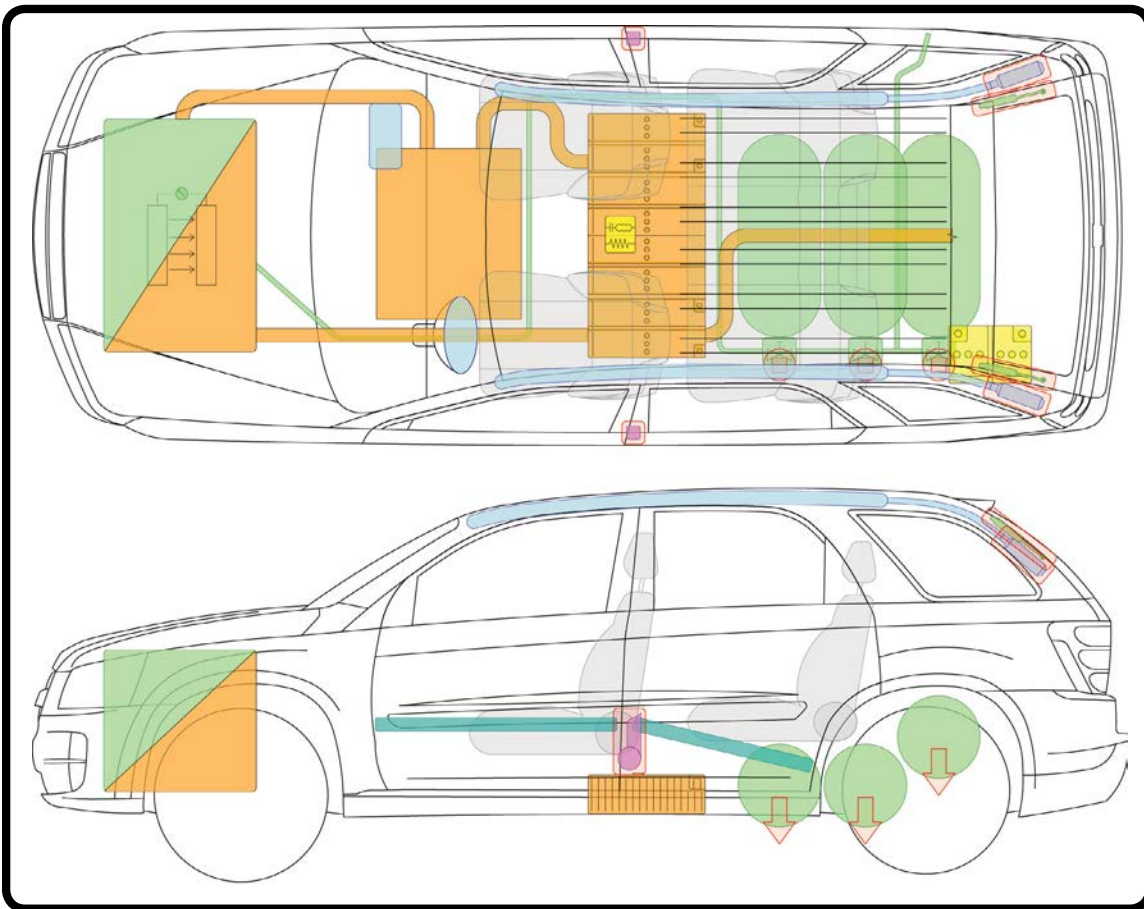

LEGEND		
	Airbag	
	Stored Gas Inflator	
	Seatbelt Tensioner or Pretensioner	
	High-Voltage Battery	
	Bodywork Reinforcements	
	Pressure Relief Valve	

For towing and post-incident instructions, see the **POST-INCIDENT** section on page 20.



2011-19



CHEVROLET

**MANUAL
CNG
SHUT-OFF**

CNG ONLY
Service Pressure
20,000/175 (2,000/175) PSI



VEHICLE INFORMATION

CNG
See page 25.

IMMOBILIZE VEHICLE

- 1. Chock the wheels.
- 2. Set parking brake. (foot pedal)
- 3. Place vehicle into park. (steering column)

DISABLE VEHICLE

PRIMARY PROCEDURE

- 1. Turn the ignition key to the OFF position.
- 2. Disconnect both 12V battery cables (engine compartment, passenger's side).
- 3. Turn the isolation valve, 1/4 turn to the OFF position (under the vehicle, midway between the front and rear tires on the inside of the driver's side frame).



Disconnect the 12V Battery Cables

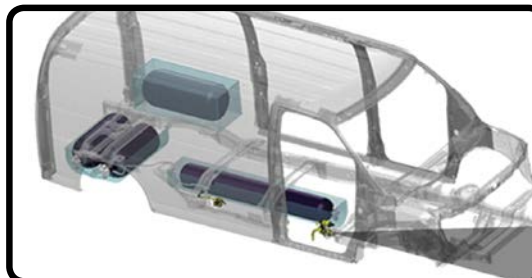

Isolation Valve Location

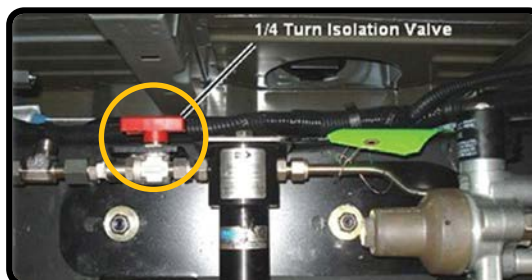

Turn Isolation Valve 1/4 Turn

WARNINGS

- Do NOT cut the fuel lines, cutting fuel lines will release the natural gas in the fuel lines.
- Do NOT try to stop a leak by over-tightening any fitting or isolation valve.
- The SRS system (airbags, etc.) may remain powered for up to 1 minute after disabling.
- Natural gas becomes flammable at concentrations between 5% and 15% in air.

CHEVROLET EXPRESS



2011-19



CHEVROLET EXPRESS

CHEVROLET EXPRESS





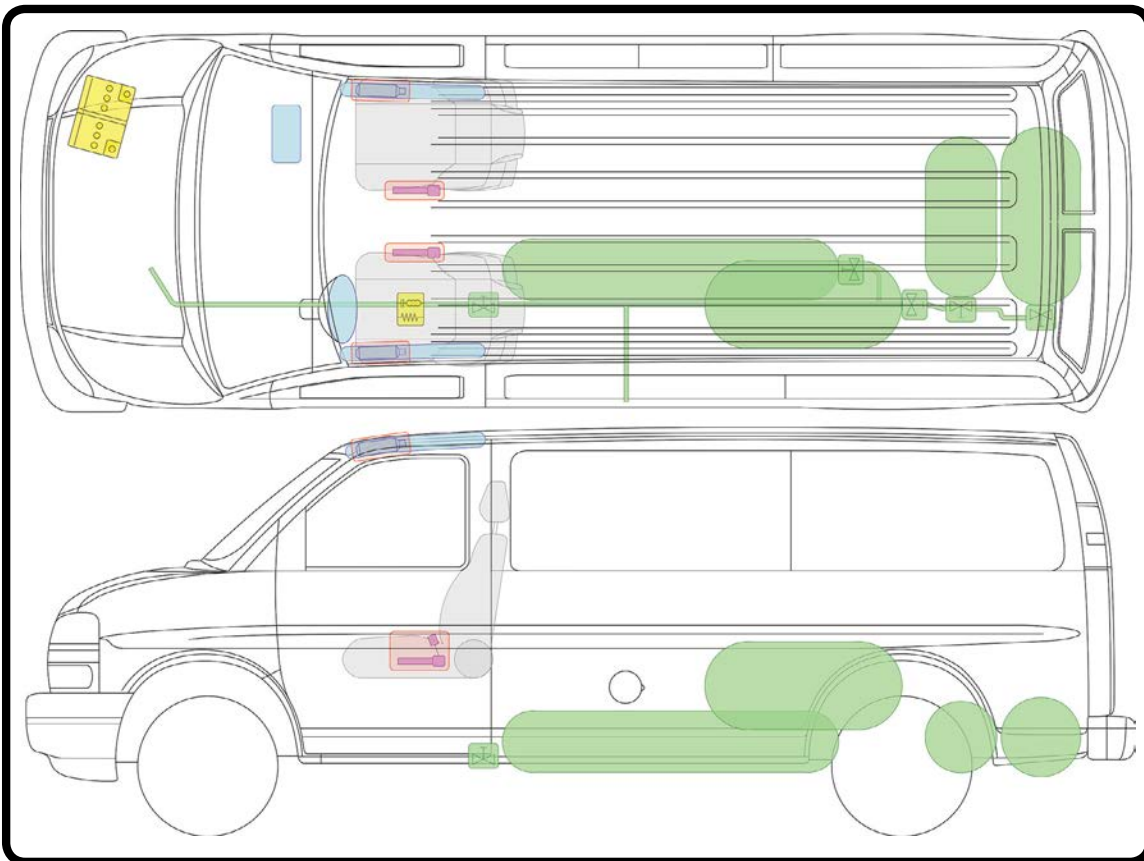

 See page 25.

(continued)

EXTRICATION INFORMATION

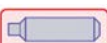

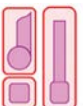
LEGEND

 Airbag		 SRS Control Unit
 Stored Gas Inflator		 12V Battery
 Seatbelt Tensioner or Pretensioner	 Fuel Tank	 Pressure Relief Valve

For towing and post-incident instructions, see the **POST-INCIDENT** section on page 20.



2011-19



CHEVROLET

VEHICLE INFORMATION



IMMOBILIZE VEHICLE

- 1. **Chock the wheels.**
- 2. **Set parking brake.** (foot pedal)
- 3. **Place vehicle into park.** (steering column)

DISABLE VEHICLE

PRIMARY PROCEDURE

- 1. Turn the ignition key to the OFF position.
- 2. Disconnect both 12V battery cables (engine compartment, passenger's side).



Disconnect the 12V Battery Cables

WARNINGS

- Do NOT cut the fuel lines, cutting fuel lines will release the propane gas in the fuel lines.
- Do NOT try to stop a leak by over-tightening any fitting or isolation valve.
- The SRS system (airbags, etc.) may remain powered for up to 1 minute after disabling.
- Propane gas becomes flammable at concentrations between 2.15% and 9.7% in air.

CHEVROLET

EXPRESS

LPG

CHEVROLET



2011-19



(continued)

EXTRICATION INFORMATION

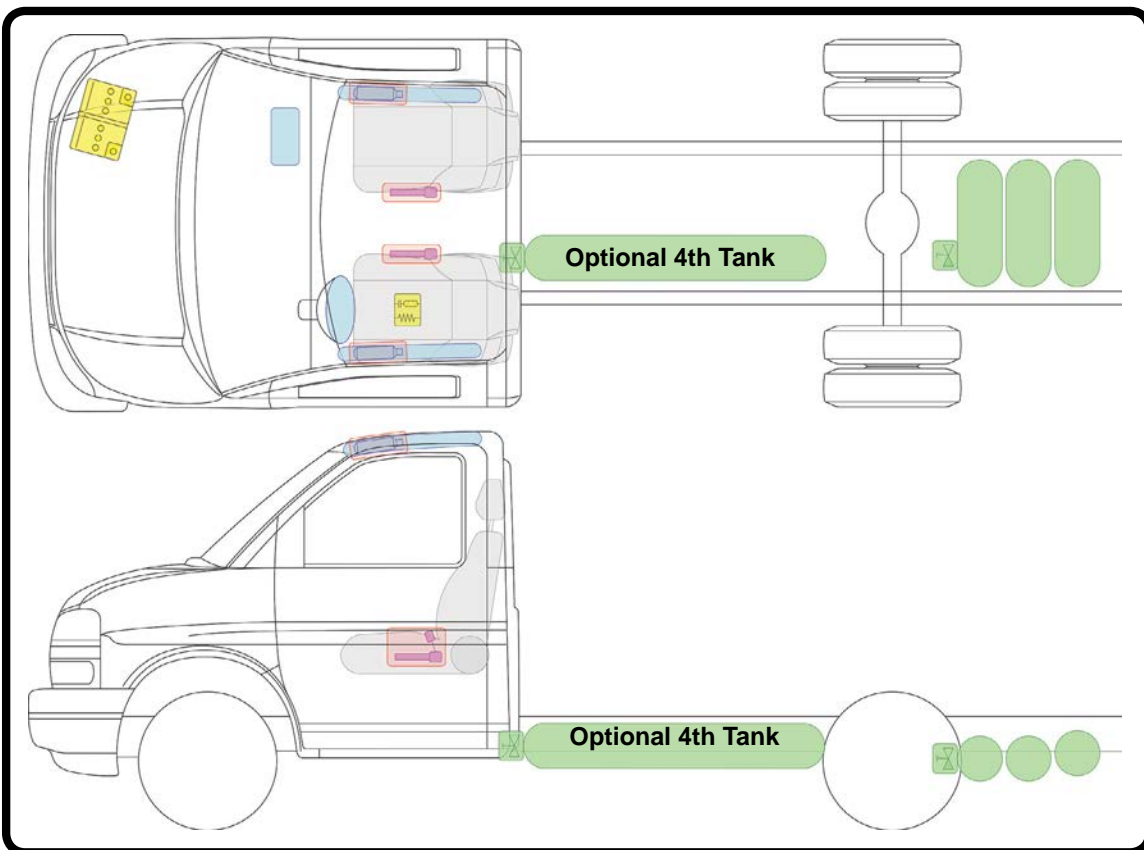

LEGEND			
	Airbag		SRS Control Unit
	Stored Gas Inflator		12V Battery
	Seatbelt Tensioner or Pretensioner		Fuel Tank
			Pressure Relief Valve

For towing and post-incident instructions, see the **POST-INCIDENT** section on page 20.

CHEVROLET EXPRESS



2015-16



CHEVROLET

VEHICLE INFORMATION

CNG
See page 25.

IMMOBILIZE VEHICLE

- 1. **Chock the wheels.**
- 2. **Set parking brake** (foot pedal)
- 3. **Place vehicle into park.** (gear selector, center console)

DISABLE VEHICLE

PRIMARY PROCEDURE

- 1. Turn the ignition key to the OFF position.
- 2. Disconnect both 12V battery cables (engine compartment, driver's side).
- 3. Turn the shut-off valve, 1/4 turn to the OFF position (in front of the left rear wheel opening), so the valve points downward.

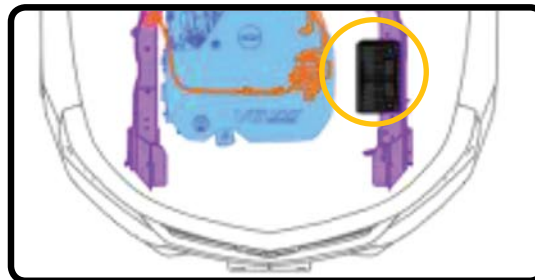

Disconnect the 12V Battery Cables

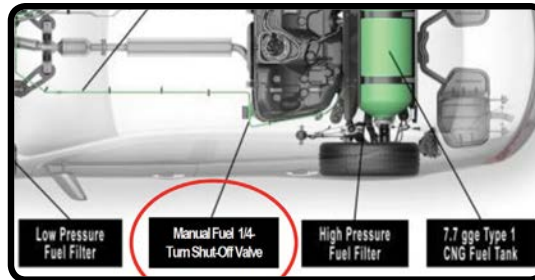

Shut-Off Valve Location



1/4 Turn Shut-Off Valve, Off Points Down

WARNINGS

- Do NOT cut the fuel lines, cutting fuel lines will release the natural gas in the fuel lines.
- Do NOT try to stop a leak by over-tightening any fitting or isolation valve.
- The SRS system (airbags, etc.) may remain powered for up to 1 minute after disabling.
- Natural gas becomes flammable at concentrations between 5% and 15% in air.

CHEVROLET

IMPALA





2015-16



IMPALA

CHEVROLET

CNG
See page 25.

(continued) **EXTRICATION INFORMATION**

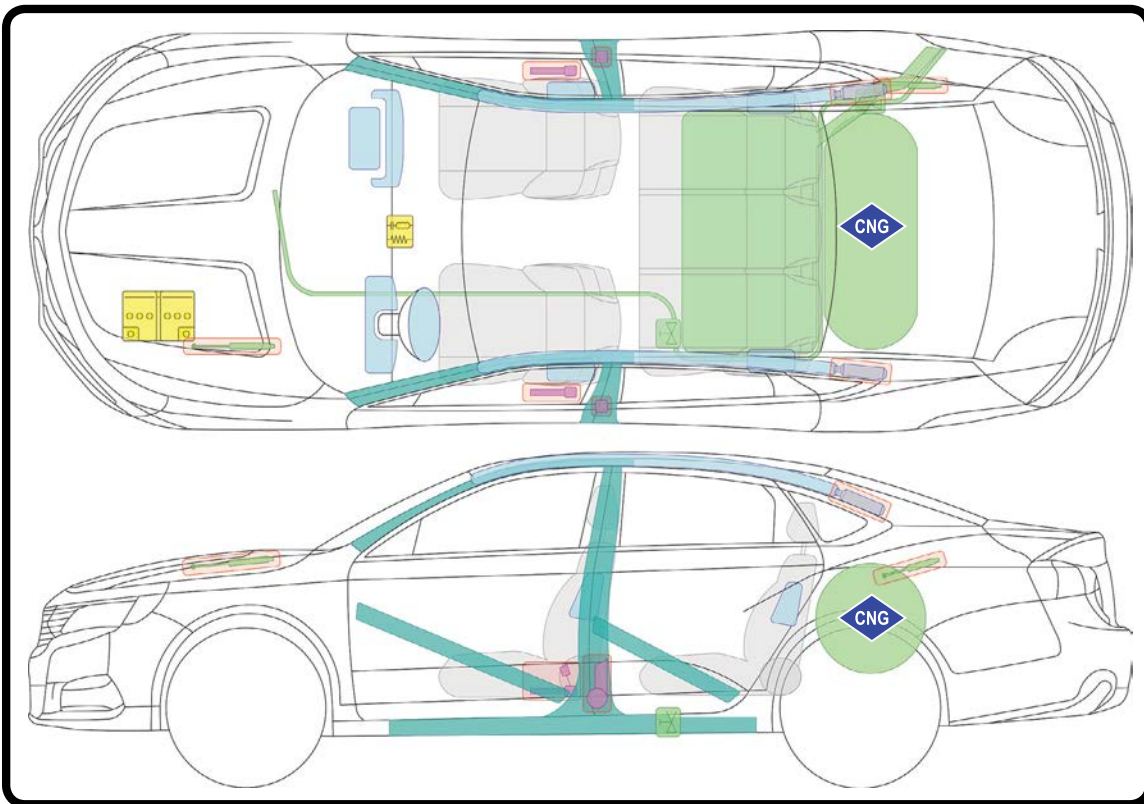

LEGEND		
Airbag	Bodywork Reinforcements	SRS Control Unit
Stored Gas Inflator	Support Cylinder for Hood	12V Battery
Seatbelt Tensioner or Pretensioner	Fuel Tank	Pressure Relief Valve

For towing and post-incident instructions, see the **POST-INCIDENT** section on page 20.



2007-09

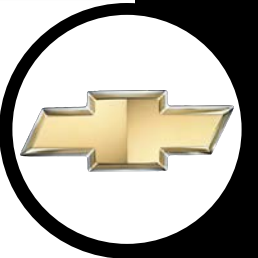

CHEVROLET

VEHICLE INFORMATION

IMMOBILIZE VEHICLE

1. **Chock the wheels.**
2. **Set parking brake.**
(foot pedal)
3. **Place vehicle into park.**
(center console)

DISABLE VEHICLE

Determine if vehicle is ON.

- Vehicle is ON if tachometer needle points to AUTO STOP.
- Vehicle is OFF if needle points to OFF.

PRIMARY PROCEDURE

1. If ON, turn the vehicle's ignition off (conventional key). Remove key.
2. Disconnect the 12V battery, negative cables (engine compartment).

NOTE: Since one of the 12V negative (-) cables is partially hidden from view, it is best to disconnect the cables from the terminal or cut the cables near the terminal.



Cut here to disable BOTH 12V negative cables at once.

ALTERNATE PROCEDURE

1. Disconnect the 12V battery, negative cables (engine compartment).
2. If the ignition key is not accessible, remove the Run/Crank Relay located in the underhood fuse block



Run/Crank Relay

MEDIUM VOLTAGE MANUAL DISCONNECT

Opening the hinged cover of the manual disconnect causes a spring-loaded disconnect switch to interrupt electrical flow from the medium voltage battery and quickly discharge stored electrical energy in the generator control module. (See next page for detail diagram.)

WARNINGS

- NEVER cut medium voltage components or blue cabling. Cutting presents an arc hazard. Medium voltage cabling is routed under vehicle in a metal conduit.
- The high voltage system may remain powered for up to 1 minute after the vehicle is shut off.
- The SRS system (airbags, etc.) may remain powered for up to 1 minute after disabling.
- Lack of engine noise does not mean vehicle is OFF. Silent movement or instant restart capability exists until vehicle is fully shut down.

CHEVROLET



MALIBU



2007-09







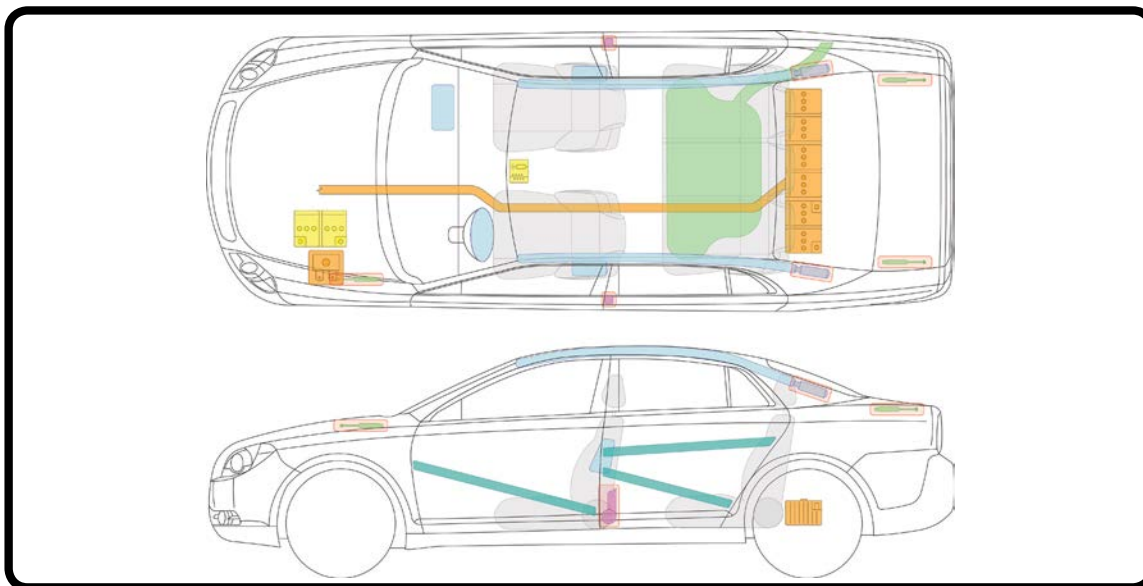

HYBRID

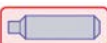

(continued) **EXTRICATION INFORMATION**

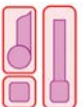

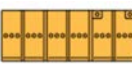
LEGEND

 Airbag	 Bodywork Reinforcements	 SRS Control Unit
 Stored Gas Inflator	 Support Cylinder for Hood	 12V Battery
 Seatbelt Tensioner or Pretensioner	 Fuel Tank	 High-Voltage Power Cable
 High-Voltage Battery	 Emergency Disconnect (Remove Fuse)	

**MEDIUM VOLTAGE
MANUAL DISCONNECT DETAIL**

DO NOT cut the vehicle until all of the electrical systems have been deactivated and isolated. Cutting into the vehicle prior to disconnecting and isolating the electrical energy sources may cause an electrical arc and/or personal injury.

For towing and post-incident instructions, see the **POST-INCIDENT** section on page 20.

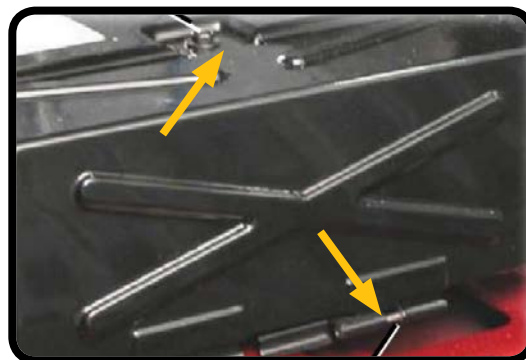

A 10 mm hex bolt secures the module. Hinges are attached to the battery cover.

Malibu

CHEVROLET



2013-15



CHEVROLET

CHEVROLET

MALIBU



With eAssist

VEHICLE INFORMATION

Li-ion
See pages 15, 22.

IMMOBILIZE VEHICLE

- 1. **Chock the wheels.**
- 2. **Set parking brake.**
(push/pull switch, center console)
- 3. **Place vehicle into park.**
(gear selector, center console)

DISABLE VEHICLE

Determine if vehicle is ON.

- Vehicle is ON if tachometer needle points to AUTO STOP.
- Vehicle is OFF if needle points to OFF.

PRIMARY PROCEDURE

- 1. If ON, turn off ignition (steering column key or START/STOP button right of steering column).
- 2. Remove proximity key (if equipped) and keep it at least 16 feet (5 meters) from vehicle.
- 3. Cut black 12V battery cable at yellow cut tape (engine compartment).
- 4. Cut auxiliary power module cable at yellow cut tape (engine compartment).







Yellow Cut Tape Labels

NOTE: To avoid accidental reconnection of cable, remove a section of each.

ALTERNATE PROCEDURE

No alternate procedure is given. However, either step 1 by itself, or steps 3 and 4 combined, should disable both the SRS and HV systems (in the event either the ignition or the engine compartment cut points are not accessible).

WARNINGS

-  NEVER cut, breach, or touch high voltage components or cabling. Doing so could result in serious injury or death.
-  The high voltage system may remain powered for up to 1 minute after the vehicle is shut off.
-  The SRS system (airbags, etc.) may remain powered for up to 1 minute after disabling.
-  Lack of engine noise does not mean vehicle is OFF. Silent movement or instant restart capability exists until vehicle is fully shut down.

HEV

CHEVROLET



2013-15



Li-ion

(continued)

EXTRICATION INFORMATION

See pages 15, 22.

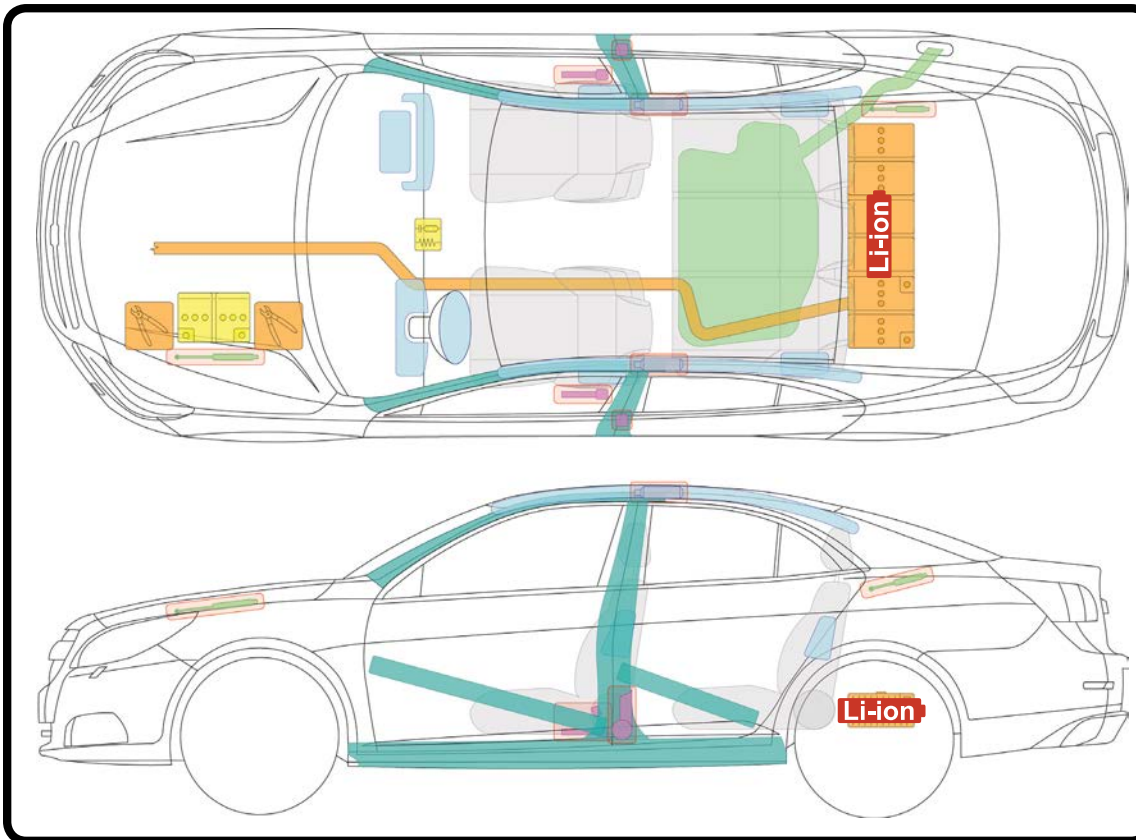

LEGEND

Airbag	Bodywork Reinforcements	SRS Control Unit
Stored Gas Inflator	Support Cylinder for Hood	12V Battery
Seatbelt Tensioner or Pretensioner	Fuel Tank	High-Voltage Power Cable
High-Voltage Battery	Emergency Disconnect (Cut Cable)	

SRS SYSTEM

The Chevrolet Malibu Eco vehicles are equipped with up to 10 airbags and dual pretensioner seat belts that work together with the airbag system.

For towing and post-incident instructions, see the **POST-INCIDENT** section on page 20.



MALIBU

CHEVROLET

with eAssist



2016-19

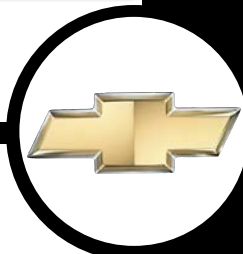

CHEVROLET

VEHICLE INFORMATION

Li-ion

See pages 15, 22.

IMMOBILIZE VEHICLE

1. **Chock the wheels.**
2. **Set parking brake.**
(foot pedal)
3. **Place vehicle into park.**
(gear selector, center console)





DISABLE VEHICLE

Determine if vehicle is ON by illumination of the instrument displays.

PRIMARY PROCEDURE

1. If ON, turn off ignition (push-button, center console).
2. Remove proximity key and keep it at least 16 feet from the vehicle.
3. Double cut all the low voltage cables marked by yellow tape above the 12V battery (driver's side, trunk).

WARNINGS

-  NEVER cut, breach, or touch high voltage components or cabling. Doing so could result in serious injury or death.
-  The high voltage system may remain powered for up to 1 minute after the vehicle is shut off.
-  The SRS system (airbags, etc.) may remain powered for up to 10 seconds after disabling.
-  Lack of engine noise does not mean vehicle is OFF. Silent movement or instant restart capability exists until vehicle is fully shut down.

MALIBU

HEV

CHEVROLET



2016-19



MALIBU

CHEVROLET

Li-ion (continued) **EXTRICATION INFORMATION**

See pages 15, 22.

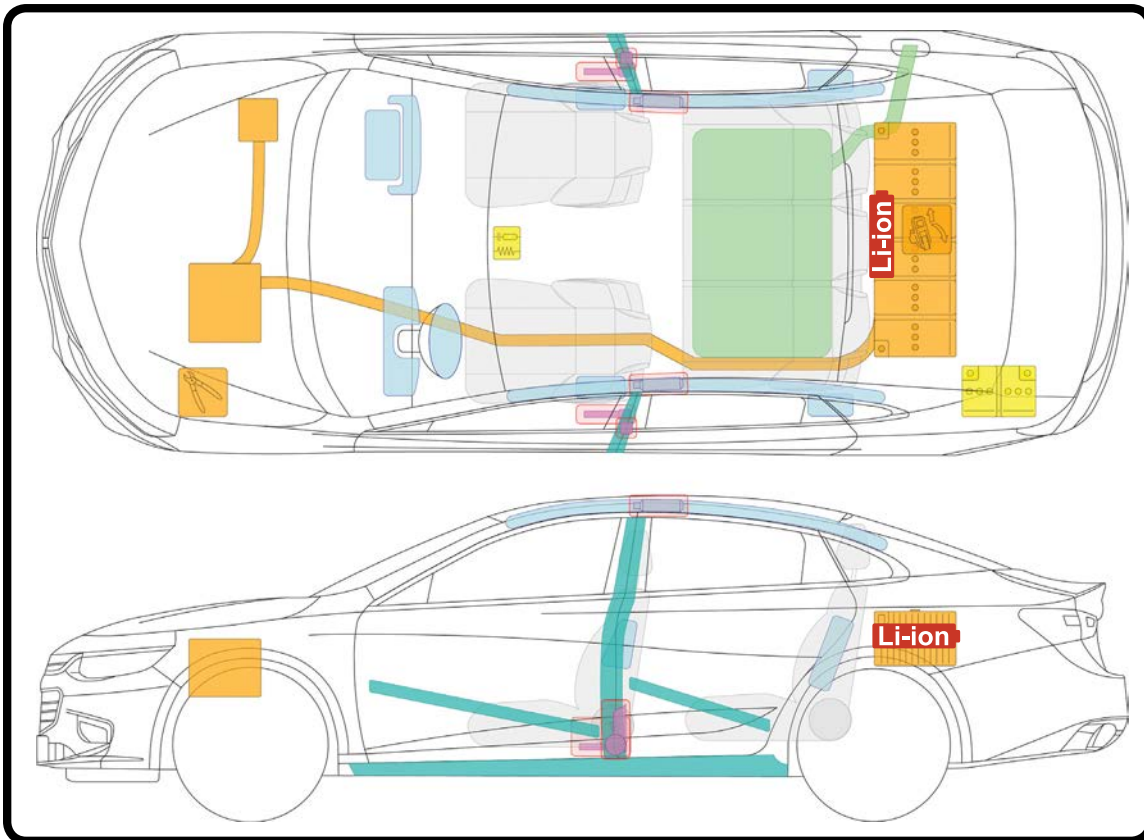

LEGEND		
Airbag	Bodywork Reinforcements	SRS Control Unit
Stored Gas Inflator	Support Cylinder for Hood	12V Battery
Seatbelt Tensioner or Pretensioner	Fuel Tank	High-Voltage Power Cable
High-Voltage Battery	Emergency Disconnect (Cut Cable)	Emergency Disconnect (Remove Plug)

For towing and post-incident instructions, see the **POST-INCIDENT** section on page 20.



2004-07



HYBRID

CHEVROLET

CHEVROLET SILVERADO

VEHICLE INFORMATION

IMMOBILIZE VEHICLE

- 1. **Chock the wheels.**
- 2. **Set parking brake.** (foot pedal)
- 3. **Place vehicle into park.** (steering column)

DISABLE VEHICLE

PRIMARY PROCEDURE

- 1. Turn the vehicle's ignition off (steering column, key). Remove key.
- 2. Turn the Service Disconnect Switch to the OFF (horizontal position), located in the right side of the Energy Storage Box, under rear passengers seat.
- 3. Disconnect 12V negative (-) battery cable, then positive (+) battery cable.
- 4. Ensure the terminal cannot contact the battery post.



Service Disconnect Switch

ALTERNATE PROCEDURE

(if the ignition key is not accessible)

- 1. Turn the Service Disconnect Switch to the OFF (horizontal position), located in the right side of the Energy Storage Box, under rear passengers seat.
- 2. Disconnect 12V negative (-) battery cable, then positive (+) battery cable.
- 3. Ensure the terminal cannot contact the battery post.

WARNINGS

- NEVER cut, breach, or touch orange high voltage components or cabling. Doing so could result in serious injury or death.
- The high voltage system may remain powered for up to 1 minute after the vehicle is shut off.
- The SRS system (airbags, etc.) may remain powered for up to 1 minute after disabling.
- Lack of engine noise does not mean vehicle is OFF. Silent movement or instant restart capability exists until vehicle is fully shut down.











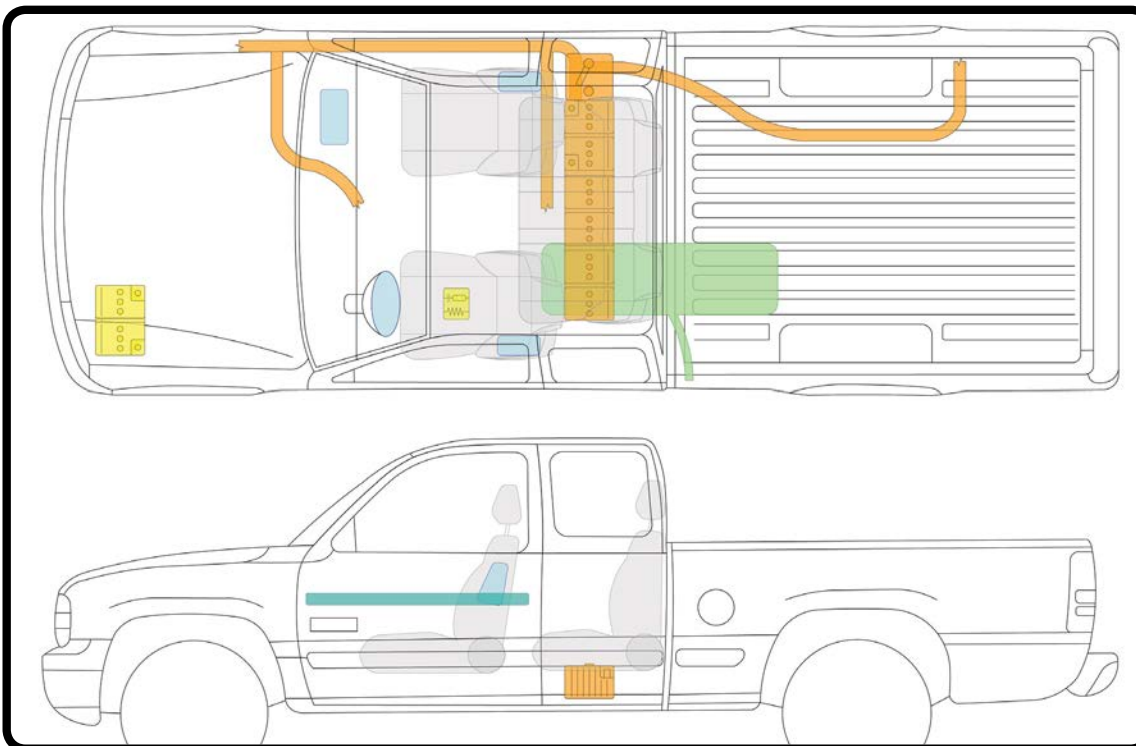

2004-07

HYBRID

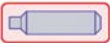

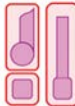
(continued) **EXTRICATION INFORMATION**

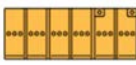

LEGEND		
 Airbag	 Bodywork Reinforcements	 SRS Control Unit
 Stored Gas Inflator		 12V Battery
 Seatbelt Tensioner or Pretensioner	 Fuel Tank	 High-Voltage Power Cable
 High-Voltage Battery	 Emergency Disconnect (Switch Off)	

NEUTRALIZING THE 120 VAC OUTLETS

1. If the 120 VAC APO indicator is ON, depress the APO button.
2. Turn off Engine (Remove key).

For towing and post-incident instructions, see the **POST-INCIDENT** section on page 20.



120 VAC Outlets



2009-13



CHEVROLET

CHEVROLET SILVERADO

VEHICLE INFORMATION

IMMOBILIZE VEHICLE

1. Chock the wheels.
2. Set parking brake.
3. Place vehicle into park. (steering column)

DISABLE VEHICLE

Determine if vehicle is ON.

- Vehicle is ON if tachometer needle points to AUTO STOP.
- Vehicle is OFF if needle points to OFF.

PRIMARY PROCEDURE

1. If ON, turn the vehicle's ignition off (steering column, key). Remove key.
2. Disconnect 12V positive (+) battery cable (engine compartment, driver's side). 12V battery has lever-type quick release terminals.
3. Ensure the terminal cannot contact the battery post.

ALTERNATE PROCEDURE

(if the ignition key is not accessible)

1. Disconnect the 12V positive (+) battery cable (engine compartment, driver's side).
2. Cut all three exposed 12V positive cables identified by the yellow First Responder labels.



Cut 3 Exposed Cables (Alternate Procedure)





HIGH VOLTAGE MANUAL DISCONNECT

If accessible, you can minimize potential for high voltage current flow by removing the manual disconnect lever from the high voltage battery. It is located under the passenger's side, second row, rear sub-floor.



300V Hybrid Battery Manual Disconnect

WARNINGS

-  NEVER cut, breach, or touch orange high voltage components or cabling. Doing so could result in serious injury or death.
-  The high voltage system may remain powered for up to 1 minute after the vehicle is shut off.
-  The SRS system (airbags, etc.) may remain powered for up to 1 minute after disabling.
-  Lack of engine noise does not mean vehicle is OFF. Silent movement or instant restart capability exists until vehicle is fully shut down.

HEV

CHEVROLET

SILVERADO

CHEVROLET









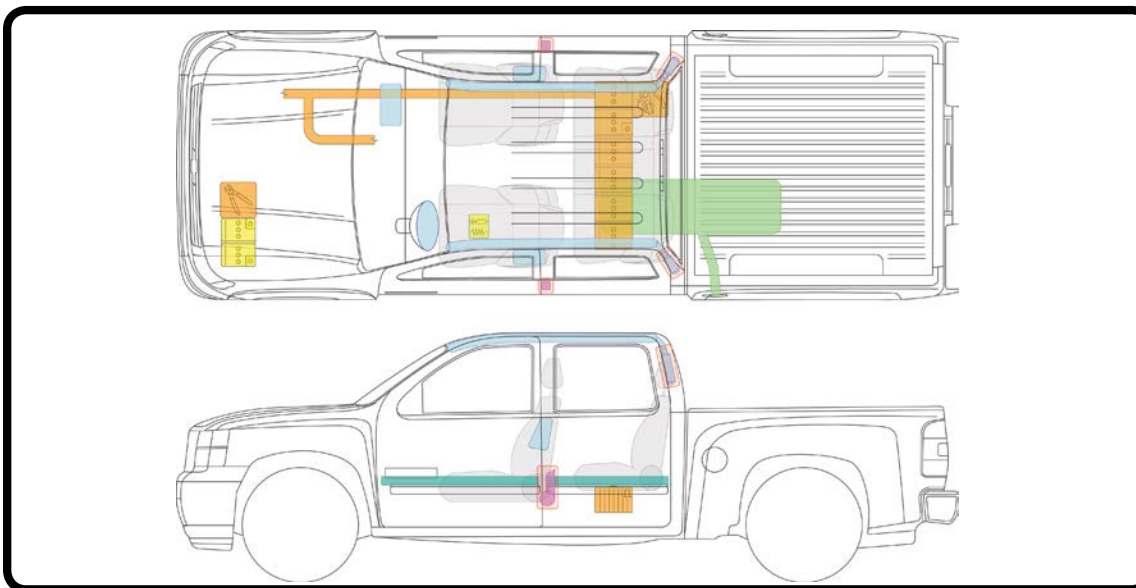



2009-13



(continued) **EXTRICATION INFORMATION**

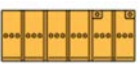

LEGEND		
 Airbag	 Bodywork Reinforcements	 SRS Control Unit
 Stored Gas Inflator		 12V Battery
 Seatbelt Tensioner or Pretensioner	 Fuel Tank	 High-Voltage Power Cable
 High-Voltage Battery	 Emergency Disconnect (Cut Cable)	 Emergency Disconnect (Remove Plug)

REMOVING THE SERVICE DISCONNECT (DETAIL)



1. Pull Up

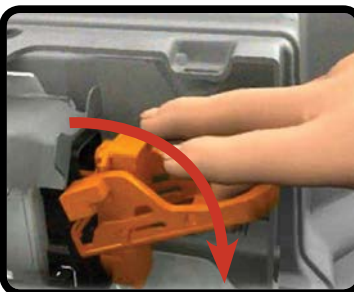

2. Pull Down

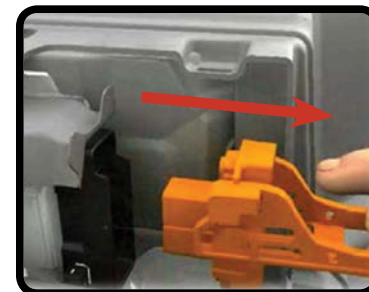

3. Pull Out

For towing and post-incident instructions, see the **POST-INCIDENT** section on page 20.



2015



CHEVROLET

VEHICLE INFORMATION

 See page 25.

IMMOBILIZE VEHICLE

- 1. Chock the wheels.
- 2. Set parking brake. (foot pedal)
- 3. Place vehicle into park. (steering column)

DISABLE VEHICLE

PRIMARY PROCEDURE

- 1. Turn the ignition key to the OFF position.
- 2. Disconnect negative 12V battery cable (engine compartment, passenger's side).
- 3. Turn the isolation valve, counter clockwise to the OFF position (diamond plate access panel in bed of truck, driver side).

NOTE: This is a bi-fuel vehicle and can run on both compressed natural gas (CNG) and regular gasoline.

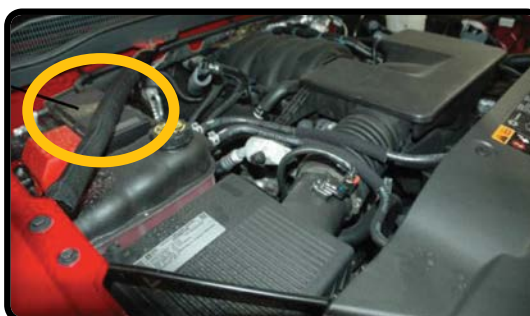

Disconnect 12V Negative Battery Cable







Turn Isolation Valve Counter Clockwise



Manual CNG Shut-Off

WARNINGS

-  Do NOT cut the fuel lines, cutting fuel lines will release the natural gas in the fuel lines.
-  Do NOT try to stop a leak by over-tightening any fitting or isolation valve.
-  The SRS system (airbags, etc.) may remain powered for up to 1 minute after disabling.
-  Natural gas becomes flammable at concentrations between 5% and 15% in air.

CHEVROLET SILVERADO



2015



CHEVROLET SILVERADO

See page 25.

(continued)

EXTRICATION INFORMATION

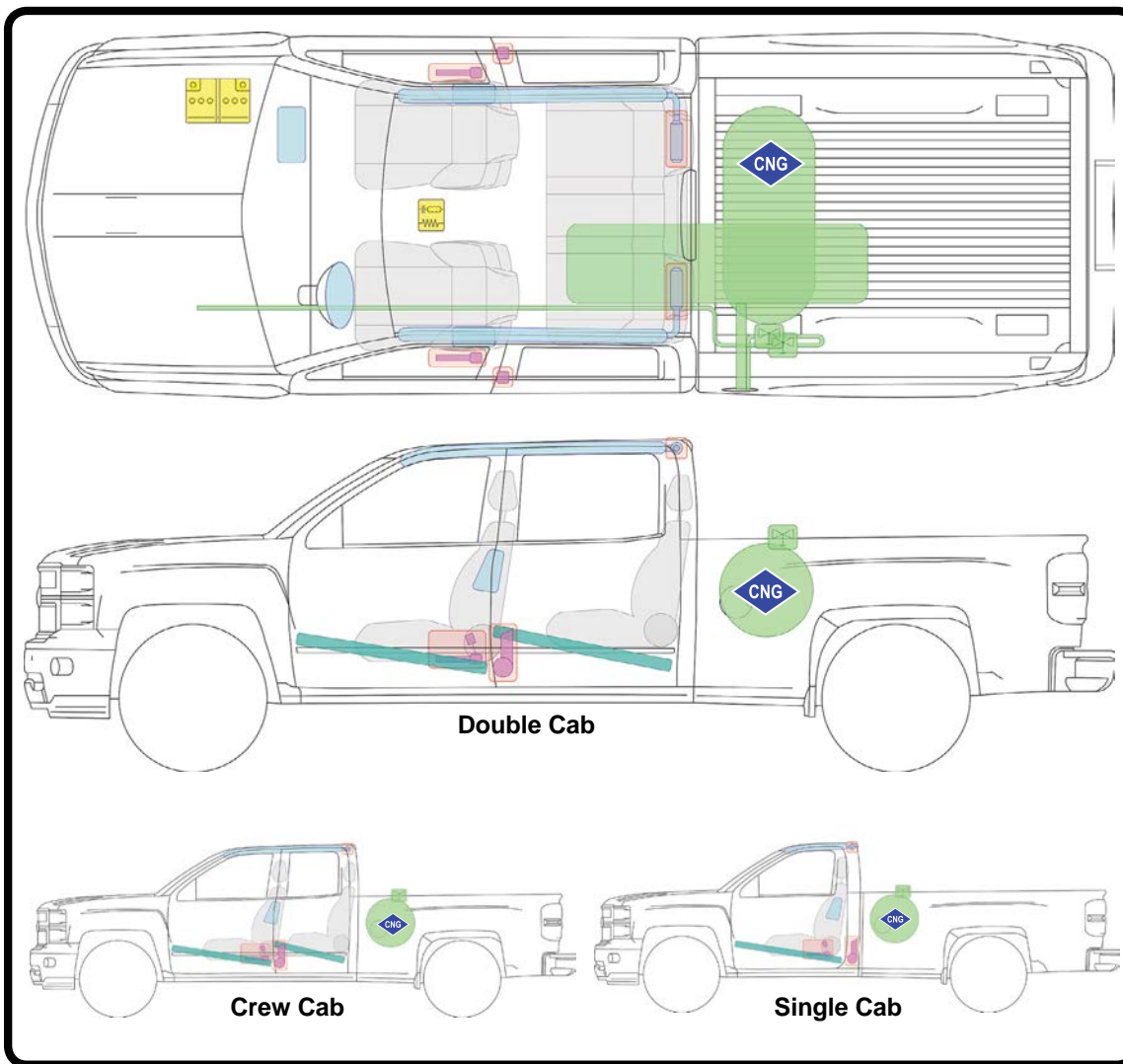

LEGEND		
	Airbag	
	Stored Gas Inflator	
	Seatbelt Tensioner or Pretensioner	
	Bodywork Reinforcements	

For towing and post-incident instructions, see the **POST-INCIDENT** section on page 20.



2016-18



CHEVROLET

VEHICLE INFORMATION

Li-ion

See pages 15, 22.

IMMOBILIZE VEHICLE

- 1. **Chock the wheels.**
- 2. **Set parking brake.**
(foot pedal)
- 3. **Place vehicle into park.**
(steering column)

DISABLE VEHICLE

Determine if vehicle is ON by illumination of the instrument displays.

PRIMARY PROCEDURE

- 1. Turn the ignition key to the OFF position.
- 2. Remove key.
- 3. Double cut all the low voltage cables marked by yellow tape above the 12V battery (passenger's side, engine compartment).



Cut All Marked Low Voltage Cables

WARNINGS

- NEVER cut, breach, or touch orange high voltage components or cabling. Doing so could result in serious injury or death.
- The high voltage system may remain powered for up to 1 minute after the vehicle is shut off.
- The SRS system (airbags, etc.) may remain powered for up to 10 seconds after disabling.
- Lack of engine noise does not mean vehicle is OFF. Silent movement or instant restart capability exists until vehicle is fully shut down.

CHEVROLET SILVERADO with eAssist











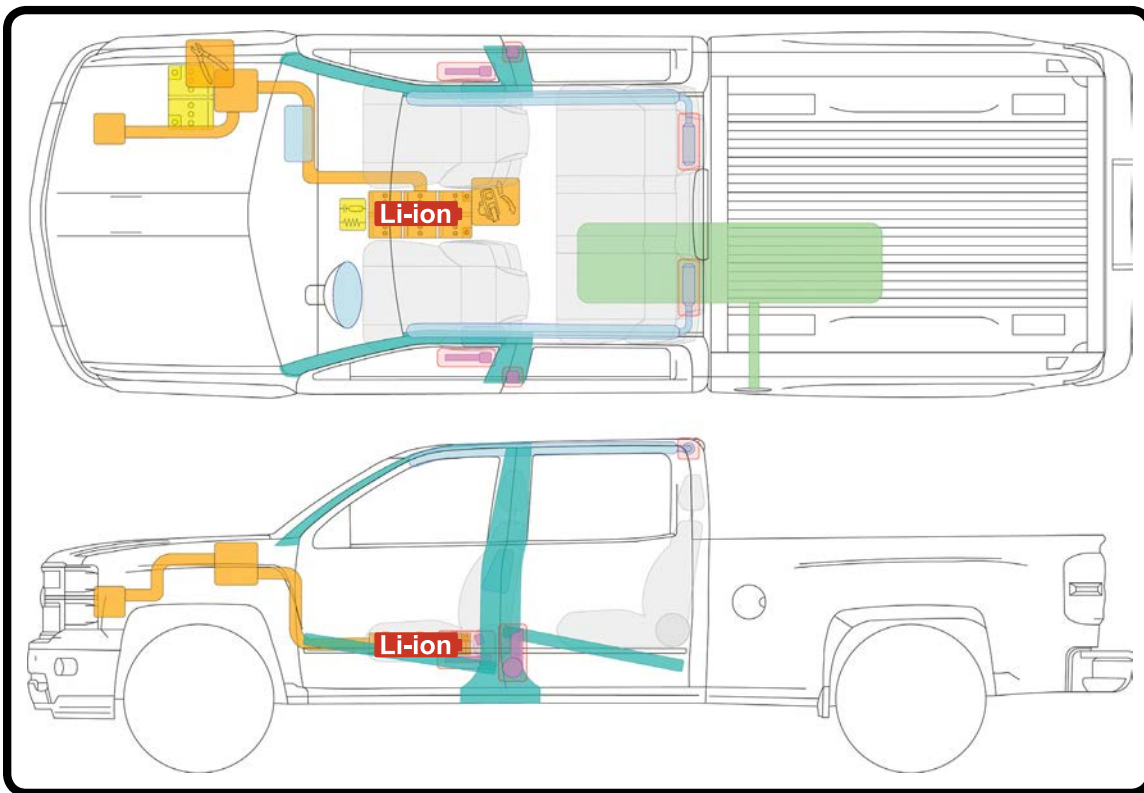



2016-18

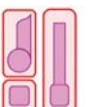

Li-ion (continued) **EXTRICATION INFORMATION**

See pages 15, 22.



LEGEND			
 Airbag	 Bodywork Reinforcements	 SRS Control Unit	
 Stored Gas Inflator		 12V Battery	
 Seatbelt Tensioner or Pretensioner	 Fuel Tank	 High-Voltage Power Cable	
 High-Voltage Battery	 Emergency Disconnect (Cut Cable)	 Emergency Disconnect (Remove Plug)	

For towing and post-incident instructions, see the **POST-INCIDENT** section on page 20.



2014-16



CHEVROLET

VEHICLE INFORMATION

Li-ion
See pages 15, 22.

IMMOBILIZE VEHICLE

1. **Chock the wheels.**
2. **Set parking brake.**
(electric parking brake switch, center console)
3. **Place vehicle into park.**
(gear selector, center console)

DISABLE VEHICLE

Determine if vehicle is ON by presence of READY indicator below speedometer.

PRIMARY PROCEDURE

1. If ON, turn off ignition (push-button, center console).
2. Remove proximity key and keep it at least 16 feet from the vehicle.
3. Cut the 12V wire harness at the yellow tag cut position (behind the strut tower, engine compartment, passengers side).

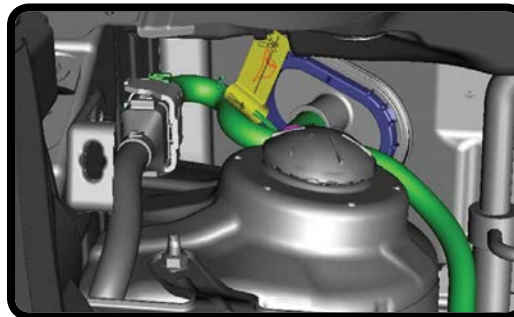

12V Wire Harness Behind Tower Strut, Engine Compartment, Passenger's Side

ALTERNATE PROCEDURE

1. Cut the 12V wire harness at the yellow tag cut position (behind the strut tower, engine compartment, passengers side).
2. Remove the Manual Service Disconnect (located underneath the rear seat cushion).

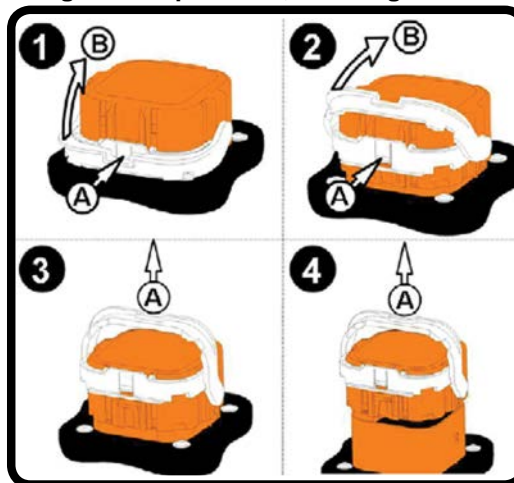

Manual High Voltage Disconnect Located Under Rear Seat Cushion

HIGH VOLTAGE MANUAL DISCONNECT

You can minimize potential for high voltage current flow by removing the Manual Service Disconnect from the high voltage battery (located underneath the rear seat cushion).

WARNINGS

- NEVER cut, breach, or touch orange high voltage components or cabling. Doing so could result in serious injury or death.
- The high voltage system may remain powered for up to 1 minute after the vehicle is shut off.
- The SRS system (airbags, etc.) may remain powered for up to 1 minute after disabling.
- This vehicle does not have an internal combustion engine. Lack of engine noise does not mean vehicle is OFF. Silent movement capability exists until vehicle is fully shut down.

CHEVROLET

SPARK



EV

CHEVROLET



SPARK

CHEVROLET

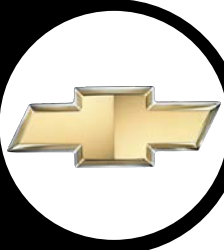

2014-16



Li-ion (continued) **EXTRICATION INFORMATION**

See pages 15, 22.

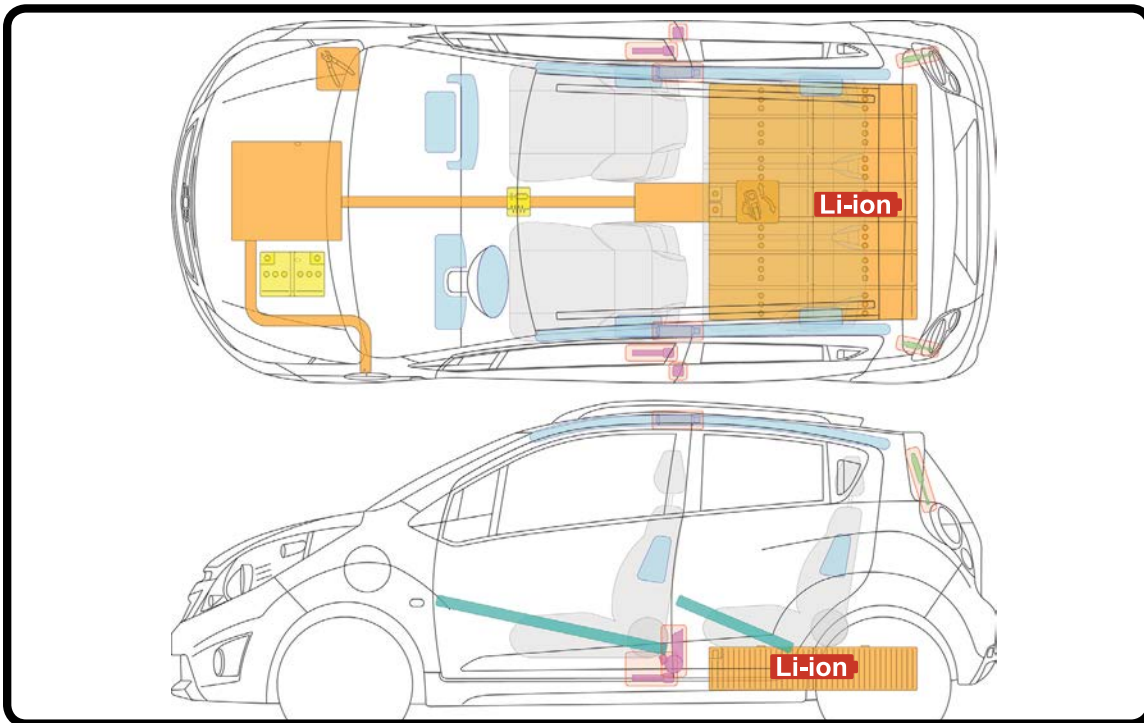

LEGEND

Airbag	Bodywork Reinforcements	SRS Control Unit
Stored Gas Inflator	Support Cylinder for Hood	12V Battery
Seatbelt Tensioner or Pretensioner		High-Voltage Power Cable
High-Voltage Battery	Emergency Disconnect (Cut Cable)	Emergency Disconnect (Remove Plug)

SPECIAL CONCERNS

A PLUGGED IN VEHICLE

If the vehicle is plugged in for charging, you should first unplug it. If access to unplug the vehicle is unavailable, “remove charge power” from the vehicle (done by turning off the power to the charge station).



Vehicle Charging Plug

For towing and post-incident instructions, see the **POST-INCIDENT** section on page 20.



2008-14



CHEVROLET

CHEVROLET TRAILBLAZER

VEHICLE INFORMATION

IMMOBILIZE VEHICLE

1. Chock the wheels.
2. Set parking brake.
3. Place vehicle into park. (steering column)

DISABLE VEHICLE

Determine if vehicle is ON.

- Vehicle is ON if tachometer needle points to AUTO STOP.
- Vehicle is OFF if needle points to OFF.

PRIMARY PROCEDURE

1. If ON, turn the vehicle's ignition off (steering column, key). Remove key.
2. Disconnect 12V positive (+) battery cable (engine compartment, driver's side). 12V battery has lever-type quick release terminals.
3. Ensure the terminal cannot contact the battery post.

ALTERNATE PROCEDURE

(if the ignition key is not accessible)

1. Disconnect the 12V positive (+) battery cable (engine compartment, driver's side).
2. Cut all three exposed 12V positive cables identified by the yellow First Responder labels.



Cut 3 Exposed Cables (Alternate Procedure)

HIGH VOLTAGE MANUAL DISCONNECT

If accessible, you can minimize potential for high voltage current flow by removing the manual disconnect lever from the high voltage battery. It is located under the passenger's side, second row, rear sub-floor.



300V Hybrid Battery Manual Disconnect

WARNINGS

- NEVER cut, breach, or touch orange high voltage components or cabling. Doing so could result in serious injury or death.
- The high voltage system may remain powered for up to 1 minute after the vehicle is shut off.
- The SRS system (airbags, etc.) may remain powered for up to 1 minute after disabling.
- Lack of engine noise does not mean vehicle is OFF. Silent movement or instant restart capability exists until vehicle is fully shut down.



2008-14



(continued) **EXTRICATION INFORMATION**

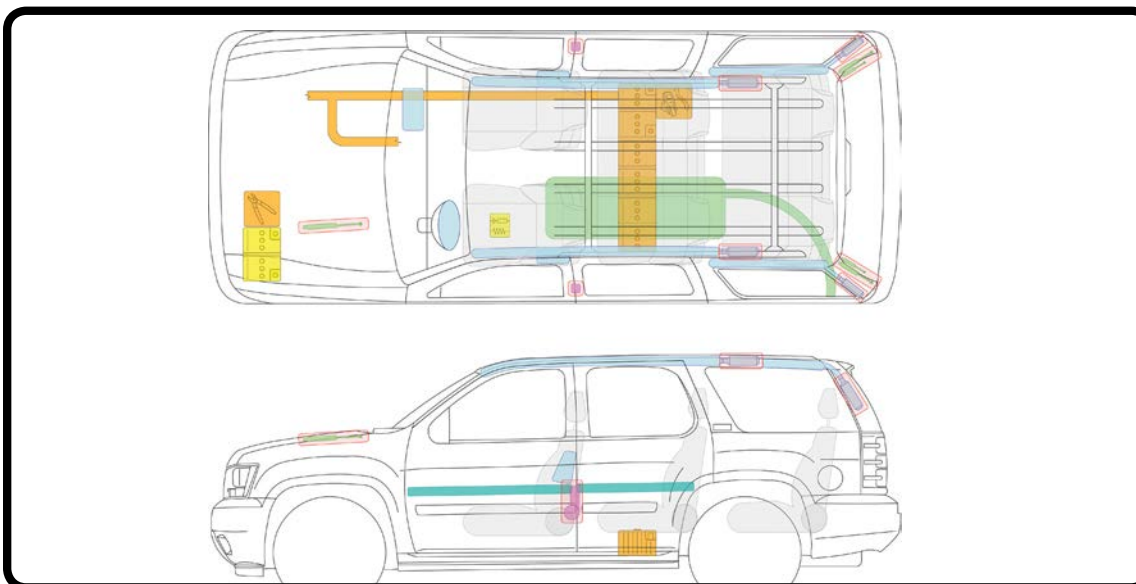

LEGEND		
Airbag	Bodywork Reinforcements	SRS Control Unit
Stored Gas Inflator	Support Cylinder for Hood	12V Battery
Seatbelt Tensioner or Pretensioner	Fuel Tank	High-Voltage Power Cable
High-Voltage Battery	Emergency Disconnect (Cut Cable)	Emergency Disconnect (Remove Plug)

REMOVING THE SERVICE DISCONNECT (DETAIL)



1. Pull Up

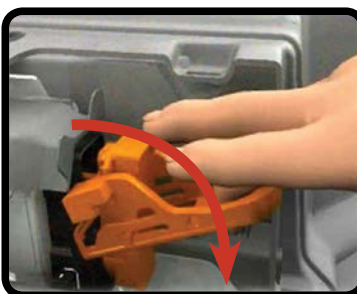

2. Pull Down

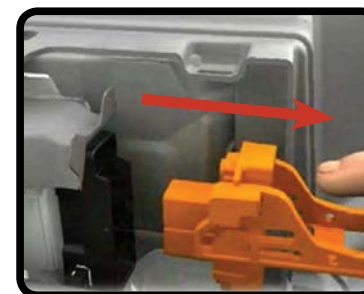

3. Pull Out

For towing and post-incident instructions, see the **POST-INCIDENT** section on page 20.



2011-15



VOLT

CHEVROLET

VEHICLE INFORMATION

Li-ion

See pages 15, 22.

IMMOBILIZE VEHICLE

1. **Chock the wheels.**
2. **Set parking brake.**
(push/pull switch, center console)
3. **Place vehicle into park.**
(center console)

DISABLE VEHICLE

Determine if vehicle is ON by illumination of the instrument displays.

PRIMARY PROCEDURE

1. If ON, turn off ignition (push-button, center console). Remove key.
2. Cut the 12V positive battery cable at the yellow tag cut position (behind left rear panel in rear cargo compartment).

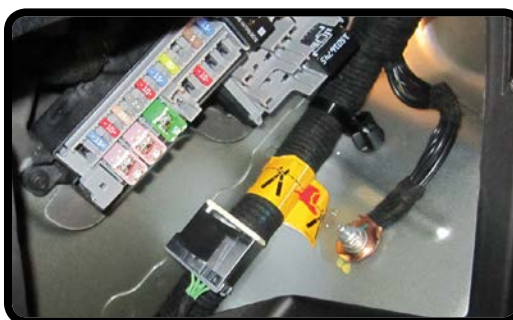

Cut through the positive 12V cable on each side of the tag to remove a section of the cable to ensure the cables cannot inadvertently reconnect.

ALTERNATE PROCEDURE 1

1. Turn off ignition (push-button, center console).
2. Remove manual service disconnect (located under tray in center console).

ALTERNATE PROCEDURE 2

If ignition cannot be accessed,

1. Cut the 12V battery red POSITIVE cable at the cut-tape indicator (behind left rear panel in rear cargo compartment).
2. Remove manual service disconnect (located under tray in center console).

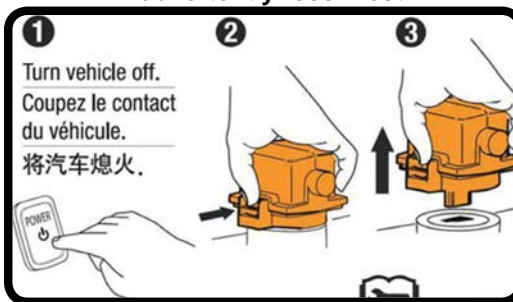

Manual High Voltage Disconnect Located Under Center Console

WARNINGS

- NEVER cut, breach, or touch orange high voltage components or cabling. Doing so could result in serious injury or death.
- The high voltage system may remain powered for up to 1 minute after the vehicle is shut off.
- The SRS system (airbags, etc.) may remain powered for up to 1 minute after disabling.
- The outboard area of the front seat lower frame houses an additional seat belt pretensioner.
- In the event a Volt is involved in an incident while connected to a charging station, remove the charge cord from the car at the charge port in the left front fender. If that cannot be accomplished, the electrical power to the charge cord should be terminated at the source.
- In the event of a fire involving a charging station, reference the **FIRE** portion of this guide, and treat it as an energized electrical fire until power to the charger can be shut down.

VOLT



2011-15

VOLT



Li-ion (continued) **EXTRICATION INFORMATION**

See pages 15, 22.

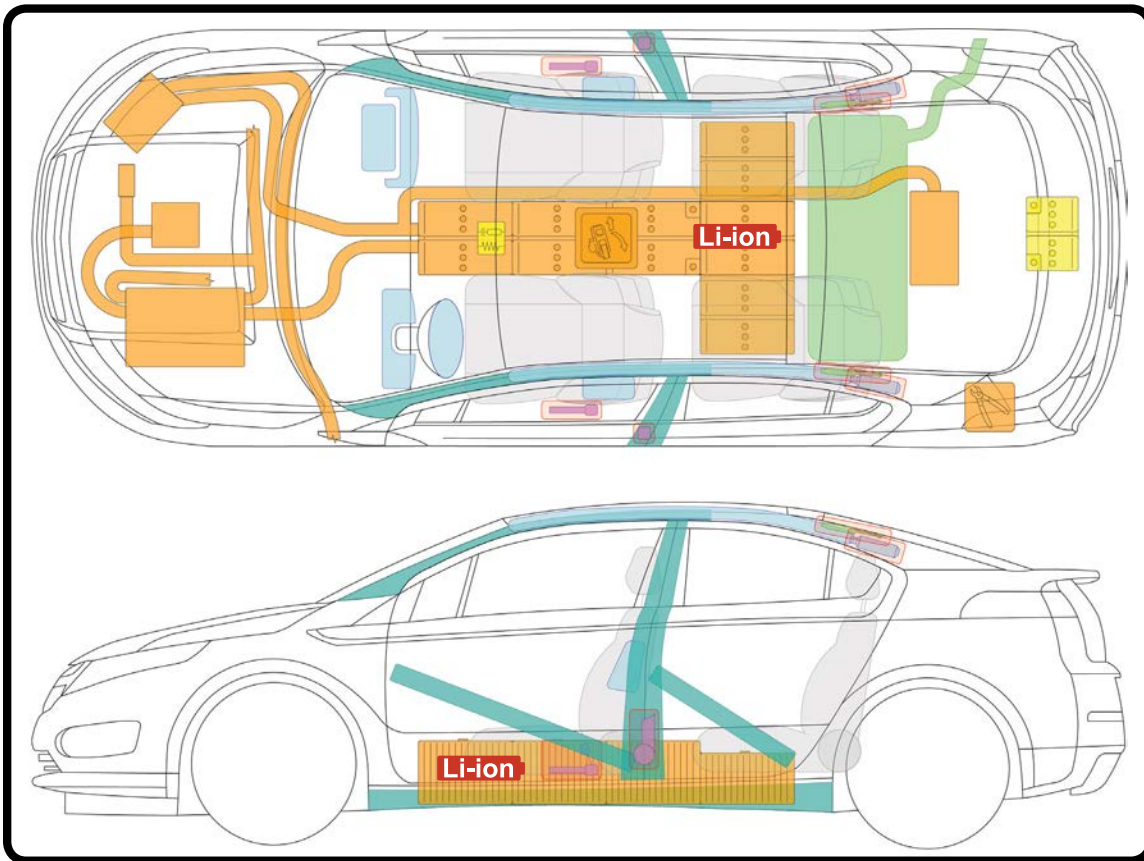

LEGEND		
Airbag	Bodywork Reinforcements	SRS Control Unit
Stored Gas Inflator	Support Cylinder for Hood	12V Battery
Seatbelt Tensioner or Pretensioner	Fuel Tank	High-Voltage Power Cable
High-Voltage Battery	Emergency Disconnect (Cut Cable)	Emergency Disconnect (Remove Plug)

For towing and post-incident instructions, see the **POST-INCIDENT** section on page 20.



2016-19

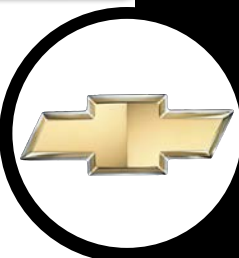

VOLT

CHEVROLET

CHEVROLET

VEHICLE INFORMATION

Li-ion

See pages 15, 22.

IMMOBILIZE VEHICLE

1. **Chock the wheels.**
2. **Set parking brake.**
(push/pull switch, center console)
3. **Place vehicle into park.**
(center console)

DISABLE VEHICLE

Determine if vehicle is ON by illumination of the instrument displays.





PRIMARY PROCEDURE

1. If ON, turn off ignition (push-button, center console).
2. Remove proximity key and keep it at least 16 feet from the vehicle.
3. Cut the 12V positive battery cable at the yellow tag cut position (behind left rear panel in rear cargo compartment).



Cut through the positive 12V cable on each side of the tag to remove a section of the cable to ensure the cables cannot inadvertently reconnect.

WARNINGS

-  NEVER cut, breach, or touch orange high voltage components or cabling. Doing so could result in serious injury or death.
-  The high voltage system may remain powered for up to 1 minute after the vehicle is shut off.
-  The SRS system (airbags, etc.) may remain powered for up to 10 seconds after disabling.
-  In the event a Volt is involved in an incident while connected to a charging station, remove the charge cord from the car at the charge port in the left front fender. If that cannot be accomplished, the electrical power to the charge cord should be terminated at the source.
-  In the event of a fire involving a charging station, reference the **FIRE** portion of this guide, and treat it as an energized electrical fire until power to the charger can be shut down.

VOLT



2016-19

VOLT







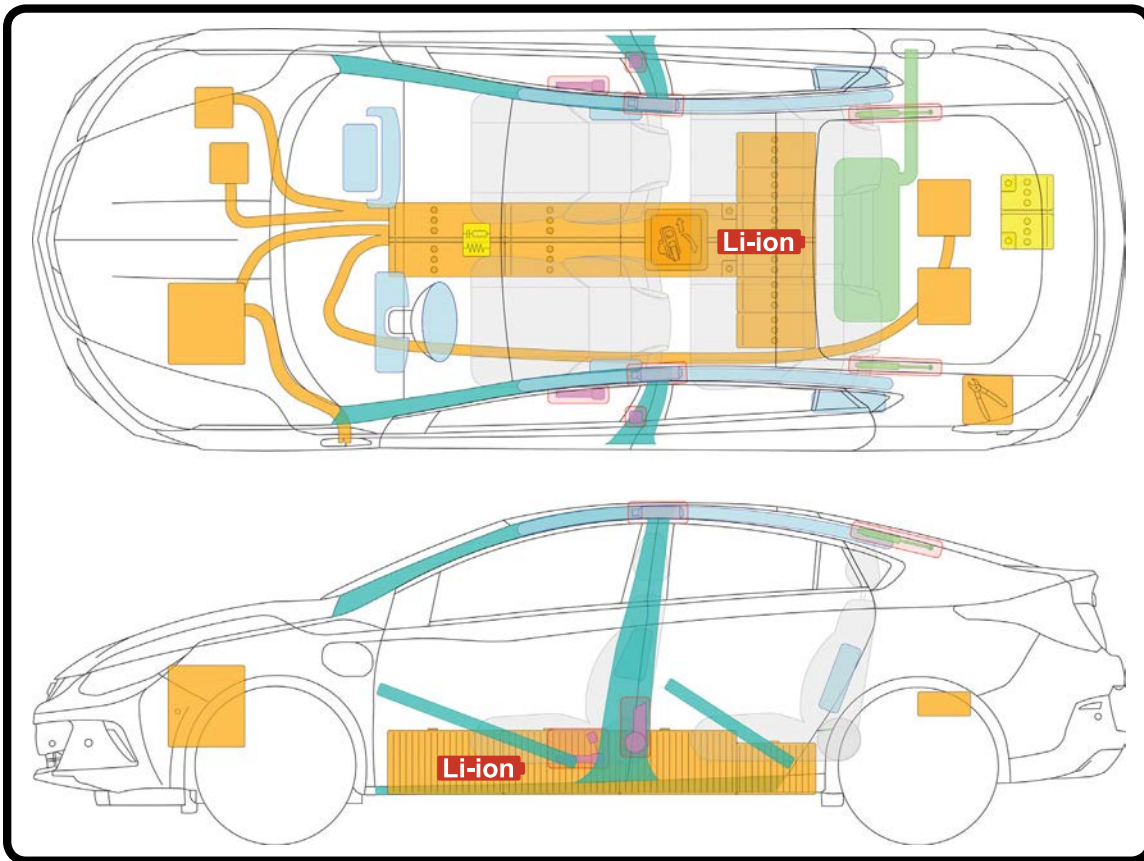



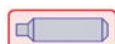

Li-ion (continued) **EXTRICATION INFORMATION**

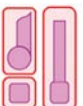
See pages 15, 22.



LEGEND

 Airbag	 Bodywork Reinforcements	 SRS Control Unit
 Stored Gas Inflator	 Support Cylinder for Hood	 12V Battery
 Seatbelt Tensioner or Pretensioner	 Fuel Tank	 High-Voltage Power Cable
 High-Voltage Battery	 Emergency Disconnect (Cut Cable)	 Emergency Disconnect (Remove Plug)

For towing and post-incident instructions, see the **POST-INCIDENT** section on page 20.



2009

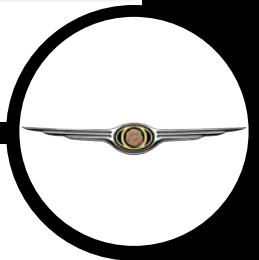

HYBRID
TWO MODE HEMI

VEHICLE INFORMATION

IMMOBILIZE VEHICLE

- 1. **Chock the wheels.**
- 2. **Set parking brake.**
(foot pedal)
- 3. **Place vehicle into park.**
(steering column)

DISABLE VEHICLE

Determine if vehicle is ON by presence of READY indicator on speedometer or any reading on Hybrid Economy gauge (right of speedometer).

PRIMARY PROCEDURE

- 1. If ON, turn the vehicle's ignition off (key, steering column). Remove key.
- 2. Disconnect or cut the 12V battery negative cable. The 12V battery is located beneath the vehicle and is difficult to access directly. There is a 12V battery low-voltage disconnect that can be accessed in the engine compartment (adjacent to the air cleaner on the driver's side of the engine).



12V Battery Disconnect

ALTERNATE PROCEDURE

- 1. Remove the high voltage service disconnect located on driver's side front of high voltage battery (under second row seat).



HV System Disconnect

WARNING: Removing the service disconnect alone does not disable the 12V system, and therefore will not disable the airbag and SRS system. In order to disable the airbag system, cut or disconnect the 12V battery negative cable.

WARNINGS

- NEVER cut, breach, or touch high voltage components or cabling. Doing so could result in serious injury or death.
- If an automatic shut-off is triggered by a crash, the high voltage system should be de-energized within 5 seconds. If manually shut-off, de-energizing the high voltage system capacitors could take up to 5 minutes. Always treat the high voltage system as if it is energized. The high voltage battery will remain energized regardless of shutdown.
- Disable 12V power to shut down airbag system. Even if airbags have deployed, they may be capable of a second deployment.
- Lack of engine noise does not mean vehicle is OFF. Silent movement or instant restart capability exists until vehicle is fully shut down.

CHRYSLER ASPEN

CHRYSLER



2009







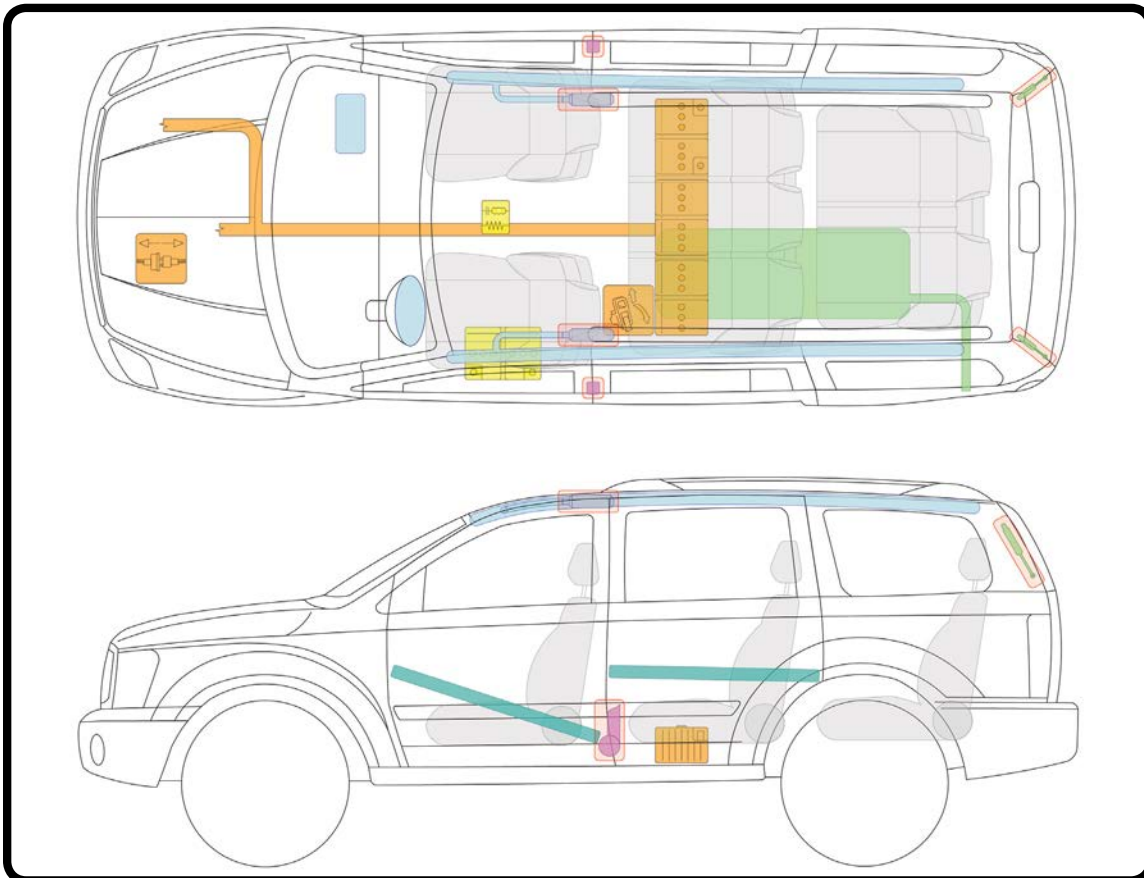

HYBRID
TWO MODE HEMI

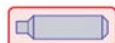

CHRYSLER ASPEN

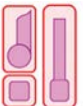
(continued) **EXTRICATION INFORMATION**

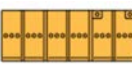

LEGEND		
 Airbag	 Bodywork Reinforcements	 SRS Control Unit
 Stored Gas Inflator	 Support Cylinder for Hood	 12V Battery
 Seatbelt Tensioner or Pretensioner	 Fuel Tank	 High-Voltage Power Cable
 High-Voltage Battery	 Emergency Disconnect (Remove Plug)	 Emergency Disconnect (Disconnect Plug)

For towing and post-incident instructions, see the **POST-INCIDENT** section on page 20.



2017-18



VEHICLE INFORMATION

Li-ion

See pages 15, 22.

IMMOBILIZE VEHICLE

1. Chock the wheels.
2. Set parking brake. (push button, on dash right of steering column)
3. Place vehicle into park. (gear selector, on dash right of steering column)

DISABLE VEHICLE

Determine if vehicle is ON by illumination of instrument displays and START/STOP button on dash right of steering column.

PRIMARY PROCEDURE

1. If ON, turn vehicle off by pressing START/STOP button (on dash right of steering column). Remove the proximity key at least 20 feet from vehicle.
2. Cut and remove a segment of the 12V positive supply cable (located in the engine compartment under cover).

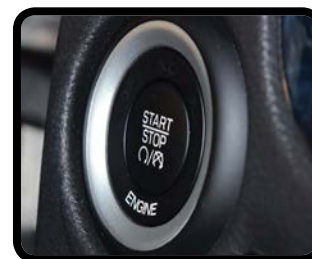

Start/Stop Button

ALTERNATE PROCEDURE

(if engine compartment is not accessible)

1. Cut and remove segment of 12V negative battery cable (located in compartment in rear of vehicle on the driver's side, remove trim to access).
2. Remove the high voltage service disconnect, located in the center floorboard of the second row seats.

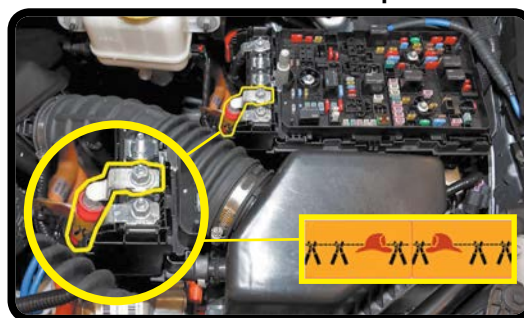

12V Positive Supply Cable

WARNING: Removing the service disconnect alone does not disable the 12V system or the airbag and SRS system. In order to disable the airbag system, cut or disconnect the 12V battery negative cable.





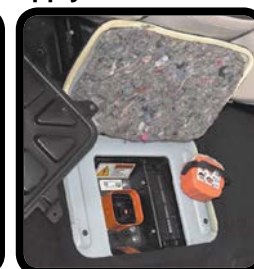

12V Battery Location



HV Disconnect

WARNINGS

-  NEVER cut, breach, or touch high voltage components or cabling. Doing so could result in serious injury or death.
-  De-energizing the high voltage system capacitors could take up to 5 minutes. Always treat the system as if it is energized. The high voltage battery will remain energized regardless.
-  Disable 12V power to shut down airbag system. Even if airbags have deployed, they may be capable of a second deployment.
-  In the event of a fire involving a charging station, reference the **FIRE** portion of this guide, and treat it as an energized electrical fire until power to the charger can be shut down.
-  Lack of engine noise does not mean vehicle is OFF. Silent movement or instant restart capability exists until vehicle is fully shut down.

CHRYSLER PACIFICA

CHRYSLER

2017-18



CHRYSLER

PACIFICA

Li-ion (continued) **EXTRICATION INFORMATION**

See pages 15, 22.

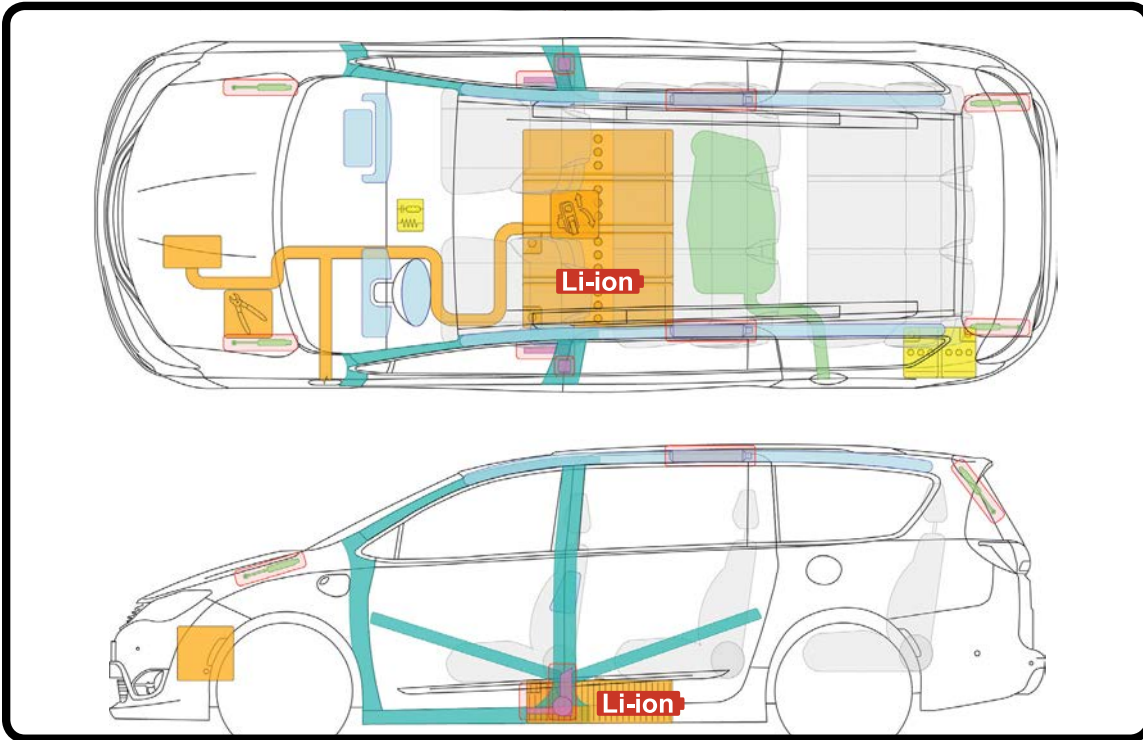

LEGEND		
Airbag	Bodywork Reinforcements	SRS Control Unit
Stored Gas Inflator	Support Cylinder for Hood	12V Battery
Seatbelt Tensioner or Pretensioner	Fuel Tank	High-Voltage Power Cable
High-Voltage Battery	Emergency Disconnect (Cut Cable)	Emergency Disconnect (Remove Plug)

SPECIAL CONCERNS

A PLUGGED IN VEHICLE

If the vehicle is plugged in for charging, you should first unplug it. If access to unplug the vehicle is unavailable, “remove charge power” from the vehicle (done by turning off the power to the charge station).



Vehicle Charging Plug

For towing and post-incident instructions, see the **POST-INCIDENT** section on page 20.



2009

HYBRID
TWO MODE HEMI



2009 DODGE DURANGO

VEHICLE INFORMATION

IMMOBILIZE VEHICLE

- 1. Chock the wheels.
- 2. Set parking brake. (foot pedal)
- 3. Place vehicle into park. (steering column)

DISABLE VEHICLE

Determine if vehicle ON by presence of READY indicator on speedometer or any reading on Hybrid Economy gauge (right of speedometer).

PRIMARY PROCEDURE

- 1. If ON, turn the vehicle's ignition off (key, steering column). Remove key.
- 2. Disconnect or cut the 12V battery negative cable. The 12V battery is located beneath the vehicle and is difficult to access directly. There is a 12V battery low-voltage disconnect that can be accessed in the engine compartment (adjacent to the air cleaner on the driver's side of the engine).



12V Battery Disconnect

ALTERNATE PROCEDURE





Remove the high voltage service disconnect located on driver's side front of high voltage battery (under second row seat).

WARNING: Removing the service disconnect alone does not disable the 12V system, and therefore will not disable the airbag and SRS system. In order to disable the airbag system, cut or disconnect the 12V battery negative cable.



HV System Disconnect

WARNINGS

-  NEVER cut, breach, or touch high voltage components or cabling. Doing so could result in serious injury or death.
-  If an automatic shut-off is triggered by a crash, the high voltage system should be de-energized within 5 seconds. If manually shut-off, de-energizing the high voltage system capacitors could take up to 5 minutes. Always treat the high voltage system as if it is energized. The high voltage battery will remain energized regardless of shutdown.
-  Disable 12V power to shut down airbag system. Even if airbags have deployed, they may be capable of a second deployment.
-  Lack of engine noise does not mean vehicle is OFF. Silent movement or instant restart capability exists until vehicle is fully shut down.

HEV



2009

HYBRID
TWO MODE HEMI









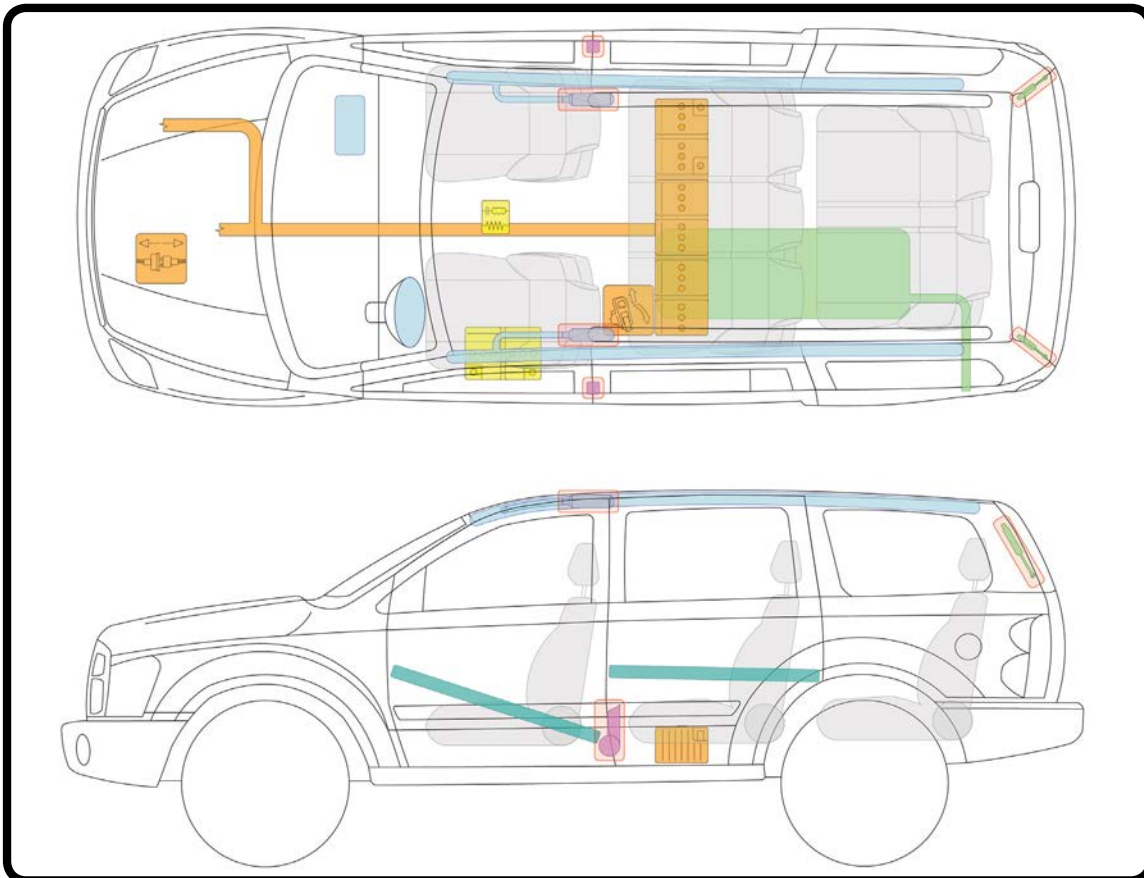

DODGE

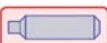
DODGE DURANGO

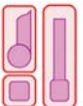
(continued) **EXTRICATION INFORMATION**

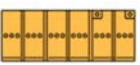

LEGEND		
 Airbag	 Bodywork Reinforcements	 SRS Control Unit
 Stored Gas Inflator	 Support Cylinder for Hood	 12V Battery
 Seatbelt Tensioner or Pretensioner	 Fuel Tank	 High-Voltage Power Cable
 High-Voltage Battery	 Emergency Disconnect (Remove Plug)	 Emergency Disconnect (Disconnect Plug)

For towing and post-incident instructions, see the **POST-INCIDENT** section on page 20.





VEHICLE INFORMATION

IMMOBILIZE VEHICLE

1. **Chock the wheels.**
2. **Set parking brake.** (foot pedal)
3. **Place vehicle into park.** (push-button shifter)

DISABLE VEHICLE

Determine if vehicle is ON by the illumination of the motion enable light  or the instrument cluster  showing a charge.

PRIMARY PROCEDURE

1. Turn the ignition key to the OFF position and remove key.
2. Engage emergency shutdown switch on dash.
3. Disconnect the crash sensor (under hood, on cabin firewall) by pressing the lock release and then pulling down to remove.
4. Disconnect the negative cable on the 12V battery (externally mounted under the cab on the driver's side).



Emergency Shutdown

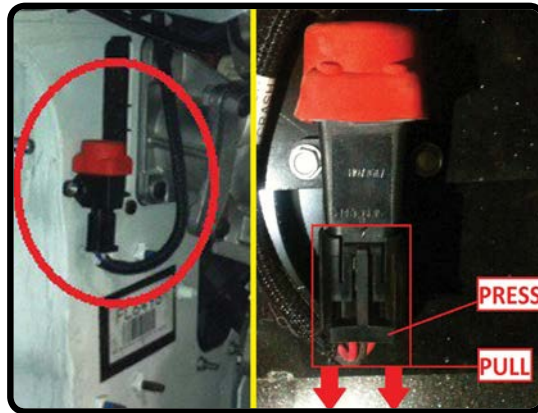

Crash Sensor Disconnect

ALTERNATE PROCEDURE

(if Primary Procedure fails to shut down HV system)





1. Remove both service disconnects from the side battery packs (under vehicle near the middle on both sides, at the rear of the battery pack).
2. Disconnect the negative cable on the 12V battery (externally mounted under the cab on the driver's side).



HV Disconnect

NOTE: Only one service disconnect needs to be removed in order to fully disconnect the HV system, but it is recommended that both be removed if possible.

WARNINGS

-  NEVER cut, breach, or touch high voltage components or cabling. Doing so could result in serious injury or death.
-  Always make sure that the high voltage system is shut down before disconnecting the 12V battery. Not doing so may result in serious injury or death from electrical shock.
-  When shutting down the high voltage system wait at least 1 minute for complete discharge of the high voltage capacitor.
-  This vehicle does not have an internal combustion engine. Lack of engine noise does not mean vehicle is OFF. Silent movement capability exists until vehicle is fully shut down.

ELECTRIC VEHICLES INTERNATIONAL

EV1

M2-MD



M2-MD

ELECTRIC VEHICLES INTERNATIONAL

(continued) **EXTRICATION INFORMATION**

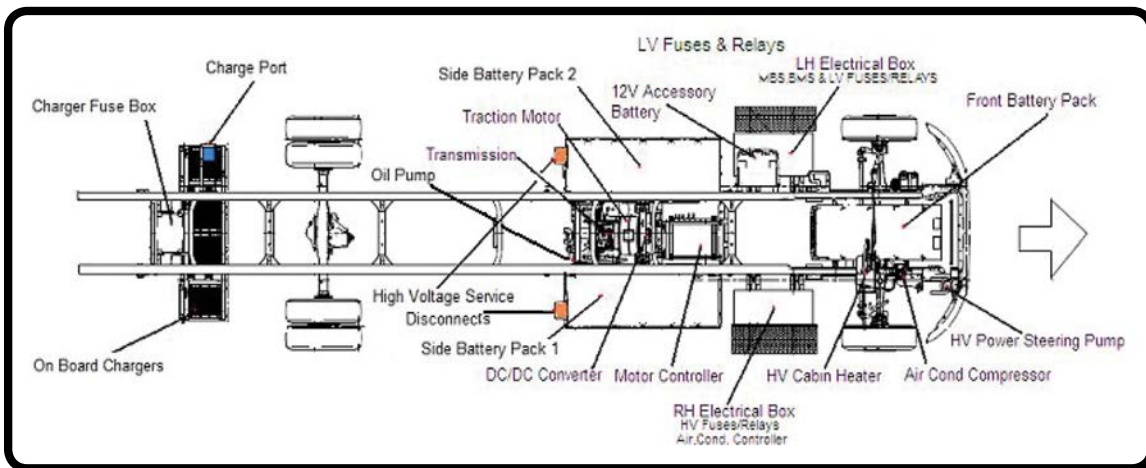

For towing and post-incident instructions, see the **POST-INCIDENT** section on page 20.



VEHICLE INFORMATION

IMMOBILIZE VEHICLE

1. Chock the wheels.
2. Set parking brake. (foot pedal)
3. Place vehicle into park. (push-button shifter)

DISABLE VEHICLE

Determine if vehicle is ON by the illumination of the motion enable light



or the instrument cluster  showing a charge.



EMER Shutdown

PRIMARY PROCEDURE

1. Turn the ignition key to the OFF position and remove key.



(Key Fob: Press engine stop button dashboard) and remove key fob and keep it at least 16 feet (5 meters) from vehicle.

2. Engage emergency shutdown switch (dash).
3. Disconnect the crash sensor (under hood, on cabin firewall behind radiator reservoir) by pressing the lock release and then pulling down to remove.
4. Disconnect the negative cable on the 12V battery (under steps on passenger side).

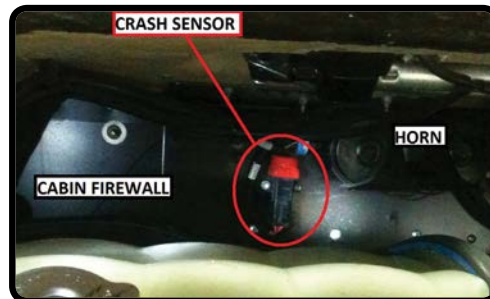

Crash Sensor Location



Sensor Disconnect



HV Disconnect

ALTERNATE PROCEDURE

(if Primary fails to shut down HV system)

1. Remove both service disconnects from the side battery packs (under vehicle near the middle on both sides, at the rear of the battery pack).

2. Disconnect the negative cable on the 12V battery (under steps on passenger side).

NOTE: Only one service disconnect needs to be removed in order to fully disconnect the HV system, but it is recommended that both be removed if possible.

WARNINGS



NEVER cut, breach, or touch high voltage components or cabling. Doing so could result in serious injury or death.



Always make sure that the high voltage system is shut down before disconnecting the 12V battery. Not doing so may result in serious injury or death from electrical shock.



When shutting down the high voltage system wait at least 1 minute for complete discharge of the high voltage capacitor.



This vehicle does not have an internal combustion engine. Lack of engine noise does not mean vehicle is OFF. Silent movement capability exists until vehicle is fully shut down.

ELECTRIC VEHICLES INTERNATIONAL

EV1

P70E / P10XE



ELECTRIC VEHICLES INTERNATIONAL
P70E / P10XE

(continued) **EXTRICATION INFORMATION**

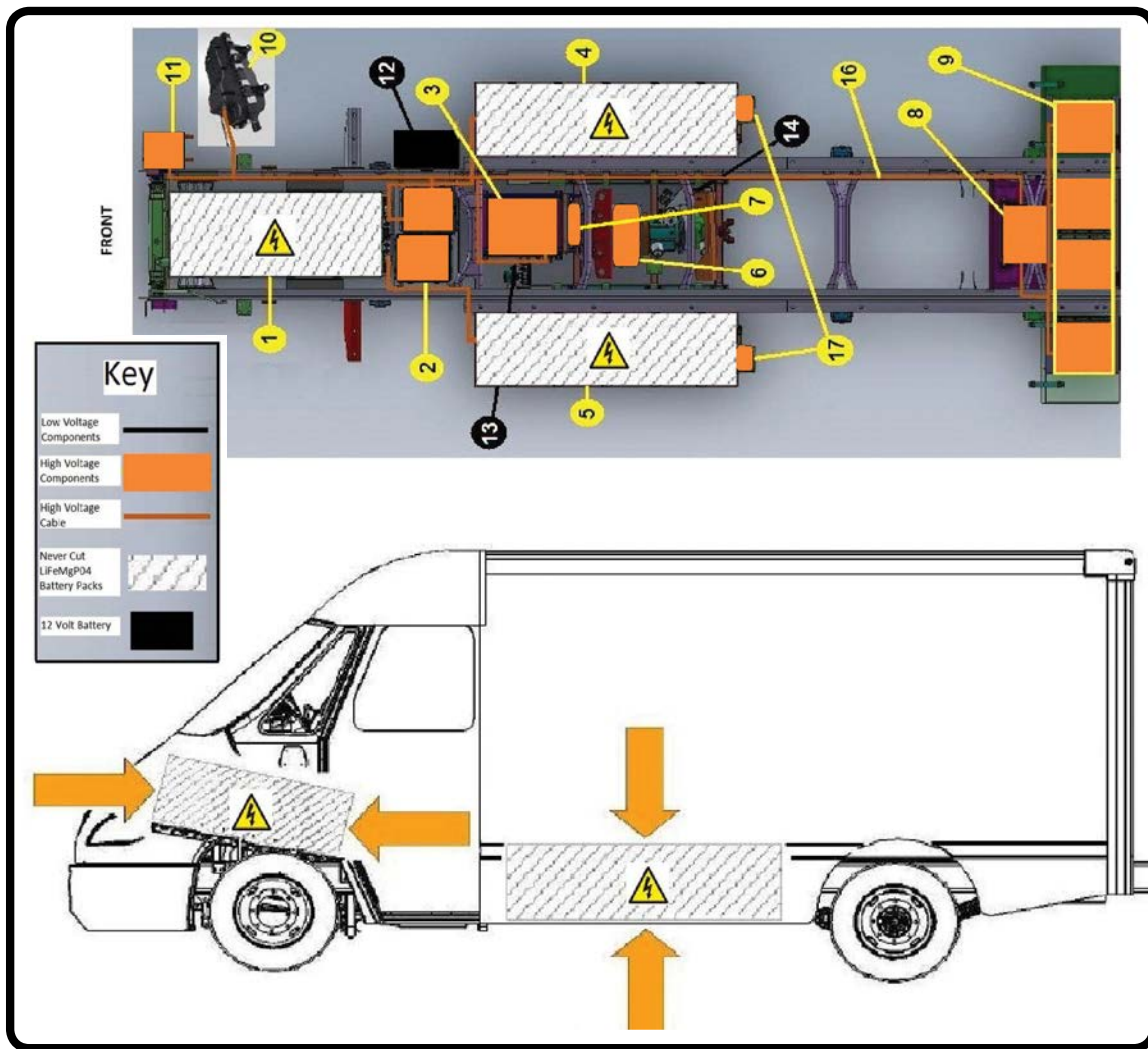

For towing and post-incident instructions, see the **POST-INCIDENT** section on page 20.



2013-16

☆ZFF76ZHB000198002☆
HYBRID VEHICLE



VEHICLE INFORMATION

IMMOBILIZE VEHICLE

- 1. **Chock the wheels.**
- 2. **Set parking brake.**
(pull lever, on dashboard left of steering wheel)
- 3. **Place vehicle into park.**
(center console)

DISABLE VEHICLE

PRIMARY PROCEDURE

- 1. Turn the ignition switch to OFF. Remove key.
- 2. Open engine compartment. Pull lever under the rear driver side door jamb.
- 3. Remove cosmetic engine cover.
- 4. Cut 12V battery positive cable (near Hybrid Power Unit) in two marked positions and remove section.
- 5. Cut 12V battery negative cable (engine compartment, left side) in two marked positions and remove section.



Turn Key to OFF



Hood Release



Remove Cosmetic Engine Cover





Cut 12V Battery Positive Cable As Marked



Cut 12V Battery Negative Cable As Marked

WARNINGS

-  NEVER cut, breach, or touch high voltage components or cabling. Doing so could result in serious injury or death.
-  The high voltage system may remain powered for up to 30 seconds after vehicle is shut off.
-  Lack of engine noise does not mean vehicle is OFF. Silent movement or instant restart capability exists until vehicle is fully shut down.

Ferrari

Laferrari

FERRARI









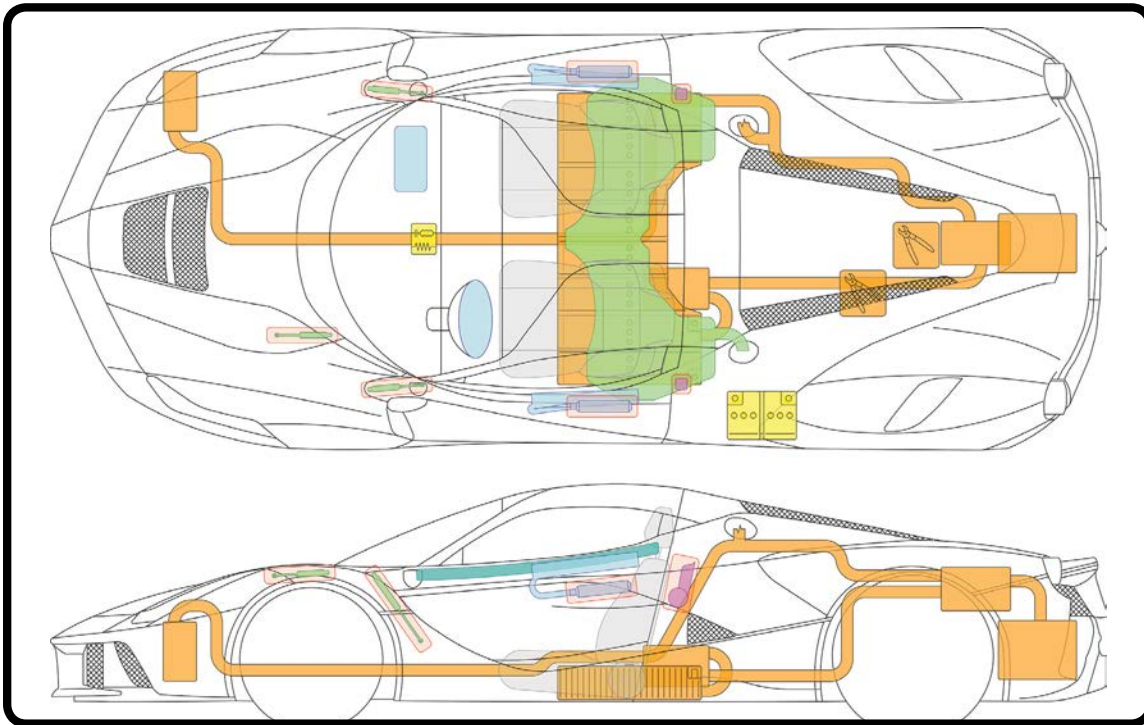



2013-16



(continued) **EXTRICATION INFORMATION**

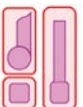
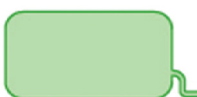

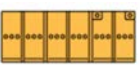
LEGEND

 Airbag	 Bodywork Reinforcements	 SRS Control Unit
 Stored Gas Inflator	 Support Cylinder for Hood	 12V Battery
 Seatbelt Tensioner or Pretensioner	 Fuel Tank	 High-Voltage Power Cable
 High-Voltage Battery	 Emergency Disconnect (Cut Cable)	

For towing and post-incident instructions, see the **POST-INCIDENT** section on page 20.



2013-18



VEHICLE INFORMATION

Li-ion

See pages 15, 22.

IMMOBILIZE VEHICLE

1. **Chock the wheels.**
2. **Set parking brake.**
(hand brake, center console)
3. **Place vehicle into park.**
(push-button, center console)

DISABLE VEHICLE

PRIMARY PROCEDURE

1. Turn the vehicle's ignition off (steering column, key). Remove key.
2. Remove cover on 12V battery (engine compartment).
3. Cut and remove a segment from the three cables attached to the negative terminal of the 12V battery.
4. Cut and remove a segment of each cable attached to the positive terminal of the 12V battery.

ALTERNATE PROCEDURE

1. Cut all cables attached to the 12V battery (engine compartment).
2. Locate the Manual Service Disconnect by removing the rear seat cushion.
3. Remove cover and then pull out the Manual Service Disconnect.

HIGH VOLTAGE MANUAL DISCONNECT

You can minimize potential for high voltage current flow by removing the Manual Service Disconnect from the high voltage battery (located underneath the rear seat cushion).



12V Battery Disconnect



Manual Service Disconnect (MSD)

WARNINGS

- NEVER cut, breach, or touch high voltage components or orange cabling. Doing so could result in serious injury or death.
- You must wait a minimum of 5 minutes for the HV System to discharge before working on the vehicle.
- Airbags and SRS may remain powered for up to 2 minutes after shutoff/disabling. Avoid breaching SRS components.
- This vehicle does not have an internal combustion engine. Lack of engine noise does not mean vehicle is OFF. Silent movement capability exists until vehicle is fully shut down.

FIAT



FIAT



2013-18



Li-ion (continued) **EXTRICATION INFORMATION**

See pages 15, 22.

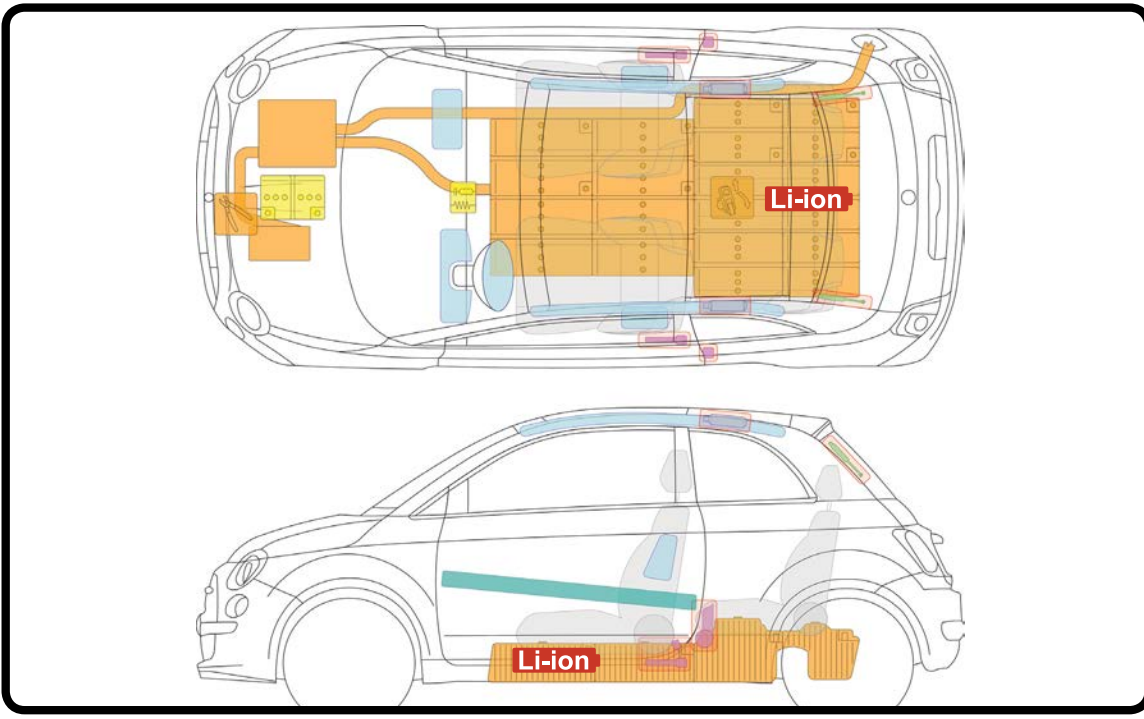

LEGEND			
	Airbag		Bodywork Reinforcements
	SRS Control Unit		12V Battery
	Stored Gas Inflator		Support Cylinder for Hood
	Seatbelt Tensioner or Pretensioner		High-Voltage Power Cable
	High-Voltage Battery		Emergency Disconnect (Remove Plug)
			Emergency Disconnect (Cut Cable)

SPECIAL CONCERNS

A PLUGGED IN VEHICLE

If the vehicle is plugged in for charging, you should first unplug it. If access to unplug the vehicle is unavailable, “remove charge power” from the vehicle (done by turning off the power to the charge station).



Vehicle Charging Plug

For towing and post-incident instructions, see the **POST-INCIDENT** section on page 20.



2012-13

EVER



FISKER

FISKER

VEHICLE INFORMATION

Li-ion

See pages 15, 22.

IMMOBILIZE VEHICLE

1. **Chock the wheels.**
2. **Set parking brake.**
(lower left-side of the steering column)
3. **Place vehicle into park.**
(center console)

DISABLE VEHICLE

PRIMARY PROCEDURE

1. If ON, depress the brake and press the Start/Stop button. If the vehicle will NOT turn off, then press the Start/Stop Button 3 TIMES rapidly to force the vehicle to power down. Remove key.
2. Disconnect the negative cable from the 12V battery which will disable the high-voltage system (engine compartment, passenger's side).
3. Cut the power cable by the APM which is identified with an emergency cut sticker (engine compartment, driver's side).
4. Remove the Manual Service Disconnect (MSD) located under the driver-side rear seat. Open the access cover by sliding out the locking pin. Remove the MSD by pressing the tab and lifting the handle. Remove the MSD completely.

NOTE: Remove the MSD only after the vehicle is completely shut down.



12V Battery Disconnect









APM Disconnect



Manual Service Disconnect (MSD)

WARNINGS

-  NEVER cut, breach, or touch high voltage components or orange cabling. Doing so could result in serious injury or death.
-  You must wait a minimum of 5 minutes for the HV System to discharge before working on the vehicle.
-  If the vehicle is submerged, do not touch high voltage cabling or components until you are SURE the high-voltage battery is fully discharged (when fizzing/bubbling stops).
-  Remove the Manual Service Disconnect only after the vehicle is completely shut down.
-  In the event of a fire involving a charging station, reference the **FIRE** portion of this guide, and treat it as an energized electrical fire until power to the charger can be shut down.
-  Lack of engine noise does not mean vehicle is OFF. Silent movement or instant restart capability exists until vehicle is fully shut down.

KARMA



2012-13



FISKER

KARMA

Li-ion (continued) **EXTRICATION INFORMATION**

See pages 15, 22.

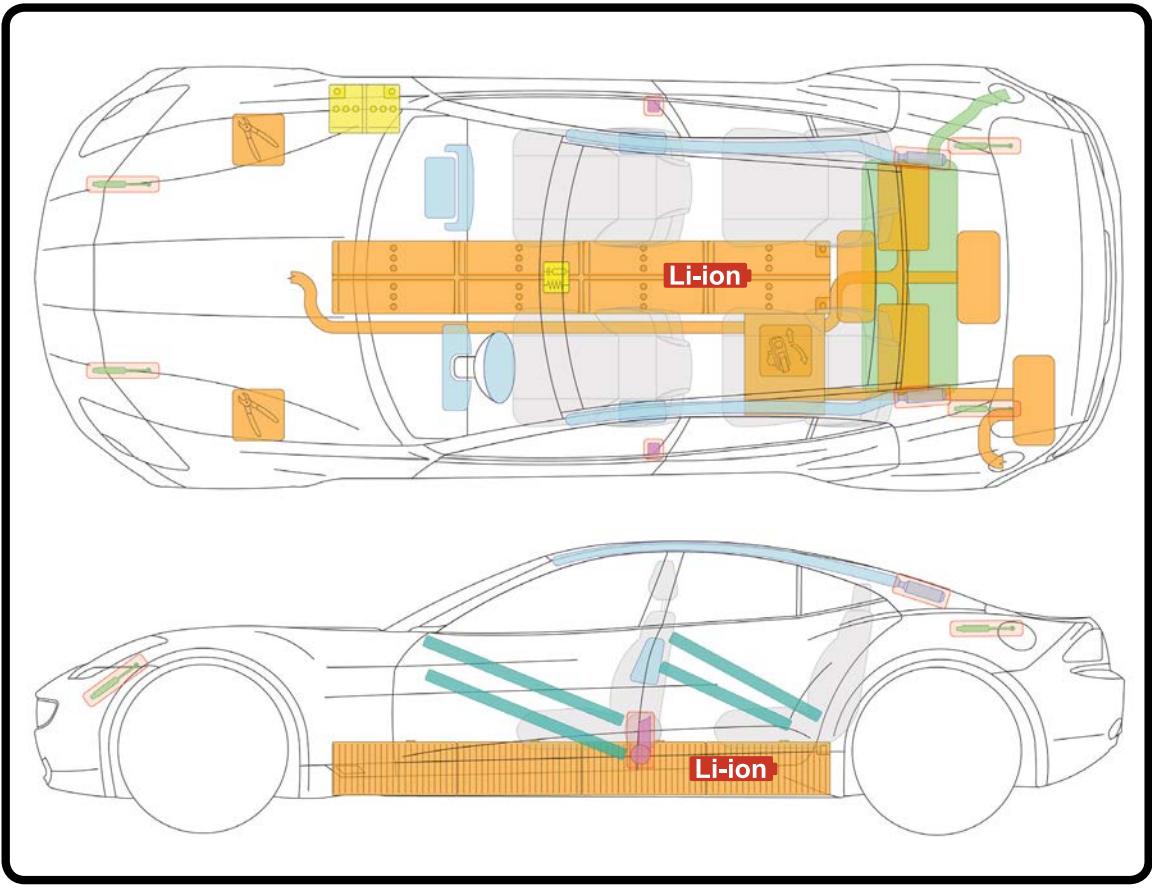

LEGEND		
Airbag	Bodywork Reinforcements	SRS Control Unit
Stored Gas Inflator	Support Cylinder for Hood	12V Battery
Seatbelt Tensioner or Pretensioner	Fuel Tank	High-Voltage Power Cable
High-Voltage Battery	Emergency Disconnect (Remove Plug)	Emergency Disconnect (Cut Cable)

For towing and post-incident instructions, see the **POST-INCIDENT** section on page 20.

FISKER



2013-18



VEHICLE INFORMATION

Li-ion

See pages 15, 22.

IMMOBILIZE VEHICLE

1. **Chock the wheels.**
2. **Set parking brake.**
(hand brake, center console)
3. **Place vehicle into park.**
(center console)

DISABLE VEHICLE

Determine if vehicle is ON by illumination of color LCD screens on both sides of speedometer.

PRIMARY PROCEDURE

1. If ON, turn the vehicle's ignition off (Key/Button on dash). Remove key.
2. Disconnect the negative cable from the 12V battery (trunk).

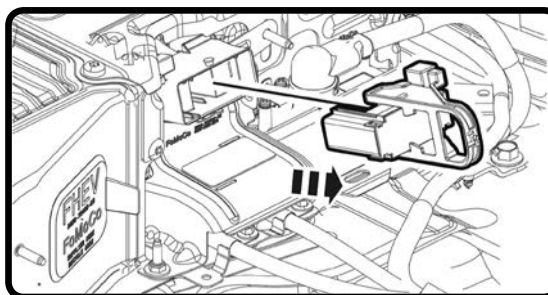

HV Service Disconnect

ALTERNATE PROCEDURE

1. Disconnect the negative cable from the 12V battery (trunk).
2. HV service disconnect behind the rear seat back on the driver side. Fold the rear seat back down and remove the cover to access.
3. Pull lever handle outward to disengage interlock. Rotate the lever to horizontal. Remove the HV service disconnect completely.

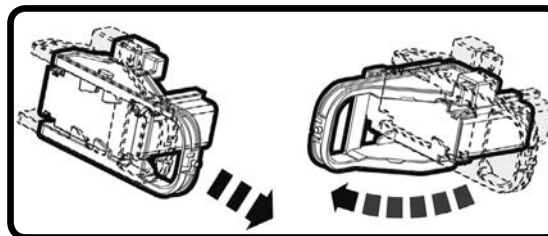

HV Service Disconnect Detail

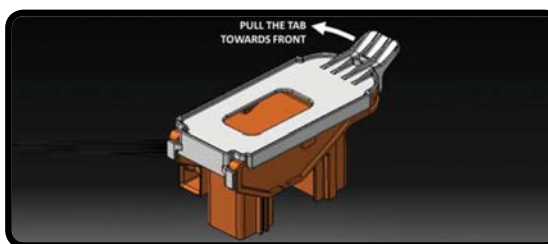

2014 and Later Year Vehicles Only

WARNINGS

- NEVER cut, breach, or touch high voltage components or cabling. Doing so could result in serious injury or death.
- If the vehicle has exposed cables, make sure to wear high-voltage rubber gloves and other protective clothing.
- If the vehicle is equipped with remote start, high-voltage may be present in the system if the ignition is off.
- If the vehicle is submerged, do not touch high voltage cabling or components until you are SURE the high-voltage battery is fully discharged (when fizzing/bubbling stops).
- Lack of engine noise does not mean vehicle is OFF. Silent movement or instant restart capability exists until vehicle is fully shut down.

Ford

FORD

MAX

HEV



2013-18



FORD

C-MAX

Li-ion (continued) **EXTRICATION INFORMATION**

See pages 15, 22.

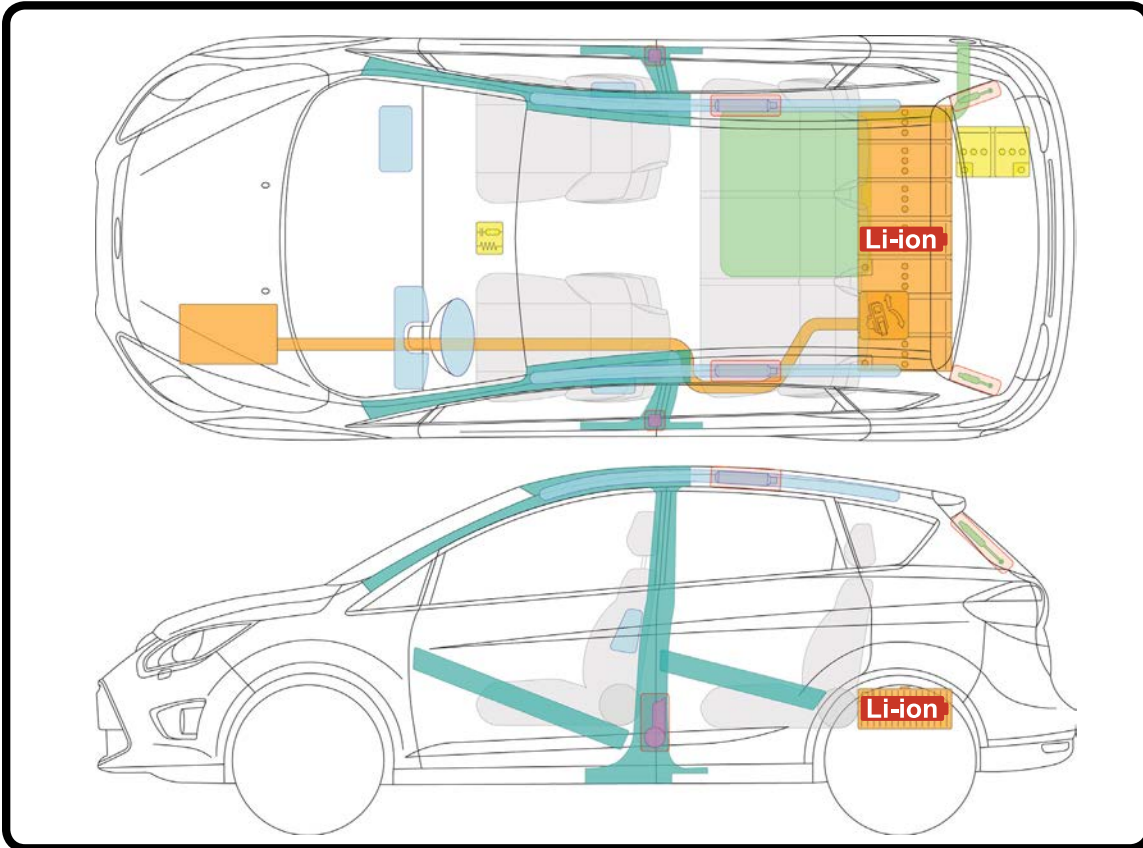

LEGEND		
Airbag	Bodywork Reinforcements	SRS Control Unit
Stored Gas Inflator	Support Cylinder for Hood	12V Battery
Seatbelt Tensioner or Pretensioner	Fuel Tank	High-Voltage Power Cable
High-Voltage Battery	Emergency Disconnect (Remove Plug)	

SUBMERSION

Ford recommends that a submerged vehicle not be removed from water until the high voltage battery is completely discharged (when microbubbling has completely stopped).

For towing and post-incident instructions, see the **POST-INCIDENT** section on page 20.

Ford



2013-18



VEHICLE INFORMATION

Li-ion

See pages 15, 22.

IMMOBILIZE VEHICLE

1. **Chock the wheels.**
2. **Set parking brake.**
(hand brake, center console)
3. **Place vehicle into park.**
(center console)

DISABLE VEHICLE

Determine if vehicle is ON by illumination of color LCD screens on both sides of speedometer.

PRIMARY PROCEDURE

1. If ON, turn the vehicle's ignition off (Key/Button on dash). Remove key.
2. Disconnect the negative cable from the 12V battery (trunk).

ALTERNATE PROCEDURE

1. Disconnect the negative cable from the 12V battery (trunk).
2. HV service disconnect behind the rear seat back on the passenger side. Fold the rear seat back down and remove the cover to access.
3. Pull lever handle outward to disengage interlock. Rotate the lever to horizontal. Remove the HV service disconnect completely.

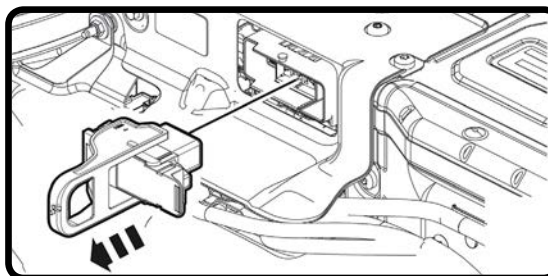

HV Service Disconnect

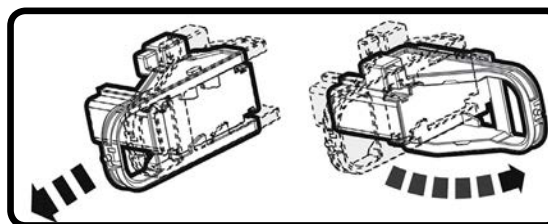

HV Service Disconnect Detail

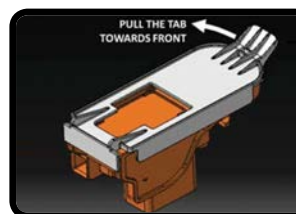

2014 and Later Year Vehicles Only

WARNINGS

- NEVER cut, breach, or touch high voltage components or cabling. Doing so could result in serious injury or death.
- If the vehicle has exposed cables, make sure to wear high-voltage rubber gloves and other protective clothing.
- If the vehicle is equipped with remote start, high-voltage may be present in the system if the ignition is off.
- ENERGI vehicles, when plugged in for charging may have high-voltage present in the system if the ignition is off.
- If the vehicle is submerged, do not touch high voltage cabling or components until you are SURE the high-voltage battery is fully discharged (when fizzing/bubbling stops).
- In the event of a fire involving a charging station, reference the **FIRE** portion of this guide, and treat it as an energized electrical fire until power to the charger can be shut down.
- Lack of engine noise does not mean vehicle is OFF. Silent movement or instant restart capability exists until vehicle is fully shut down.

Ford

FORD

MAX

ENERGI



2013-18



FORD

C-MAX ENERGI

Li-ion (continued) **EXTRICATION INFORMATION**

See pages 15, 22.

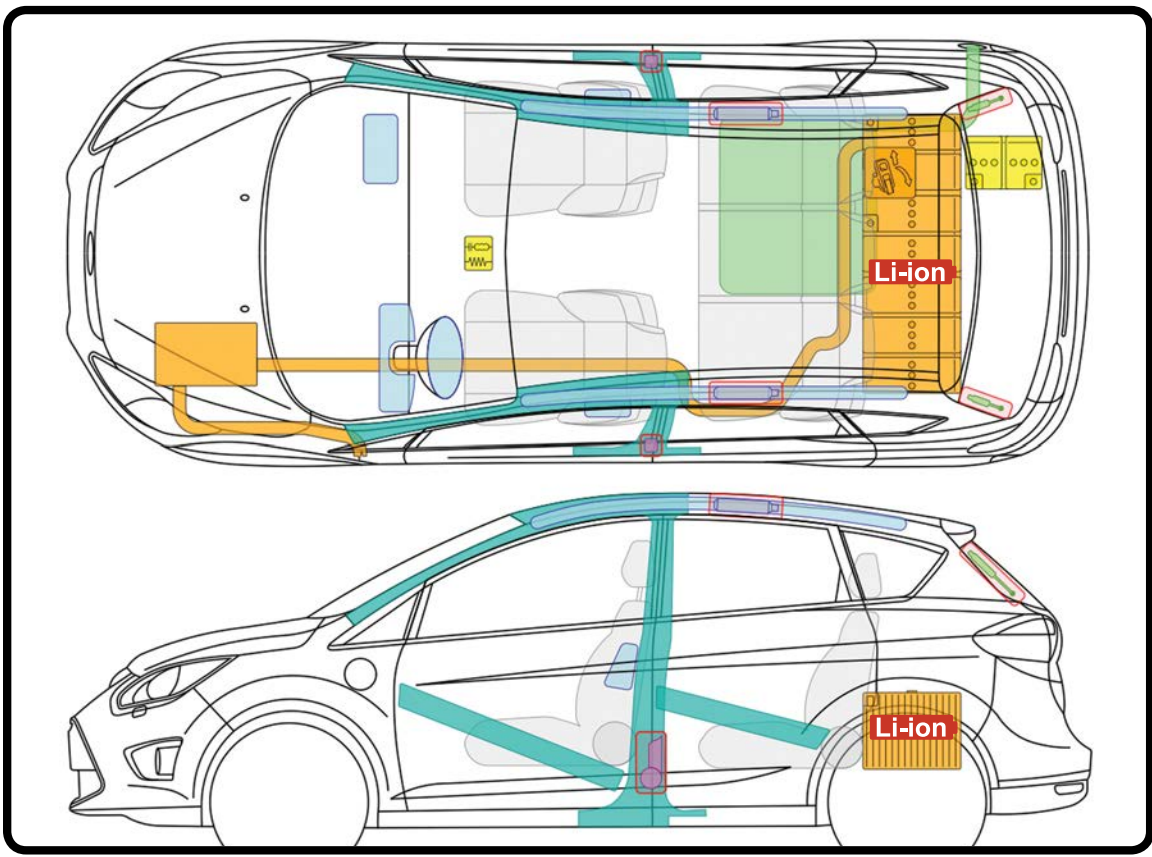

LEGEND		
Airbag	Bodywork Reinforcements	SRS Control Unit
Stored Gas Inflator	Support Cylinder for Hood	12V Battery
Seatbelt Tensioner or Pretensioner	Fuel Tank	High-Voltage Power Cable
High-Voltage Battery	Emergency Disconnect (Remove Plug)	

SUBMERSION

Ford recommends that a submerged vehicle not be removed from water until the high voltage battery is completely discharged (when microbubbling has completely stopped).

For towing and post-incident instructions, see the **POST-INCIDENT** section on page 20.

Ford



2005-07



VEHICLE INFORMATION

IMMOBILIZE VEHICLE

1. **Chock the wheels.**
2. **Set parking brake.**
(hand brake, center console)
3. **Place vehicle into park.**
(center console)

DISABLE VEHICLE

Determine if vehicle is ON by the presence of a small green vehicle icon on the right side of the instrument panel. Also, if the tachometer is on the Green EV bar, the vehicle is in its READY mode.

PRIMARY PROCEDURE

1. If ON, turn the vehicle's ignition off (key on steering column). Remove key.
2. Disconnect the negative cable from the 12V battery (engine compartment, driver's side).

ALTERNATE PROCEDURE

1. Disconnect the negative cable from the 12V battery.
2. Remove the high voltage service disconnect (located on top of the high-voltage battery in the cargo area) by turning it counterclockwise to the UNLOCK position. Then place the switch in the SERVICE/SHIPPING position.







HV Battery Pack

HV Service Disconnect Switch



High-Voltage Service Disconnect Switch Shown in LOCK position

WARNINGS

-  NEVER cut, breach, or touch high voltage components or cabling. Doing so could result in serious injury or death.
-  If the vehicle has exposed cables, make sure to wear high-voltage rubber gloves and other protective clothing.
-  If the vehicle is submerged, do not touch high voltage cabling or components until you are SURE the high-voltage battery is fully discharged (when fizzing/bubbling stops).
-  Lack of engine noise does not mean vehicle is OFF. Silent movement or instant restart capability exists until vehicle is fully shut down.

Ford

FORD

ESCAPE

HEV



2005-07









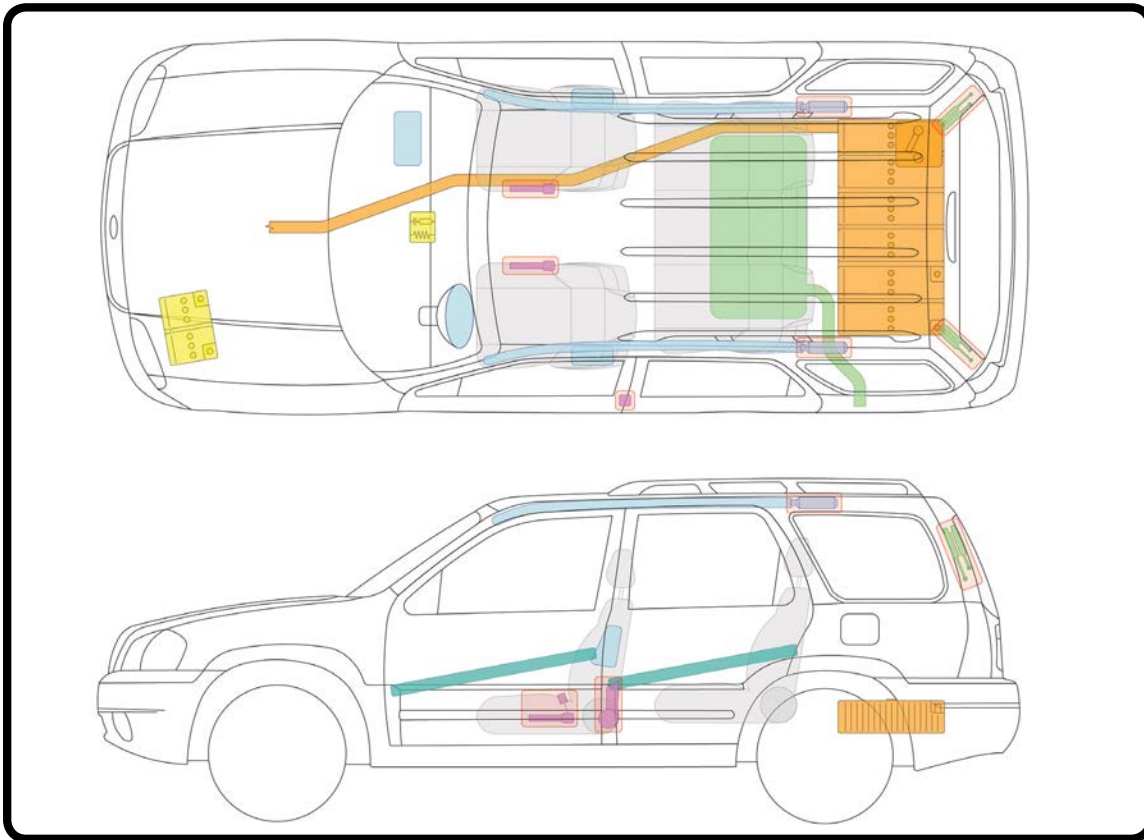



FORD

ESCAPE

(continued) **EXTRICATION INFORMATION**

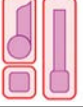

LEGEND

 Airbag	 Bodywork Reinforcements	 SRS Control Unit
 Stored Gas Inflator	 Support Cylinder for Hood	 12V Battery
 Seatbelt Tensioner or Pretensioner	 Fuel Tank	 High-Voltage Power Cable
 High-Voltage Battery	 Emergency Disconnect (Switch Off)	

SUBMERSION

Ford recommends that a submerged vehicle not be removed from water until the high voltage battery is completely discharged (when microbubbling has completely stopped).

For towing and post-incident instructions, see the **POST-INCIDENT** section on page 20.

Ford



2008-12



VEHICLE INFORMATION

IMMOBILIZE VEHICLE

- 1. Chock the wheels.
- 2. Set parking brake. (foot pedal)
- 3. Place vehicle into park. (center console)

DISABLE VEHICLE

Determine if vehicle is ON by the presence of a small green vehicle icon on the right side of the instrument panel. Also, if the tachometer is on the Green EV bar, the vehicle is in its READY mode.

PRIMARY PROCEDURE

- 1. If ON, turn the vehicle's ignition off (key on steering column). Remove key.
- 2. Disconnect the negative cable from the 12V battery (engine compartment, driver's side).

ALTERNATE PROCEDURE

- 1. Disconnect the negative cable from the 12V battery.
- 2. Remove the high voltage service disconnect (located on top of the high-voltage battery in the cargo area) by turning it counterclockwise to the UNLOCK position. Then place the switch in the SERVICE/SHIPPING position.





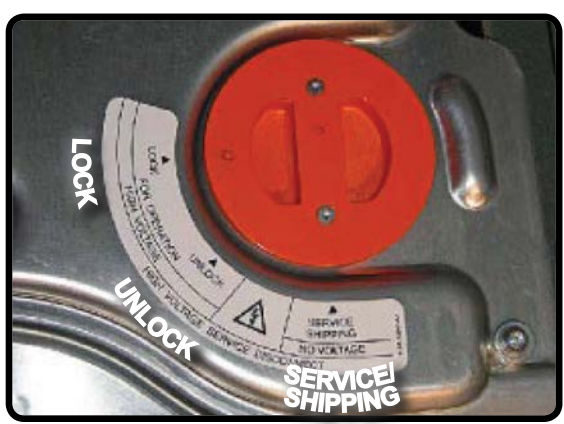

HV Battery Pack

HV Service Disconnect Switch



High-Voltage Service Disconnect Switch Shown in LOCK position

WARNINGS

-  NEVER cut, breach, or touch high voltage components or cabling. Doing so could result in serious injury or death.
-  If the vehicle has exposed cables, make sure to wear high-voltage rubber gloves and other protective clothing.
-  If the vehicle is submerged, do not touch high voltage cabling or components until you are SURE the high-voltage battery is fully discharged (when fizzing/bubbling stops).
-  Lack of engine noise does not mean vehicle is OFF. Silent movement or instant restart capability exists until vehicle is fully shut down.

Ford

FORD

ESCAPE

HEV



2008-12









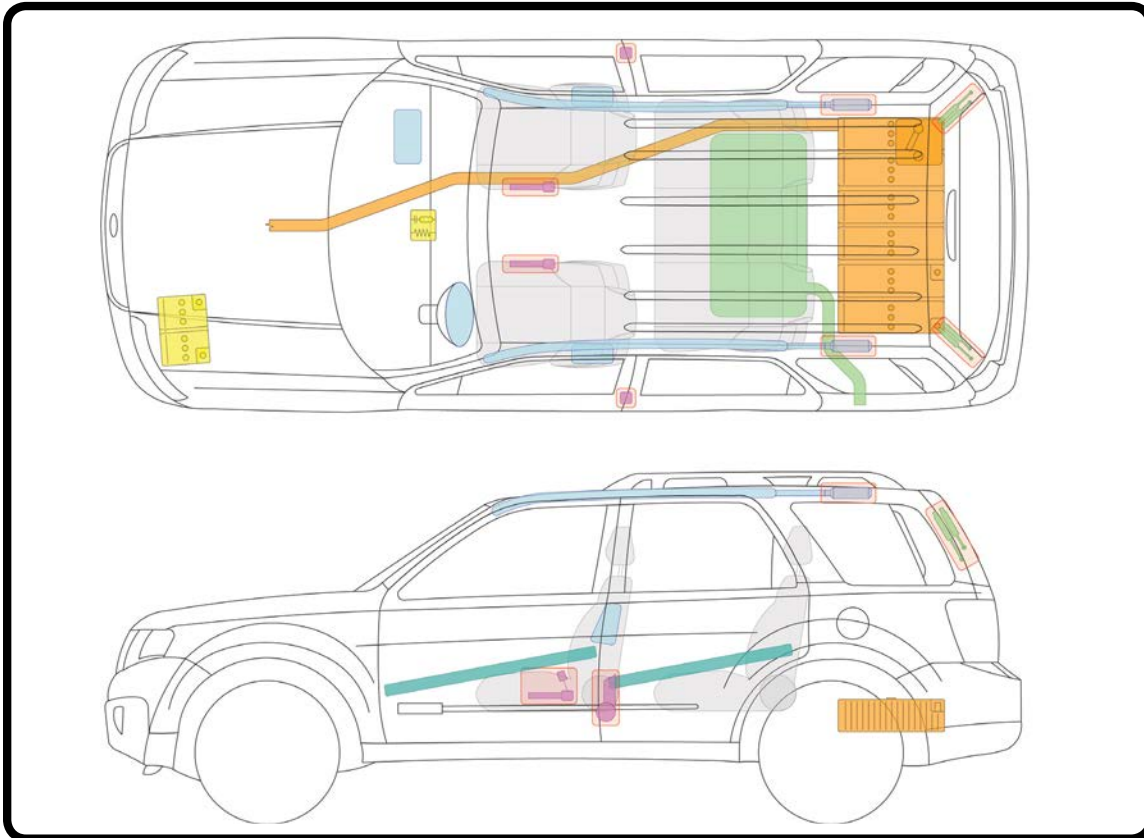

FORD

ESCAPE

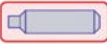
(continued) **EXTRICATION INFORMATION**

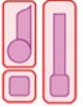

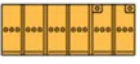
LEGEND

 Airbag	 Bodywork Reinforcements	 SRS Control Unit
 Stored Gas Inflator	 Support Cylinder for Hood	 12V Battery
 Seatbelt Tensioner or Pretensioner	 Fuel Tank	 High-Voltage Power Cable
 High-Voltage Battery	 Emergency Disconnect (Switch Off)	

SUBMERSION

Ford recommends that a submerged vehicle not be removed from water until the high voltage battery is completely discharged (when microbubbling has completely stopped).

For towing and post-incident instructions, see the **POST-INCIDENT** section on page 20.

Ford



2012-18



ELECTRIC

VEHICLE INFORMATION

Li-ion
See pages 15, 22.

IMMOBILIZE VEHICLE

- 1. **Chock the wheels.**
- 2. **Set parking brake.**
(hand brake, center console)
- 3. **Place vehicle into park.**
(center console)

DISABLE VEHICLE

PRIMARY PROCEDURE

- 1. If ON, turn the vehicle's ignition off (key on steering column).
- 2. If equipped with a proximity key, remove key and keep it at least 16 feet from the vehicle.
- 3. Disconnect the negative cable from the 12V battery (engine compartment).



Access Cover Behind Rear Seats

ALTERNATE PROCEDURE

- 1. Disconnect the negative cable from the 12V battery (engine compartment).
- 2. Locate and push the rear seat backrest latch release levers at the top of the seatback.
- 3. Remove the access cover to the upper battery service disconnect.
- 4. Depress the release tab at the top and rotate the release handle down approximately 45 degrees.
- 5. Depress the release tab again, and rotate the handle another 45 degrees. Pull out on the handle to fully remove the upper service disconnect.
- 6. Remove the lower battery service connect in the same manner (passenger side of the vehicle near the rear tire).





Remove Upper Service Disconnect Fully



Remove Lower Service Disconnect Fully

WARNINGS (continued on the next page)

-  NEVER cut, breach, or touch high voltage components or cabling. Doing so could result in serious injury or death.
-  If the vehicle has exposed cables, make sure to wear high-voltage rubber gloves and other protective clothing.
-  If the vehicle is submerged, do not touch high voltage cabling or components until you are SURE the high-voltage battery is fully discharged (when fizzing/bubbling stops).

Ford

FORD

FOCUS

ELECTRIC



2012-18



FORD

E-ELECTRIC

FOCUS



Li-ion (continued) **EXTRICATION INFORMATION**

See pages 15, 22.

WARNINGS (continued)

- In the event of a fire involving a charging station, reference the **FIRE** portion of this guide, and treat it as an energized electrical fire until power to the charger can be shut down.
- This vehicle does not have an internal combustion engine. Lack of engine noise does not mean vehicle is OFF. Silent movement capability exists until vehicle is fully shut down.

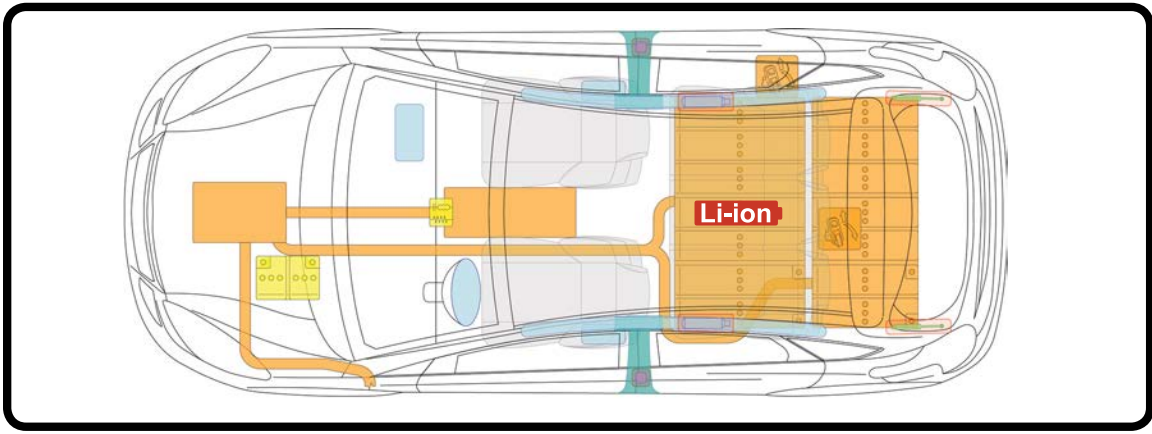

LEGEND		
Airbag	Bodywork Reinforcements	SRS Control Unit
Stored Gas Inflator	Support Cylinder for Hood	12V Battery
Seatbelt Tensioner or Pretensioner		High-Voltage Power Cable
High-Voltage Battery	Emergency Disconnect (Remove Plug)	

SPECIAL CONCERNS

A PLUGGED IN VEHICLE

If the vehicle is plugged in for charging, you should first unplug it. Starting in 2017 there is a manual override procedure to disengage the high-voltage charging cord in the event the safety latch doesn't release (see Ford's emergency response guide).

SUBMERSION

Ford recommends that a submerged vehicle not be removed from water until the high voltage battery is completely discharged (when microbubbling has completely stopped).

For towing and post-incident instructions, see the **POST-INCIDENT** section on page 20.



2010-12



VEHICLE INFORMATION

IMMOBILIZE VEHICLE

- 1. Chock the wheels.
- 2. Set parking brake. (foot pedal)
- 3. Place vehicle into park. (center console)

DISABLE VEHICLE

Determine if vehicle is ON by illumination of color LCD screens on both sides of speedometer.

PRIMARY PROCEDURE

- 1. If ON, turn the vehicle's ignition off (key on steering column). Remove key.
- 2. Disconnect the negative cable from the 12V battery (engine compartment, driver's side).

ALTERNATE PROCEDURE

- 1. Disconnect the negative cable from the 12V battery.
- 2. Locate the seat backrest latch release levers (2) in the rear storage area between the high-voltage battery and the body sheet metal.
- 3. Push the release lever toward the outboard side of the vehicle.
- 4. Lower rear seat to access disconnect from passenger cabin.
- 5. Remove the high voltage service disconnect.

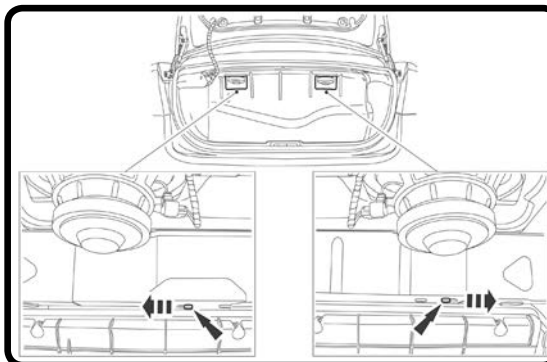



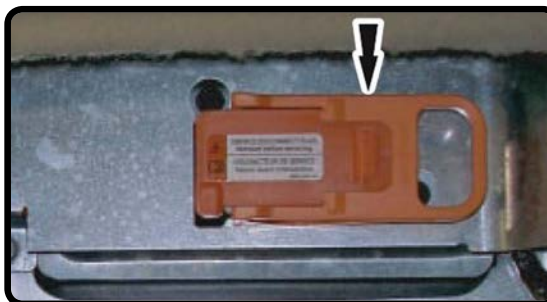

Seat Backrest Latch Releases



High-Voltage Disconnect

WARNINGS

-  NEVER cut, breach, or touch high voltage components or cabling. Doing so could result in serious injury or death.
-  If the vehicle has exposed cables, make sure to wear high-voltage rubber gloves and other protective clothing.
-  If the vehicle is submerged, do not touch high voltage cabling or components until you are SURE the high-voltage battery is fully discharged (when fizzing/bubbling stops).
-  Lack of engine noise does not mean vehicle is OFF. Silent movement or instant restart capability exists until vehicle is fully shut down.

Ford

FORD

FUSION

HEV



2010-12









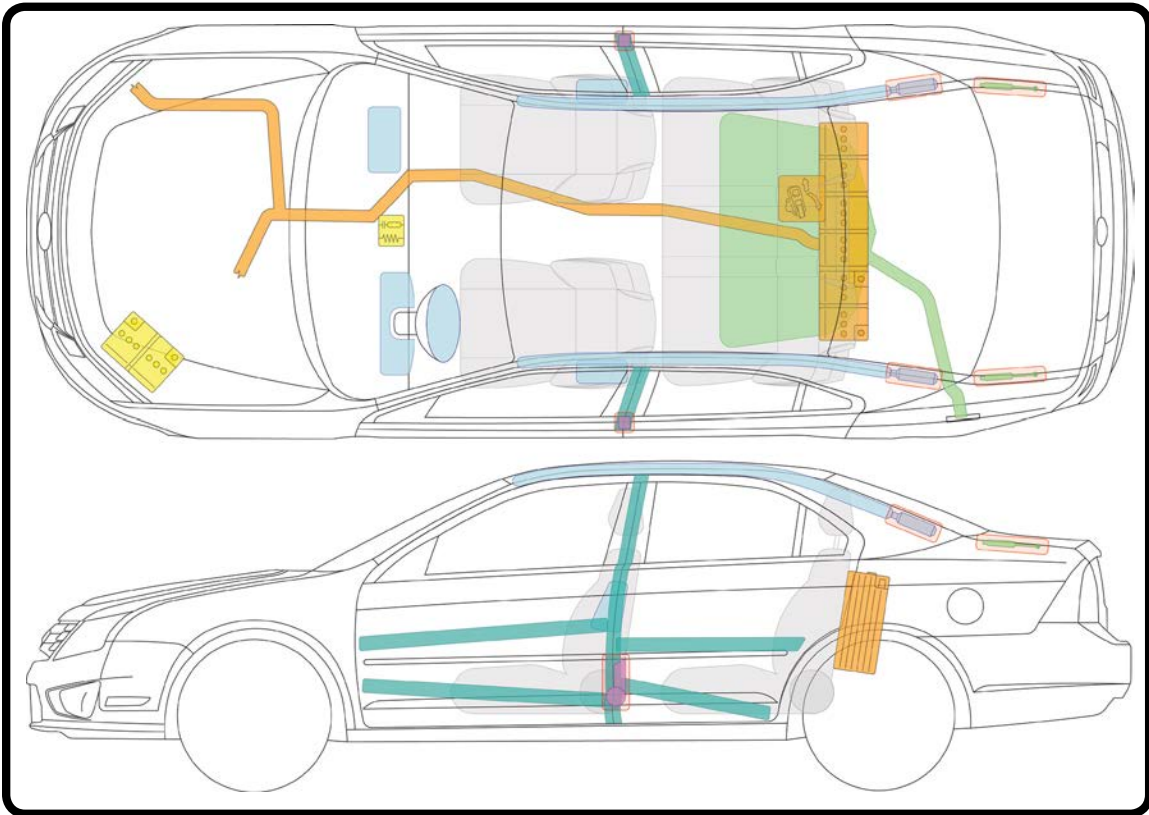

FORD

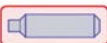
FUSION

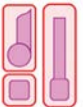
(continued) **EXTRICATION INFORMATION**



LEGEND		
 Airbag	 Bodywork Reinforcements	 SRS Control Unit
 Stored Gas Inflator	 Support Cylinder for Hood	 12V Battery
 Seatbelt Tensioner or Pretensioner	 Fuel Tank	 High-Voltage Power Cable
 High-Voltage Battery	 Emergency Disconnect (Remove Plug)	

SUBMERSION

Ford recommends that a submerged vehicle not be removed from water until the high voltage battery is completely discharged (when microbubbling has completely stopped).

For towing and post-incident instructions, see the **POST-INCIDENT** section on page 20.





2013-18



HYBRID

VEHICLE INFORMATION

Li-ion

See pages 15, 22.

IMMOBILIZE VEHICLE

- 1. Chock the wheels.
- 2. Set parking brake. (foot pedal)
- 3. Place vehicle into park. (center console)

DISABLE VEHICLE

Determine if vehicle is ON by illumination of color LCD screens on both sides of speedometer.

PRIMARY PROCEDURE

- 1. If ON, turn the vehicle's ignition off (Key/Button on dash). Remove key.
- 2. Disconnect the negative cable from the 12V battery (trunk, driver's side).

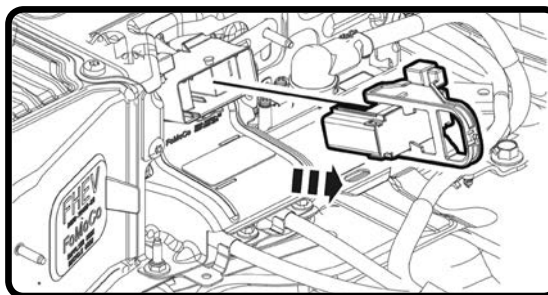

HV Service Disconnect

ALTERNATE PROCEDURE

- 1. Disconnect the negative cable from the 12V battery (trunk, driver's side).
- 2. HV service disconnect behind the rear seat back on the driver side. Fold the rear seat back down and remove the cover to access.
- 3. Pull lever handle outward to disengage interlock. Rotate the lever to horizontal. Remove the HV service disconnect completely.

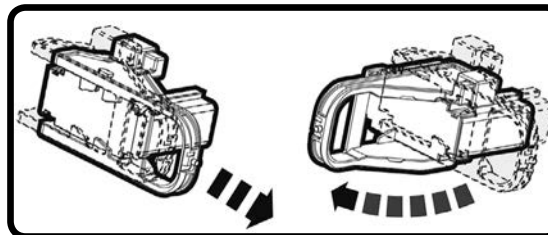

HV Service Disconnect Detail

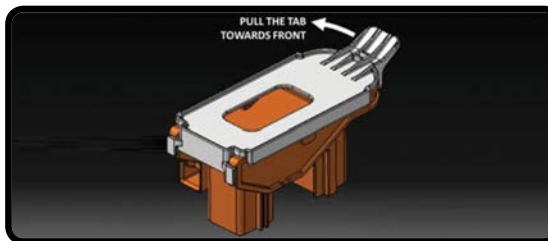

2014 and Later Year Vehicles Only

WARNINGS

- NEVER cut, breach, or touch high voltage components or cabling. Doing so could result in serious injury or death.
- If the vehicle has exposed cables, make sure to wear high-voltage rubber gloves and other protective clothing.
- If the vehicle is submerged, do not touch high voltage cabling or components until you are SURE the high-voltage battery is fully discharged (when fizzing/bubbling stops).
- If the vehicle is equipped with remote start, high-voltage may be present in the system if the ignition is off.
- Lack of engine noise does not mean vehicle is OFF. Silent movement or instant restart capability exists until vehicle is fully shut down.

Ford

FORD

FUSION

HEV



2013-18

HYBRID



FORD

FUSION

Li-ion (continued) **EXTRICATION INFORMATION**

See pages 15, 22.

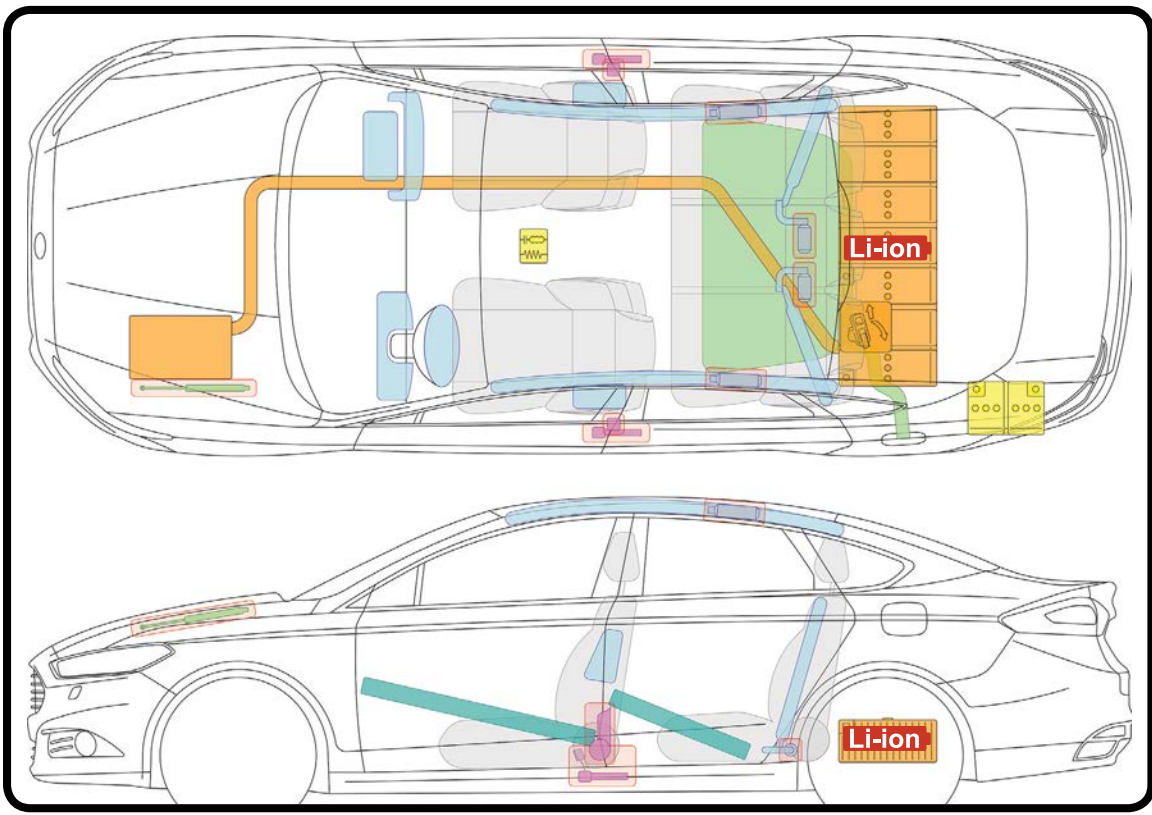

LEGEND		
Airbag	Bodywork Reinforcements	SRS Control Unit
Stored Gas Inflator	Support Cylinder for Hood	12V Battery
Seatbelt Tensioner or Pretensioner	Fuel Tank	High-Voltage Power Cable
High-Voltage Battery	Emergency Disconnect (Remove Plug)	

SUBMERSION

Ford recommends that a submerged vehicle not be removed from water until the high voltage battery is completely discharged (when microbubbling has completely stopped).

For towing and post-incident instructions, see the **POST-INCIDENT** section on page 20.





2013-18



VEHICLE INFORMATION

Li-ion

See pages 15, 22.

IMMOBILIZE VEHICLE

1. Chock the wheels.
2. Set parking brake. (foot pedal)
3. Place vehicle into park. (center console)

DISABLE VEHICLE

Determine if vehicle is ON by illumination of color LCD screens on both sides of speedometer.

PRIMARY PROCEDURE

1. If ON, turn the vehicle's ignition off (Key/Button on dash). Remove key.
2. Disconnect the negative cable from the 12V battery (trunk, driver's side).

ALTERNATE PROCEDURE

1. Disconnect the negative cable from the 12V battery (trunk, driver's side).
2. HV service disconnect behind the rear seat back on the passenger side. Fold the rear seat back down and remove the cover to access.
3. Pull lever handle outward to disengage interlock. Rotate the lever to horizontal. Remove the HV service disconnect completely.

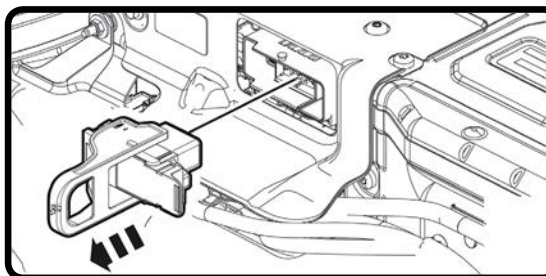

HV Service Disconnect

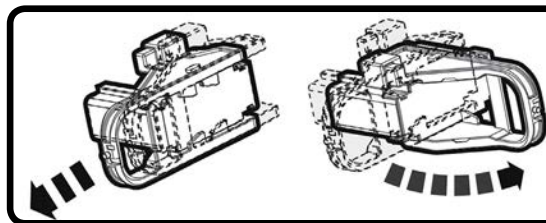

HV Service Disconnect Detail

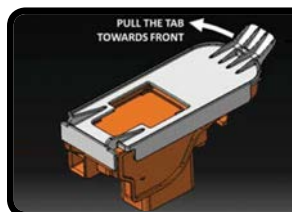

2014 and Later Year Vehicles Only

WARNINGS

- NEVER cut, breach, or touch high voltage components or cabling. Doing so could result in serious injury or death.
- If the vehicle has exposed cables, make sure to wear high-voltage rubber gloves and other protective clothing.
- If the vehicle is submerged, do not touch high voltage cabling or components until you are SURE the high-voltage battery is fully discharged (when fizzing/bubbling stops).
- If the vehicle is equipped with remote start, high-voltage may be present in the system if the ignition is off.
- ENERGI vehicles, when plugged in for charging may have high-voltage present in the system if the ignition is off.
- In the event of a fire involving a charging station, reference the FIRE portion of this guide, and treat it as an energized electrical fire until power to the charger can be shut down.
- Lack of engine noise does not mean vehicle is OFF. Silent movement or instant restart capability exists until vehicle is fully shut down.

Ford

FORD

PLUG-IN HYBRID

ENERGI



2013-18



FORD



Li-ion (continued) **EXTRICATION INFORMATION**

See pages 15, 22.

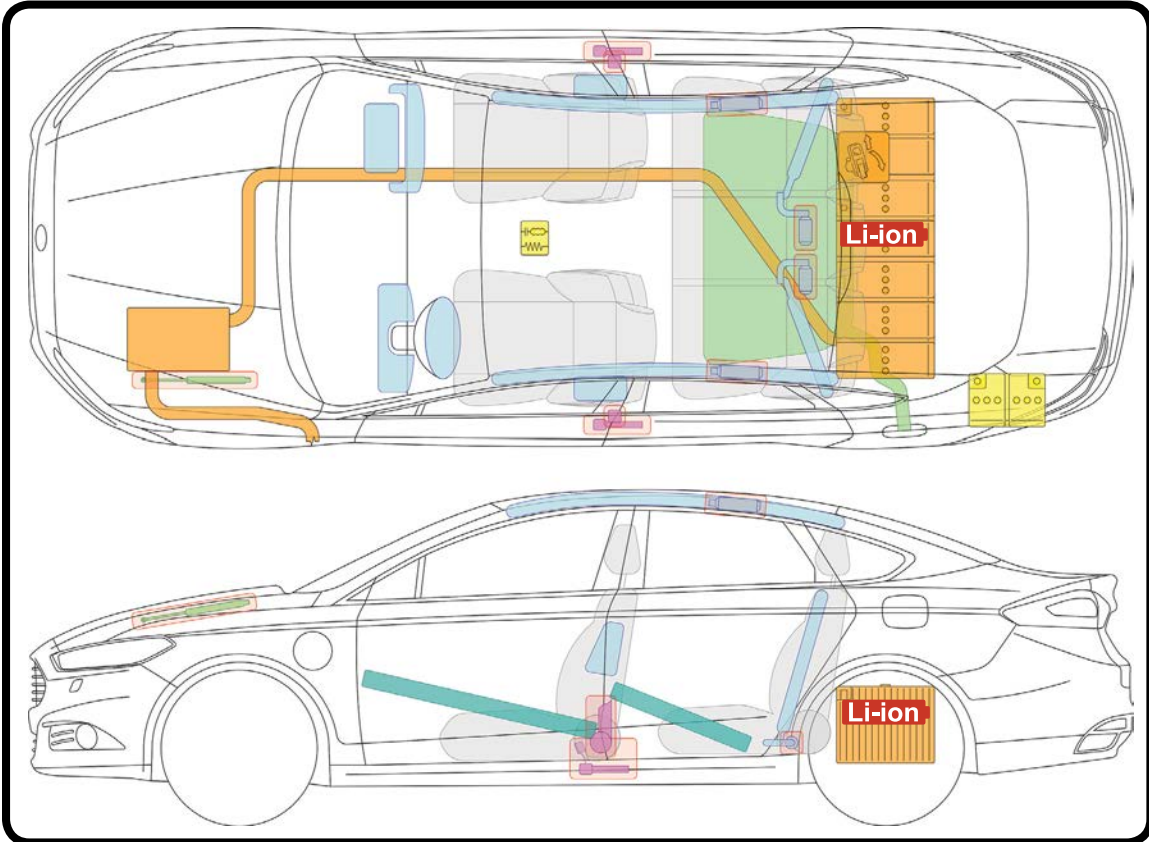

LEGEND		
Airbag	Bodywork Reinforcements	SRS Control Unit
Stored Gas Inflator	Support Cylinder for Hood	12V Battery
Seatbelt Tensioner or Pretensioner	Fuel Tank	High-Voltage Power Cable
High-Voltage Battery	Emergency Disconnect (Remove Plug)	

SUBMERSION

Ford recommends that a submerged vehicle not be removed from water until the high voltage battery is completely discharged (when microbubbling has completely stopped).

For towing and post-incident instructions, see the **POST-INCIDENT** section on page 20.



2003-18

GILLIG

VEHICLE INFORMATION

IMMOBILIZE VEHICLE

1. Chock the wheels.
2. Set parking brake.
3. Place vehicle into neutral.

DISABLE VEHICLE

PRIMARY PROCEDURE

1. Turn the ignition to the OFF position.
2. Turn off HV battery disconnect switch (driver's side, front of bus).

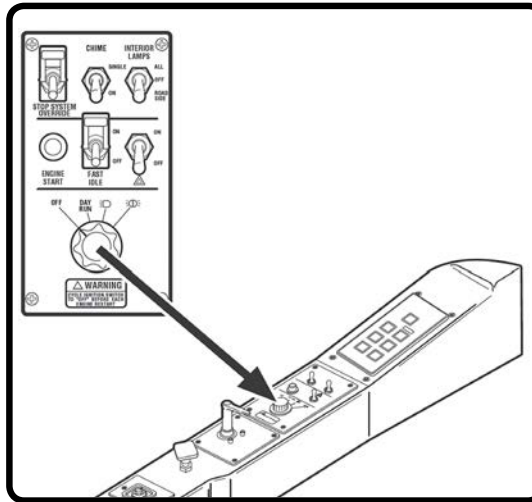

Turn Ignition Switch Off

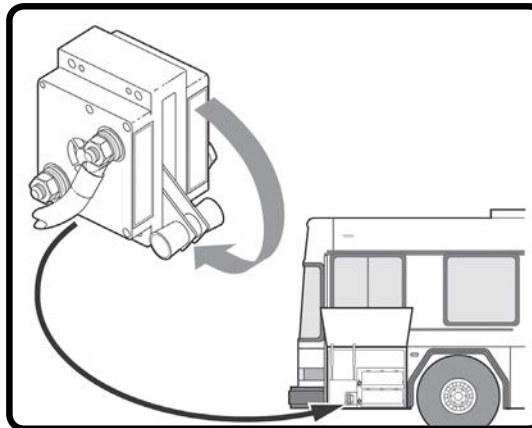

Battery Disconnect Switch

WARNINGS

- NEVER cut, breach, or touch high voltage components or cabling. Doing so could result in serious injury or death.
- When shutting down the high voltage system wait at least 4 minutes for complete discharge of the high voltage capacitor.
- Operating voltage of the hybrid drive system is 900 volts! NiMH batteries are used in the HV system.
- Lack of engine noise does not mean vehicle is OFF. Silent movement or instant restart capability exists until vehicle is fully shut down.

GILLIG

GILLIG

Allison Transmission



2003-18







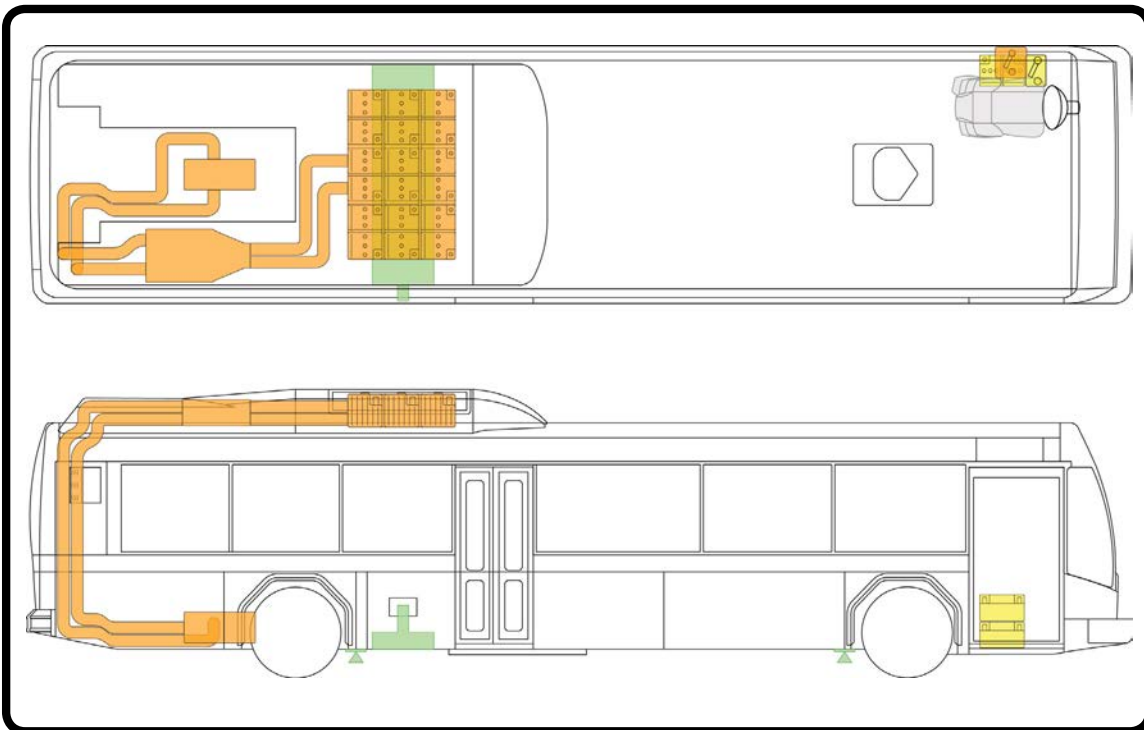

GILLIG

Allison Transmission

GILLIG

(continued) **EXTRICATION INFORMATION**



LEGEND			
	12V Battery		Fuel Tank
	High-Voltage Battery		Emergency Disconnect (Switch Off)
			High-Voltage Power Cable

For towing and post-incident instructions, see the **POST-INCIDENT** section on page 20.



2003-18

GILLIG

VEHICLE INFORMATION

IMMOBILIZE VEHICLE

1. Chock the wheels.
2. Set parking brake.
3. Place vehicle into neutral.

DISABLE VEHICLE

PRIMARY PROCEDURE

1. Turn the key to the OFF position.
2. Turn off HV battery disconnect switch (driver's side, front of bus).

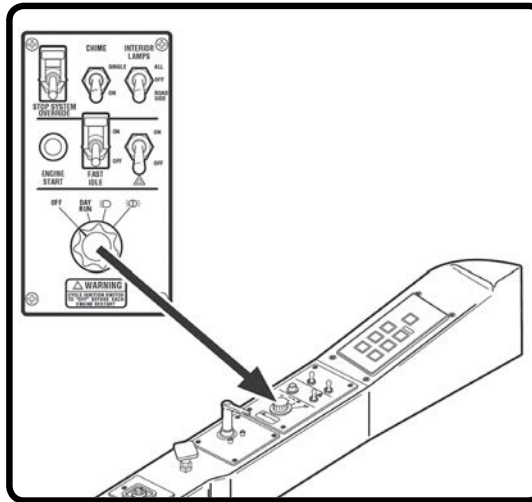

Turn Ignition Switch Off

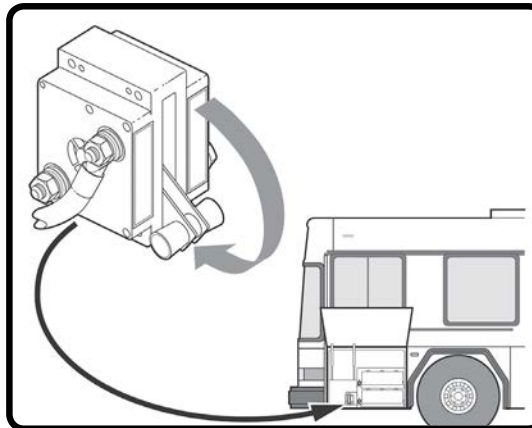

Battery Disconnect Switch

WARNINGS

- NEVER cut, breach, or touch high voltage components or cabling. Doing so could result in serious injury or death.
- When shutting down the high voltage system wait at least 4 minutes for complete discharge of the high voltage capacitor.
- Operating voltage of the hybrid drive system is 640 volts! Lithium-ion batteries are used in the HV system.
- Lack of engine noise does not mean vehicle is OFF. Silent movement or instant restart capability exists until vehicle is fully shut down.

GILLIG





GILLIG

BAE Transmission

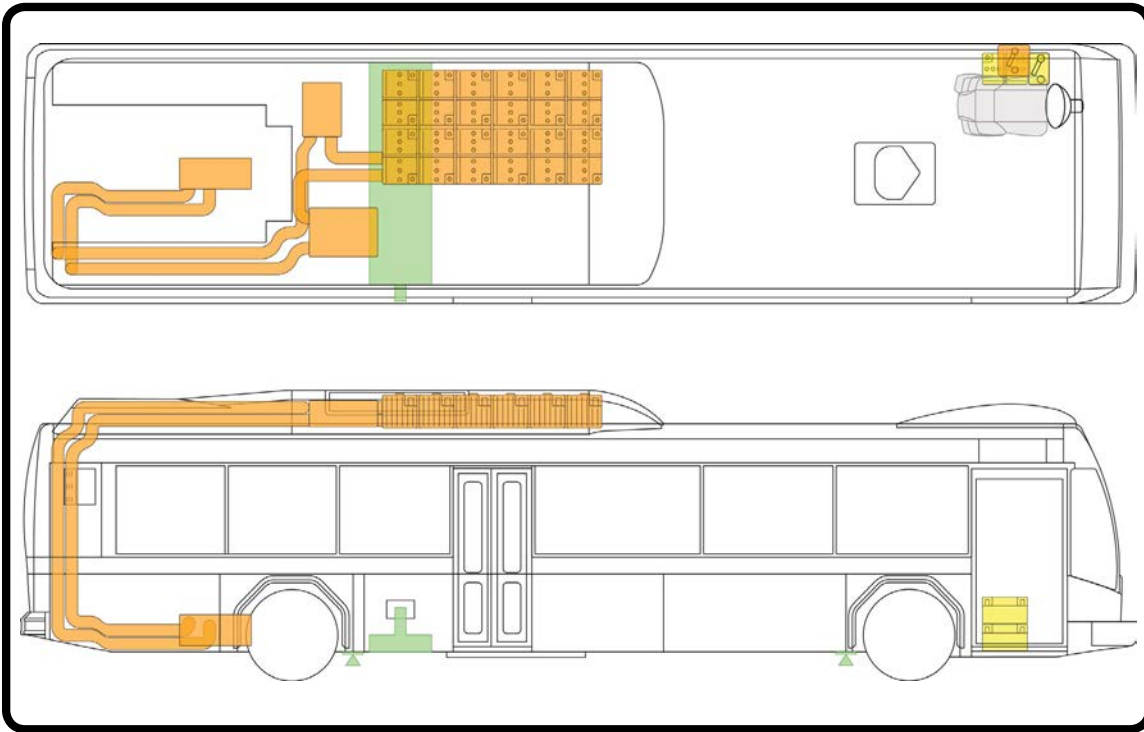

(continued) **EXTRICATION INFORMATION**



LEGEND			
	12V Battery		Fuel Tank
	High-Voltage Battery		Emergency Disconnect (Switch Off)
			High-Voltage Power Cable

For towing and post-incident instructions, see the **POST-INCIDENT** section on page 20.



2011-19



VEHICLE INFORMATION

 See page 25.

IMMOBILIZE VEHICLE

- 1. Chock the wheels.
- 2. Set parking brake. (foot pedal)
- 3. Place vehicle into park. (steering column)

DISABLE VEHICLE

PRIMARY PROCEDURE

- 1. Turn the ignition key to the OFF position.
- 2. Disconnect both 12V battery cables (engine compartment, passenger's side).
- 3. Turn the isolation valve, 1/4 turn to the OFF position (under the vehicle, midway between the front and rear tires on the inside of the driver's side frame).

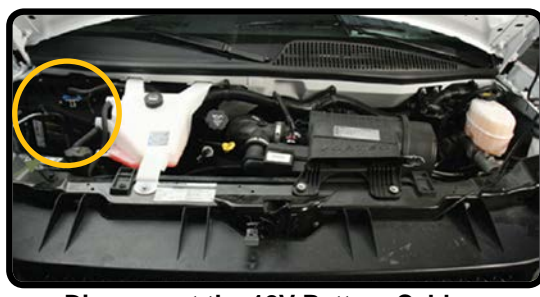

Disconnect the 12V Battery Cables

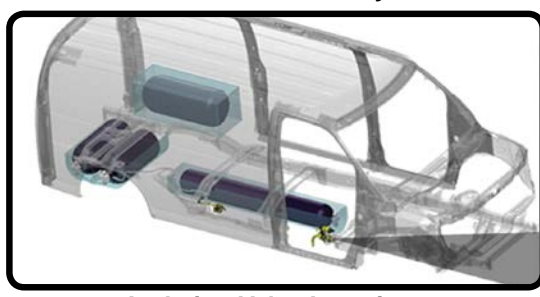



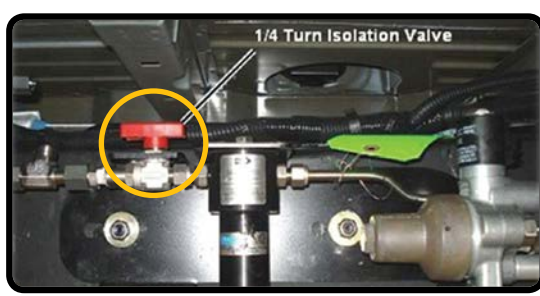

Isolation Valve Location



Turn Isolation Valve 1/4 Turn

WARNINGS

-  Do NOT cut the fuel lines, cutting fuel lines will release the natural gas in the fuel lines.
-  Do NOT try to stop a leak by over-tightening any fitting or isolation valve.
-  The SRS system (airbags, etc.) may remain powered for up to 1 minute after disabling.
-  Natural gas becomes flammable at concentrations between 5% and 15% in air.

GMC

GMC

SAVANA

CNG

GMC

2011-19

CNG







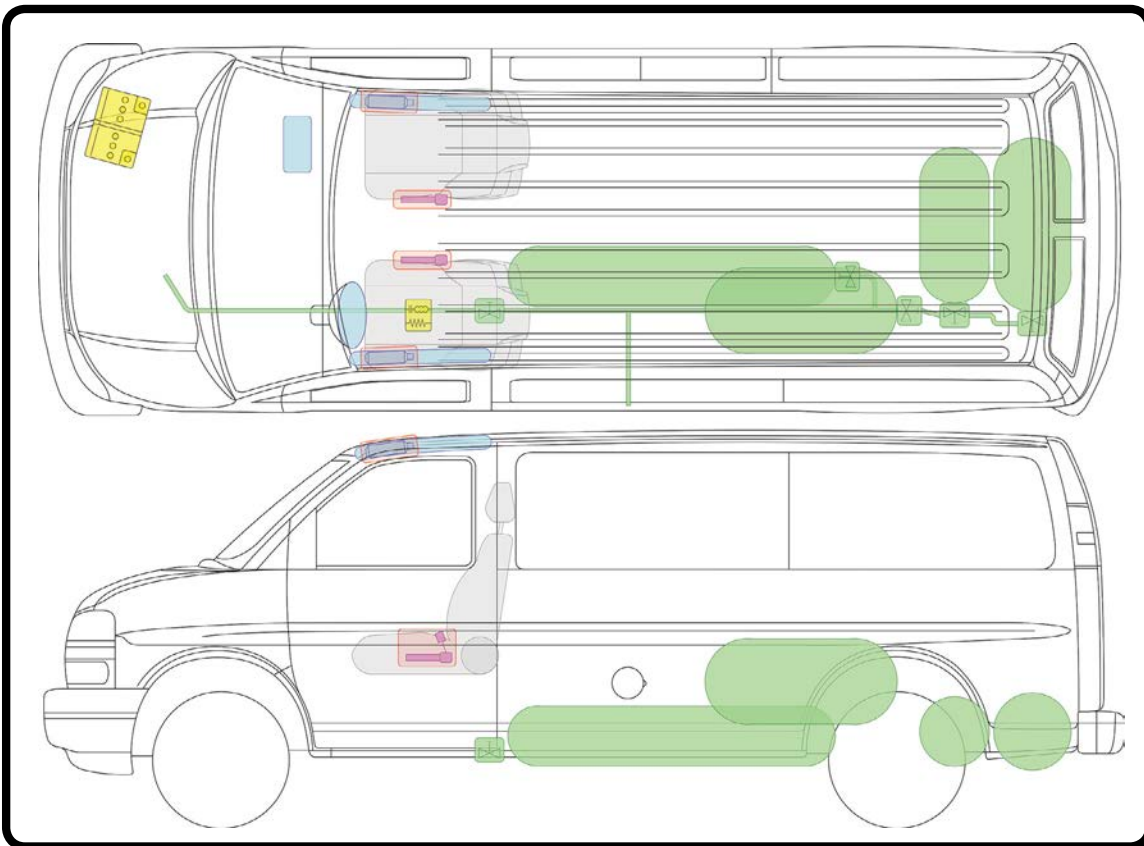

SAVANNA

See page 25.

(continued) **EXTRICATION INFORMATION**

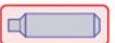

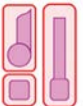
LEGEND

 Airbag		 SRS Control Unit
 Stored Gas Inflator		 12V Battery
 Seatbelt Tensioner or Pretensioner	 Fuel Tank	 Pressure Relief Valve

For towing and post-incident instructions, see the **POST-INCIDENT** section on page 20.

GMC



2011-19



GMC

GMC

SAVANNA

VEHICLE INFORMATION



IMMOBILIZE VEHICLE

- 1. **Chock the wheels.**
- 2. **Set parking brake.**
(foot pedal)
- 3. **Place vehicle into park.**
(steering column)

DISABLE VEHICLE

PRIMARY PROCEDURE

- 1. Turn the ignition key to the OFF position.
- 2. Disconnect both 12V battery cables (engine compartment, passenger's side).

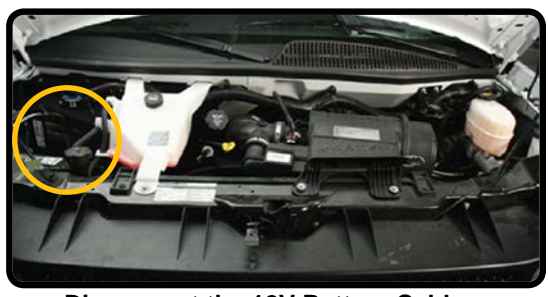

Disconnect the 12V Battery Cables

WARNINGS

- Do NOT cut the fuel lines, cutting fuel lines will release the propane in the fuel lines.
- Do NOT try to stop a leak by over-tightening any fitting or isolation valve.
- The SRS system (airbags, etc.) may remain powered for up to 1 minute after disabling.
- Propane gas becomes flammable at concentrations between 2.15% and 9.7% in air.

LPG

GMC

2011-19



SAVANNA







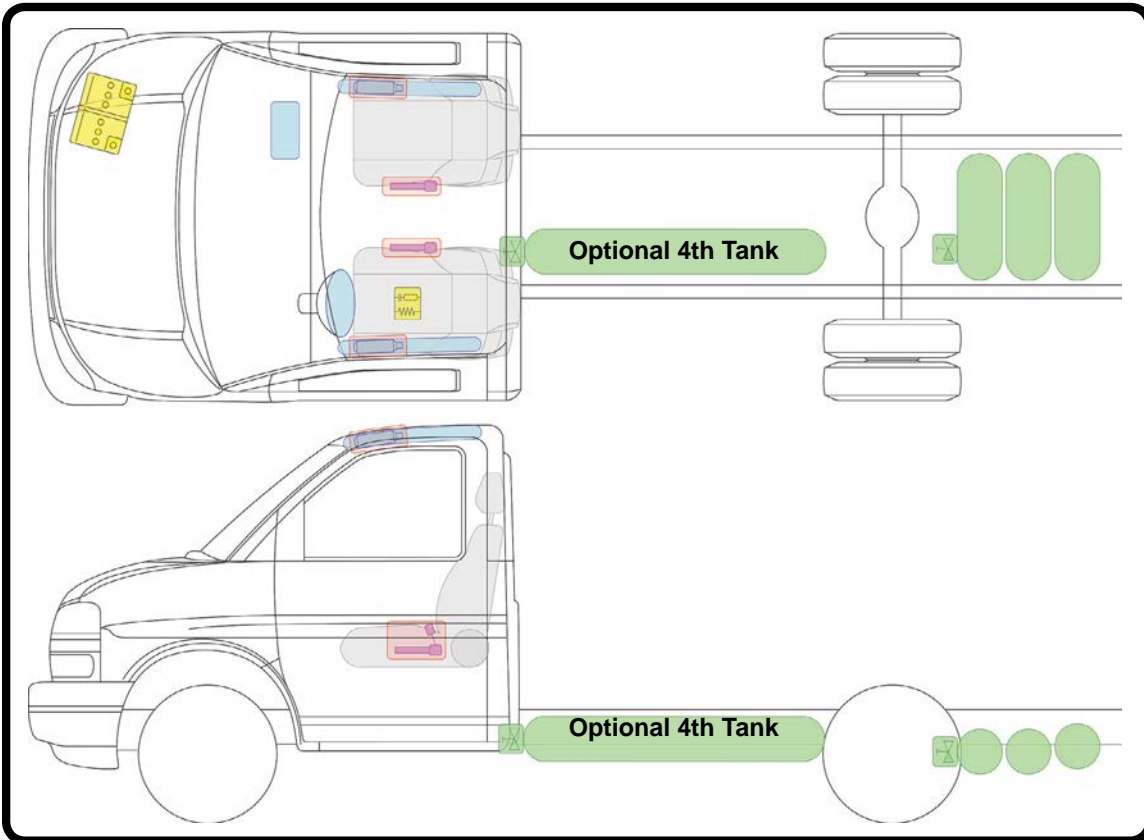

(continued)

EXTRICATION INFORMATION

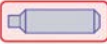

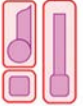
LEGEND

 Airbag		 SRS Control Unit
 Stored Gas Inflator		 12V Battery
 Seatbelt Tensioner or Pretensioner	 Fuel Tank	 Pressure Relief Valve

For towing and post-incident instructions, see the **POST-INCIDENT** section on page 20.

GMC

GMC



2004-07



HYBRID

VEHICLE INFORMATION

IMMOBILIZE VEHICLE

- 1. Chock the wheels.
- 2. Set parking brake. (foot pedal)
- 3. Place vehicle into park. (steering column)

DISABLE VEHICLE

PRIMARY PROCEDURE

- 1. Turn the vehicle's ignition off (steering column, key). Remove key.
- 2. Turn the Service Disconnect Switch to the OFF (horizontal position), located in the right side of the Energy Storage Box, under rear passengers seat.
- 3. Disconnect 12V negative (-) battery cable, then positive (+) battery cable.
- 4. Ensure the terminal cannot contact the battery post.







Service Disconnect Switch

ALTERNATE PROCEDURE

(if the ignition key is not accessible)

- 1. Turn the Service Disconnect Switch to the OFF (horizontal position), located in the right side of the Energy Storage Box, under rear passengers seat.
- 2. Disconnect 12V negative (-) battery cable, then positive (+) battery cable.
- 3. Ensure the terminal cannot contact the battery post.

WARNINGS

-  NEVER cut, breach, or touch orange high voltage components or cabling. Doing so could result in serious injury or death.
-  The high voltage system may remain powered for up to 1 minute after the vehicle is shut off.
-  The SRS system (airbags, etc.) may remain powered for up to 1 minute after disabling.
-  Lack of engine noise does not mean vehicle is OFF. Silent movement or instant restart capability exists until vehicle is fully shut down.

GMC

GMC

SIERRA

GMC

2004-07







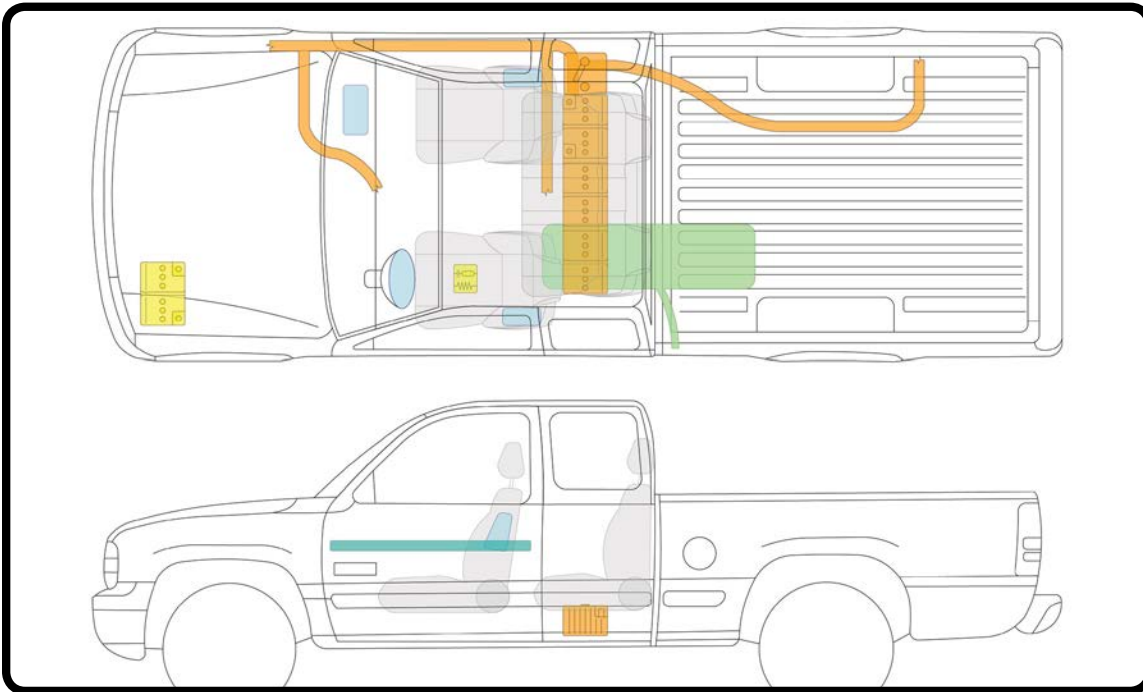

HYBRID

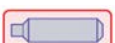

SIERRA

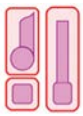
(continued) **EXTRICATION INFORMATION**



LEGEND		
 Airbag	 Bodywork Reinforcements	 SRS Control Unit
 Stored Gas Inflator		 12V Battery
 Seatbelt Tensioner or Pretensioner	 Fuel Tank	 High-Voltage Power Cable
 High-Voltage Battery	 Emergency Disconnect (Switch Off)	

NEUTRALIZING THE 120 VAC OUTLETS

1. If the 120 VAC APO indicator is ON, depress the APO button.
2. Turn off Engine (Remove key).



120 VAC Outlets

For towing and post-incident instructions, see the **POST-INCIDENT** section on page 20.

GMC



2009-13



VEHICLE INFORMATION

IMMOBILIZE VEHICLE

1. Chock the wheels.
2. Set parking brake.
3. Place vehicle into park. (steering column)

DISABLE VEHICLE

Determine if vehicle is ON.

- Vehicle is ON if tachometer needle points to AUTO STOP.
- Vehicle is OFF if needle points to OFF.

PRIMARY PROCEDURE

1. If ON, turn the vehicle's ignition off (steering column, key). Remove key.
2. Disconnect 12V positive (+) battery cable (engine compartment, driver's side). 12V battery has lever-type quick release terminals.
3. Ensure the terminal cannot contact the battery post.

ALTERNATE PROCEDURE

(if the ignition key is not accessible)

1. Disconnect the 12V positive (+) battery cable (engine compartment, driver's side).
2. Cut all three exposed 12V positive cables identified by the yellow First Responder labels.



Cut 3 Exposed Cables (Alternate Procedure)

HIGH VOLTAGE MANUAL DISCONNECT

If accessible, you can minimize potential for high voltage current flow by removing the manual disconnect lever from the high voltage battery. It is located under the second row seat, accessed from the passenger's side.



300V Hybrid Battery Manual Disconnect

WARNINGS

- NEVER cut, breach, or touch orange high voltage components or cabling. Doing so could result in serious injury or death.
- The high voltage system may remain powered for up to 1 minute after the vehicle is shut off.
- The SRS system (airbags, etc.) may remain powered for up to 1 minute after disabling.
- Lack of engine noise does not mean vehicle is OFF. Silent movement or instant restart capability exists until vehicle is fully shut down.

GMC

GMC

SIERRA

HEV

GMC

2009-13









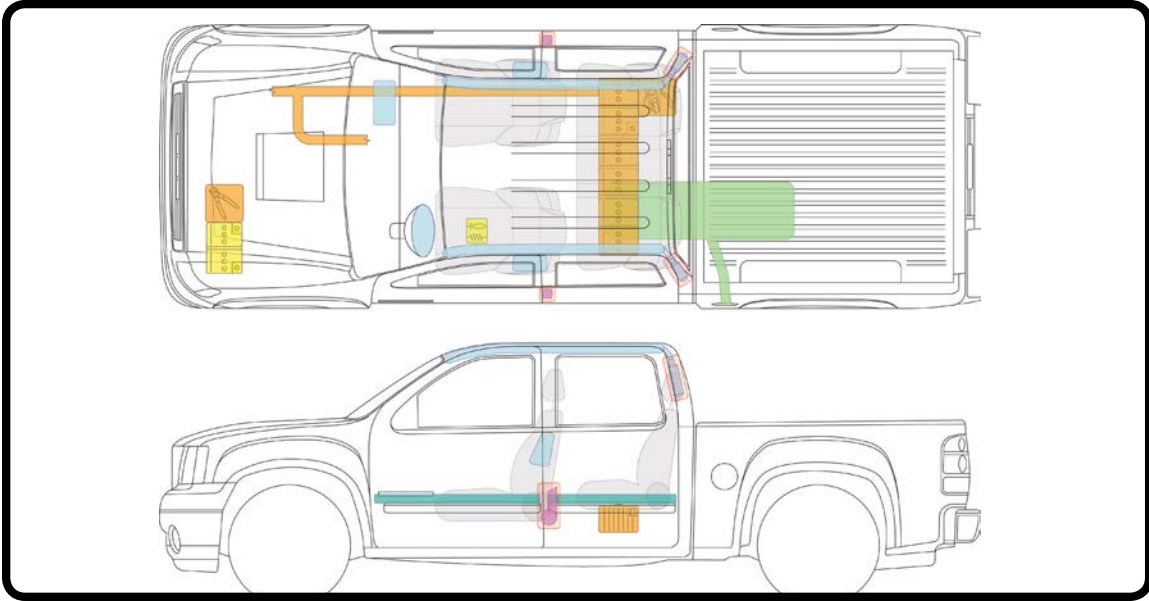

HYBRID



SIERRA

(continued) **EXTRICATION INFORMATION**

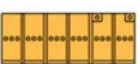

LEGEND		
 Airbag	 Bodywork Reinforcements	 SRS Control Unit
 Stored Gas Inflator		 12V Battery
 Seatbelt Tensioner or Pretensioner	 Fuel Tank	 High-Voltage Power Cable
 High-Voltage Battery	 Emergency Disconnect (Remove Plug)	 Emergency Disconnect (Cut Cable)

REMOVING THE SERVICE DISCONNECT (DETAIL)

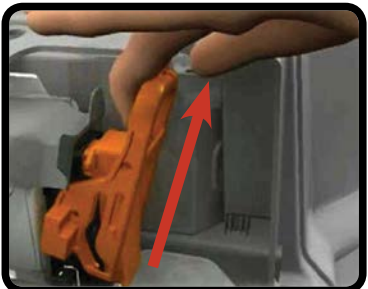

1. Pull Up

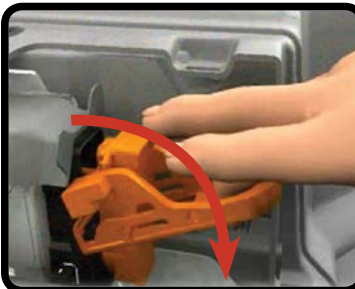

2. Pull Down

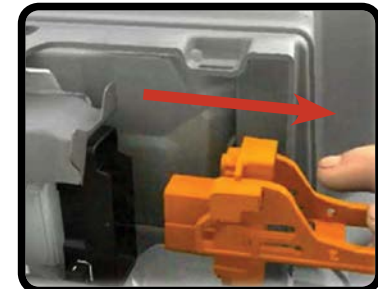

3. Pull Out

For towing and post-incident instructions, see the **POST-INCIDENT** section on page 20.

GMC

GMC



2015



VEHICLE INFORMATION



See page 25.

IMMOBILIZE VEHICLE

- 1. Chock the wheels.
- 2. Set parking brake. (foot pedal)
- 3. Place vehicle into park. (steering column)

DISABLE VEHICLE

PRIMARY PROCEDURE

- 1. Turn the ignition key to the OFF position.
- 2. Disconnect negative 12V battery cable (engine compartment, passenger's side).
- 3. Turn the isolation valve, counter clockwise to the OFF position (diamond plate access panel in bed of truck, driver side).

NOTE: This is a bi-fuel vehicle and can run on both compressed natural gas (CNG) and regular gasoline.

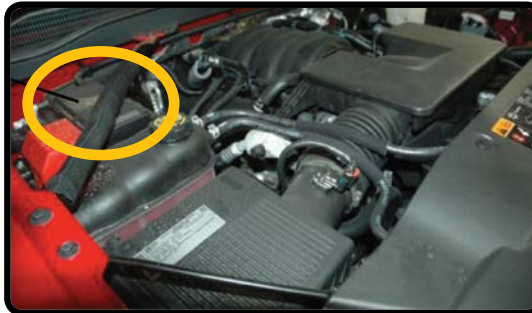

Disconnect 12V Negative Battery Cable

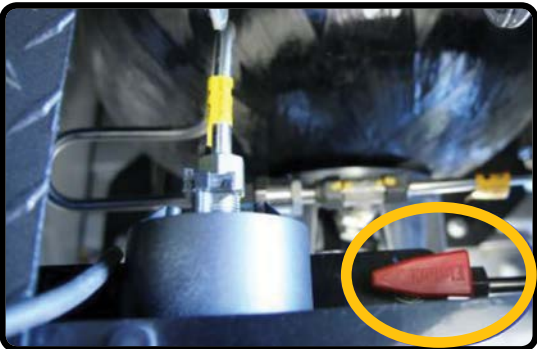

Turn Isolation Valve Counter Clockwise



Manual CNG Shut-Off

WARNINGS

- Do NOT cut the fuel lines, cutting fuel lines will release the natural gas in the fuel lines.
- Do NOT try to stop a leak by over-tightening any fitting or isolation valve.
- The SRS system (airbags, etc.) may remain powered for up to 1 minute after disabling.
- Natural gas becomes flammable at concentrations between 5% and 15% in air.

GMC

GMC

SIERRA



2015

CNG



SIERRRA

See page 25.

(continued) **EXTRICATION INFORMATION**

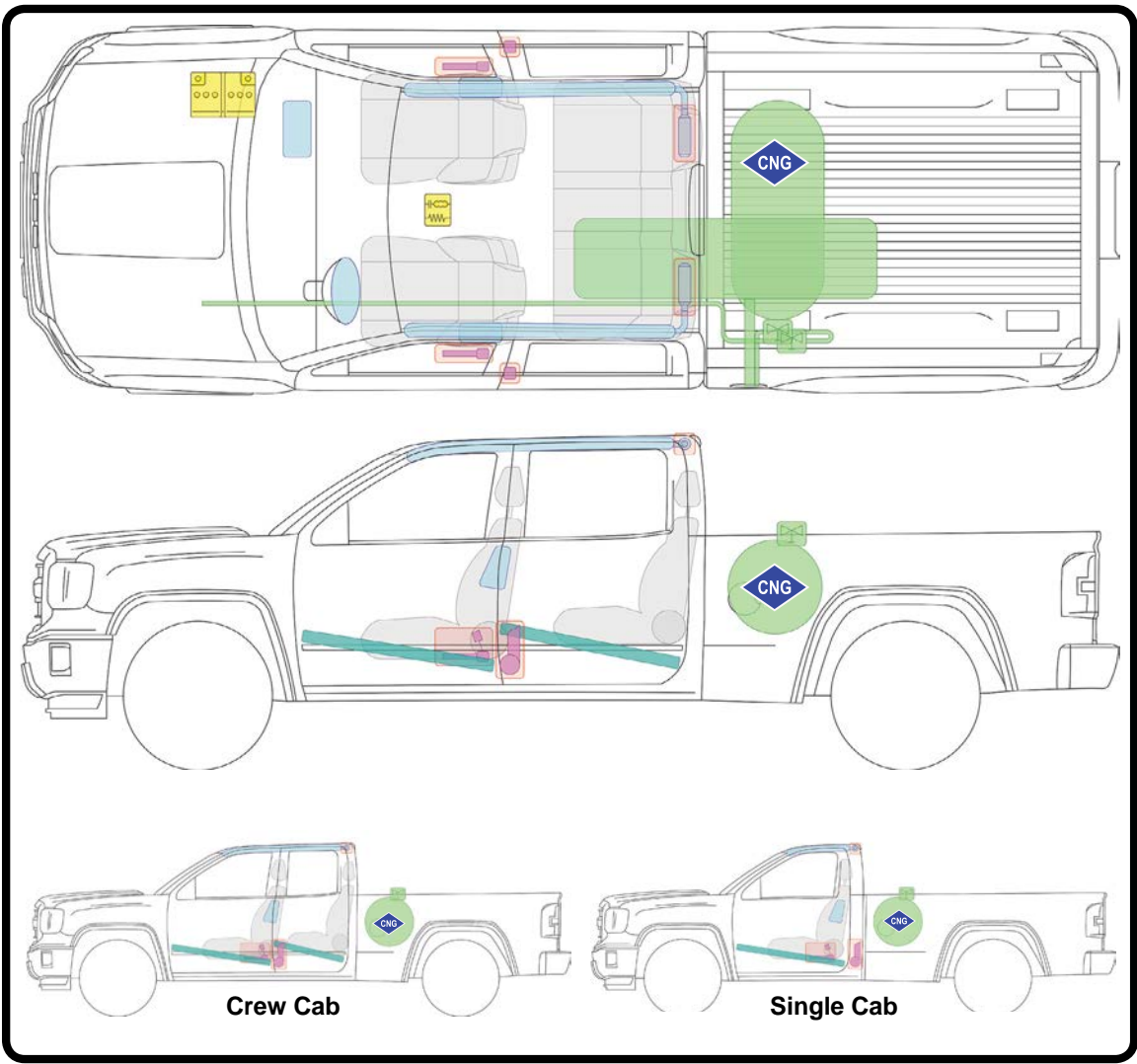

LEGEND			
	Airbag		Bodywork Reinforcements
	Stored Gas Inflator		SRS Control Unit
	Seatbelt Tensioner or Pretensioner		12V Battery
		Fuel Tank	
			Pressure Relief Valve

For towing and post-incident instructions, see the **POST-INCIDENT** section on page 20.

GMC

GMC



2016-18



VEHICLE INFORMATION

Li-ion

See pages 15, 22.

IMMOBILIZE VEHICLE

- 1. **Chock the wheels.**
- 2. **Set parking brake.**
(foot pedal)
- 3. **Place vehicle into park.**
(steering column)

DISABLE VEHICLE

Determine if vehicle is ON by illumination of the instrument displays.





PRIMARY PROCEDURE

- 1. Turn the ignition key to the OFF position.
- 2. Remove key.
- 3. Double cut all the low voltage cables marked by yellow tape above the 12V battery (passenger's side, engine compartment).



Cut All Marked Low Voltage Cables

WARNINGS

-  NEVER cut, breach, or touch orange high voltage components or cabling. Doing so could result in serious injury or death.
-  The high voltage system may remain powered for up to 1 minute after the vehicle is shut off.
-  The SRS system (airbags, etc.) may remain powered for up to 10 seconds after disabling.
-  Lack of engine noise does not mean vehicle is OFF. Silent movement or instant restart capability exists until vehicle is fully shut down.

GMC

SILVERADO

with eAssist

GMC

HEV

GMC

2016-18



with eAssist







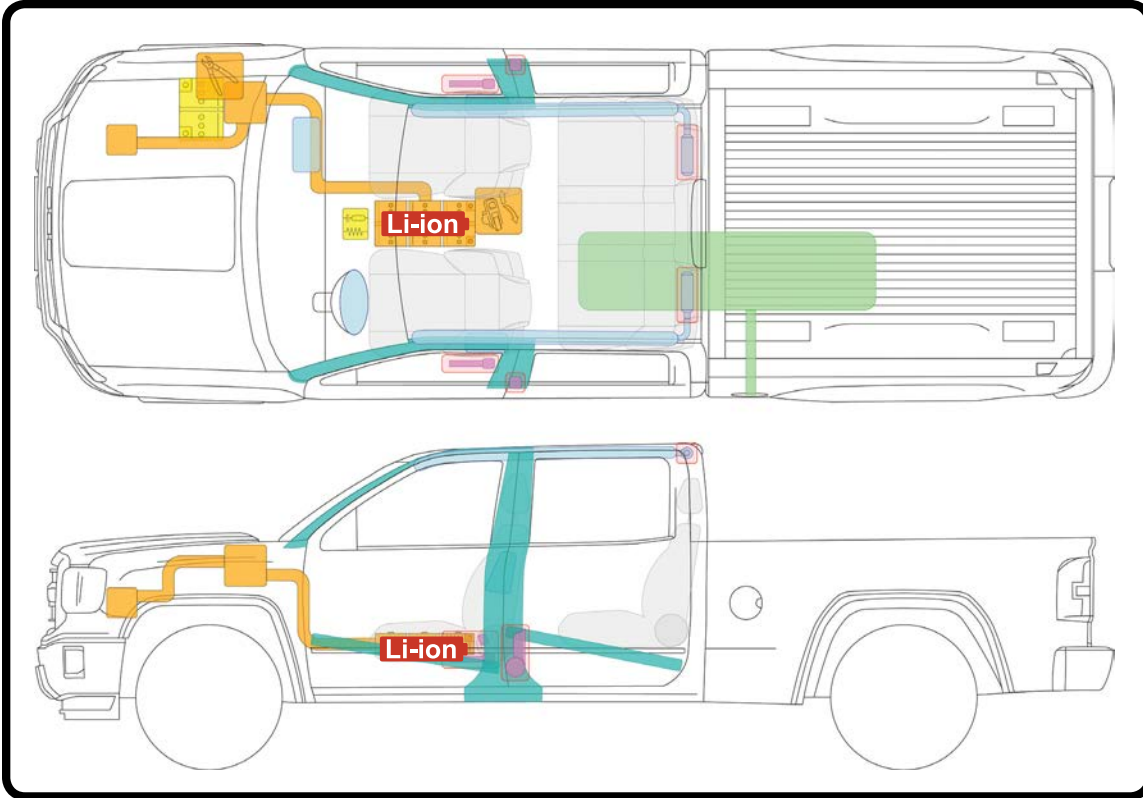



SIERRA

Li-ion (continued) **EXTRICATION INFORMATION**

See pages 15, 22.



LEGEND

 Airbag	 Bodywork Reinforcements	 SRS Control Unit
 Stored Gas Inflator		 12V Battery
 Seatbelt Tensioner or Pretensioner	 Fuel Tank	 High-Voltage Power Cable
 High-Voltage Battery	 Emergency Disconnect (Remove Plug)	 Emergency Disconnect (Cut Cable)

For towing and post-incident instructions, see the **POST-INCIDENT** section on page 20.

GMC



2009-14

GMC

HYBRID

VEHICLE INFORMATION

IMMOBILIZE VEHICLE

1. Chock the wheels.
2. Set parking brake.
3. Place vehicle into park. (steering column)

DISABLE VEHICLE

Determine if vehicle is ON.

- Vehicle is ON if tachometer needle points to AUTO STOP.
- Vehicle is OFF if needle points to OFF.

PRIMARY PROCEDURE

1. If ON, turn the vehicle's ignition off (steering column, key). Remove key.
2. Disconnect 12V positive (+) battery cable (engine compartment, driver's side). 12V battery has lever-type quick release terminals.
3. Ensure the terminal cannot contact the battery post.

ALTERNATE PROCEDURE

(if the ignition key is not accessible)

1. Disconnect the 12V positive (+) battery cable (engine compartment, driver's side).
2. Cut all three exposed 12V positive cables identified by the yellow First Responder labels.



Cut 3 Exposed Cables (Alternate Procedure)





HIGH VOLTAGE MANUAL DISCONNECT

If accessible, you can minimize potential for high voltage current flow by removing the manual disconnect lever from the high voltage battery. It is located under the passenger's side, second row, rear sub-floor.



300V Hybrid Battery Manual Disconnect

WARNINGS

-  NEVER cut, breach, or touch orange high voltage components or cabling. Doing so could result in serious injury or death.
-  The high voltage system may remain powered for up to 1 minute after the vehicle is shut off.
-  The SRS system (airbags, etc.) may remain powered for up to 1 minute after disabling.
-  Lack of engine noise does not mean vehicle is OFF. Silent movement or instant restart capability exists until vehicle is fully shut down.

GMC

GMC

YUKON

HEV

GMC

2009-14

HYBRID







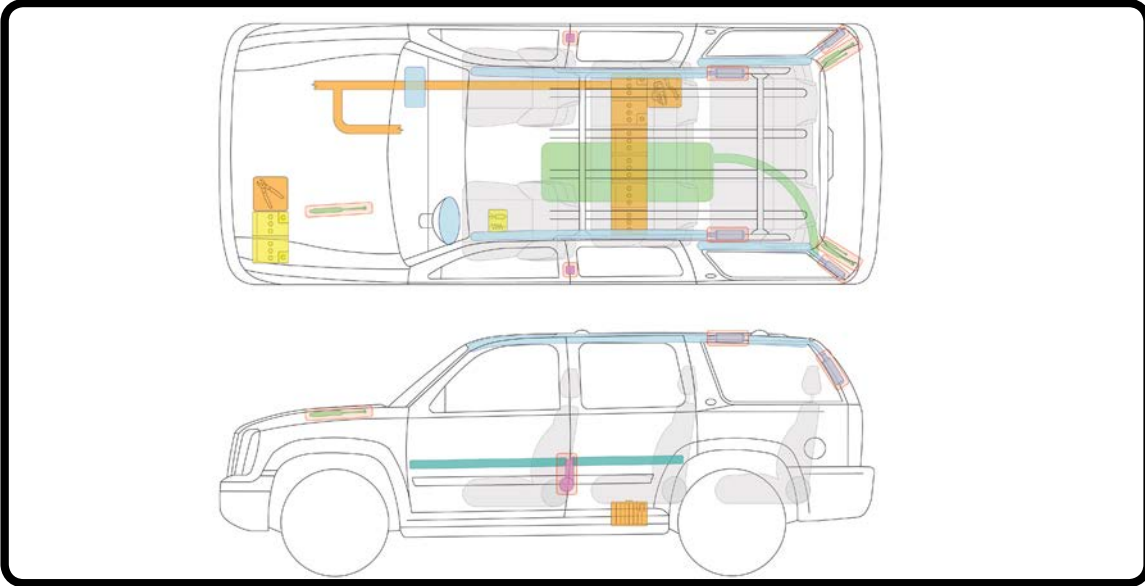





YUKON

(continued) **EXTRICATION INFORMATION**

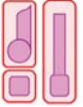

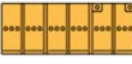
LEGEND

 Airbag	 Bodywork Reinforcements	 SRS Control Unit
 Stored Gas Inflator	 Support Cylinder for Hood	 12V Battery
 Seatbelt Tensioner or Pretensioner	 Fuel Tank	 High-Voltage Power Cable
 High-Voltage Battery	 Emergency Disconnect (Remove Plug)	 Emergency Disconnect (Cut Cable)

REMOVING THE SERVICE DISCONNECT (DETAIL)



1. Pull Up

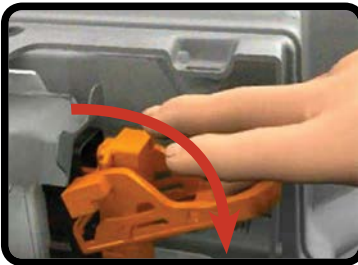

2. Pull Down

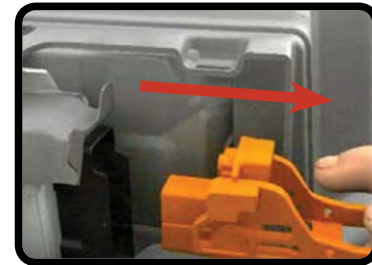

3. Pull Out

For towing and post-incident instructions, see the **POST-INCIDENT** section on page 20.

GMC

GMC



2011-18

195h Hybrid

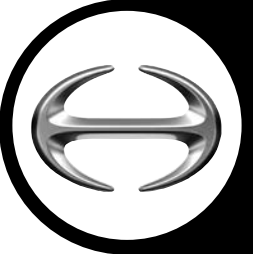

VEHICLE INFORMATION

IMMOBILIZE VEHICLE

- 1. Chock the wheels.
- 2. Set parking brake. (hand brake, center console)
- 3. Place vehicle into park. (center console)

DISABLE VEHICLE

PRIMARY PROCEDURE

- 1. If ON, turn the vehicle's ignition off (key, steering column). Remove key.
- 2. Remove 12V battery cover by releasing spring clips (driver's side, attached to the vehicle frame).
- 3. Cut out a section of the negative cable by making two cuts, then cut the positive cable.



Cut Section Out of the Negative Cable

ALTERNATE PROCEDURE

(if ignition is inaccessible)

- 1. Remove 12V battery cover by releasing spring clips (driver's side, attached to the vehicle frame).
- 2. Cut out a section of the negative cable by making two cuts, then cut the positive cable.
- 3. Remove the 4 bolts (10mm) of the service plug cover (side of the battery pack, driver's side, vehicle frame).
- 4. Pull the handle towards the front of the vehicle, then rotate handle towards outside of vehicle, and pull service plug out.



Cut the Positive Battery Cable



Remove 4 (10mm) Bolts



Pull Service Plug Forward



Rotate Handle Then Pull Out

WARNINGS

- NEVER cut, breach, or touch orange high voltage components or cabling. Doing so could result in serious injury or death.
- The high voltage system may remain powered for up to 7 minutes after the vehicle is shut off or the service disconnect plug has been removed.
- If removing high voltage service plug use "Class 0" insulated gloves.
- Lack of engine noise does not mean vehicle is OFF. Silent movement or instant restart capability exists until vehicle is fully shut down.

HINO

HINO

195h

HEV

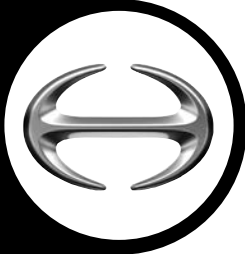

2011-18

195h Hybrid



195h

(continued) EXTRICATION INFORMATION

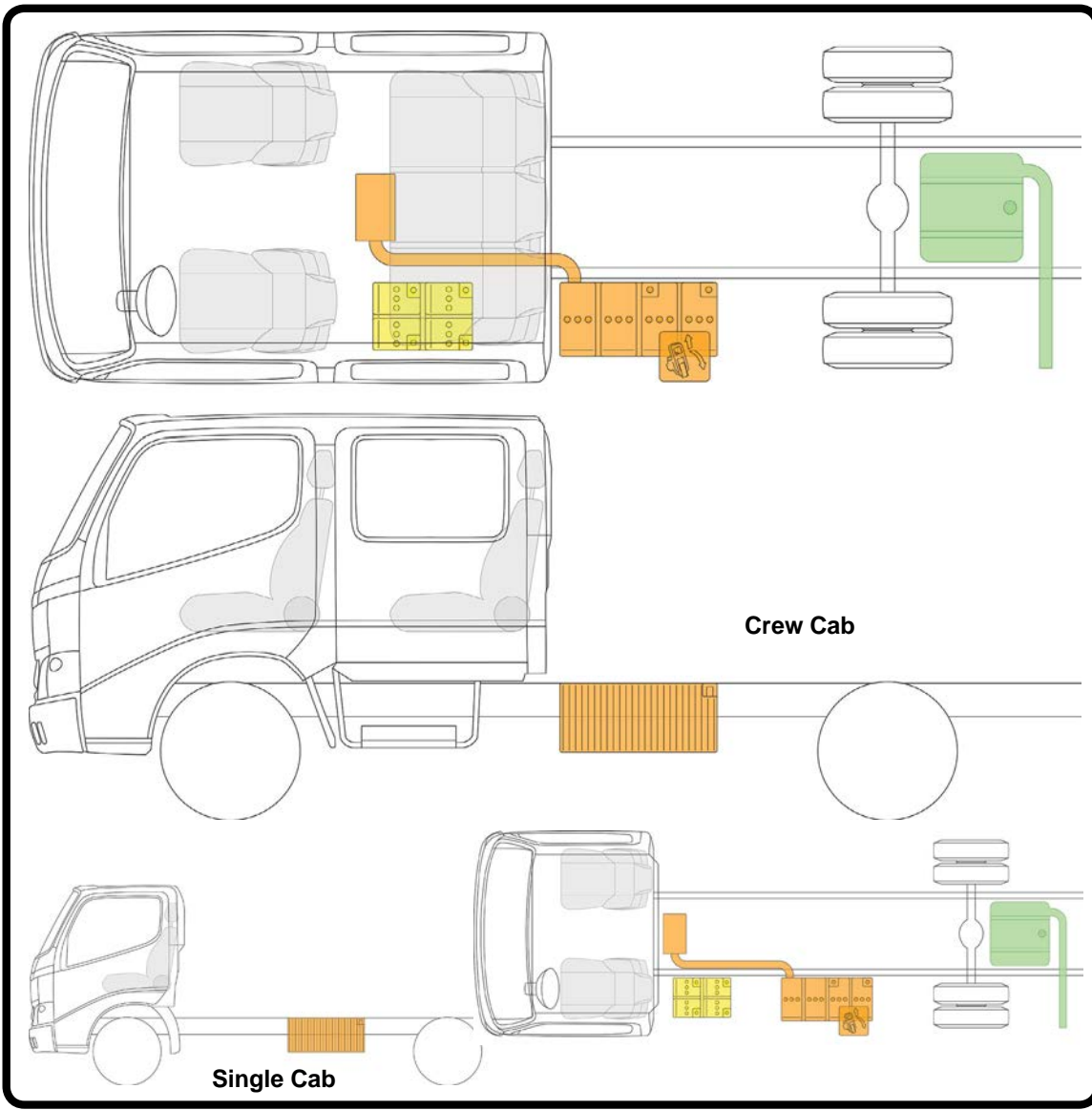

LEGEND			
	High-Voltage Battery		Fuel Tank
	Emergency Disconnect (Remove Plug)		12V Battery
	High-Voltage Power Cable		

For towing and post-incident instructions, see the **POST-INCIDENT** section on page 20.

HINO



2005-07



VEHICLE INFORMATION

IMMOBILIZE VEHICLE

1. **Chock the wheels.**
2. **Set parking brake.**
(hand brake, center console)
3. **Place vehicle into park.**
(center console)

DISABLE VEHICLE

PRIMARY PROCEDURE

1. If ON, turn the vehicle's ignition off (key, steering column). Remove key.
2. Cut both negative cables on the 12V battery (engine compartment, driver's side front).

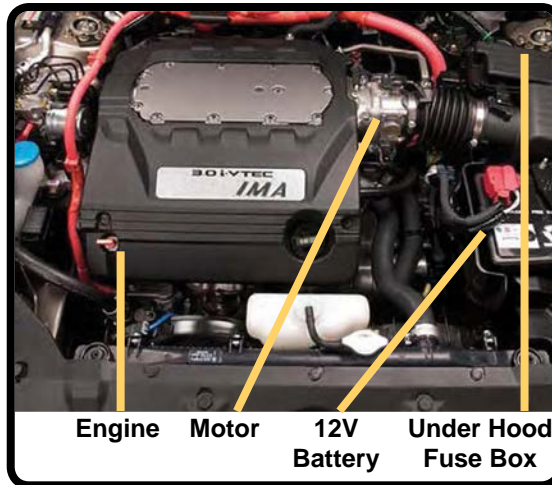

12V Battery Location

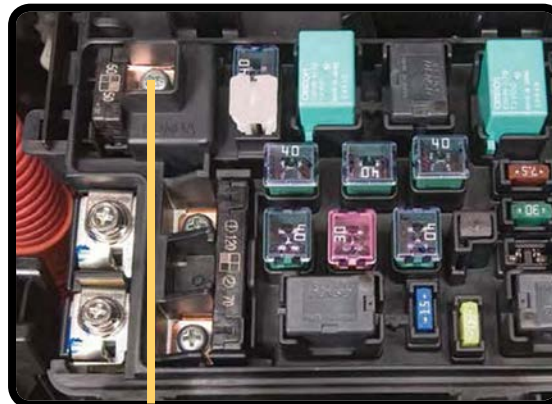

ALTERNATE PROCEDURE

1. Cut both negative cables on the 12V battery (engine compartment, driver's side front).
2. Remove main fuse (underhood fuse box, driver's side).



Main Fuse Screw Locations

WARNINGS

-  NEVER cut, breach, or touch orange high voltage components or cabling. Doing so could result in serious injury or death.
-  Airbag capacitors have a 3 minute deactivation time after disconnecting 12V power. During this time, the airbag system remains active and the potential for unintentional deployment exists. Do not cut into the center of steering wheel or dashboard airbag storage, and if cutting into the C pillar, identify the location of the airbag inflators prior to making any cuts.
-  Lack of engine noise does not mean vehicle is OFF. Silent movement or instant restart capability exists until vehicle is fully shut down.

HONDA

ACCORD

HONDA

HEV









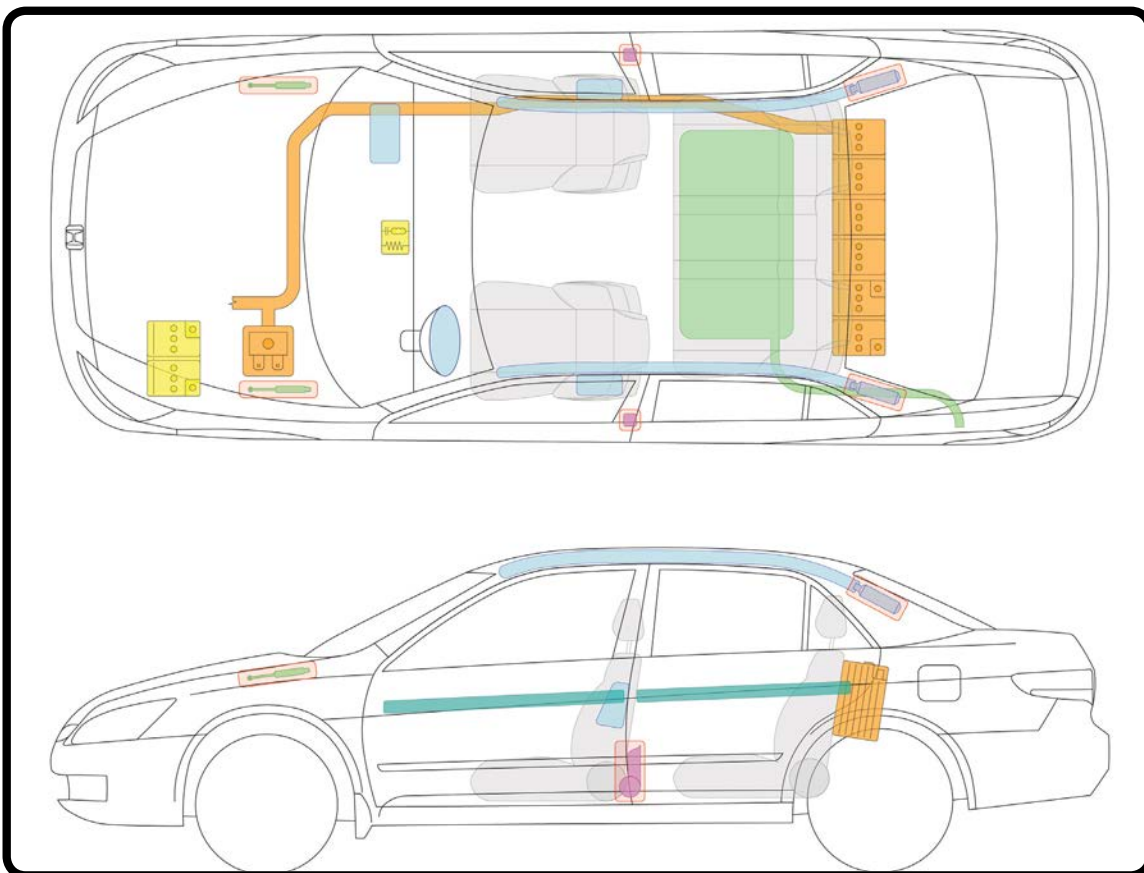



2005-07

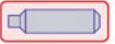

(continued) **EXTRICATION INFORMATION**

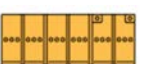

LEGEND

 Airbag	 Bodywork Reinforcements	 SRS Control Unit
 Stored Gas Inflator	 Support Cylinder for Hood	 12V Battery
 Seatbelt Tensioner or Pretensioner	 Fuel Tank	 High-Voltage Power Cable
 High-Voltage Battery	 Emergency Disconnect (Remove Fuse)	

For towing and post-incident instructions, see the **POST-INCIDENT** section on page 20.

HONDA ACCORD



2014-15

2017

2014-15,17



VEHICLE INFORMATION

Li-ion

See pages 15, 22.

IMMOBILIZE VEHICLE

1. **Chock the wheels.**
2. **Set parking brake.**
(hand brake, center console)
3. **Place vehicle into park.**
(center console)

DISABLE VEHICLE

PRIMARY PROCEDURE

1. If ON, turn vehicle off by pressing START/STOP button for 3 seconds (right of steering column). Remove the proximity key at least 20 feet from vehicle.
2. Locate the 12V battery (driver side, engine compartment) and Cut the negative battery cable.

ALTERNATE PROCEDURE

1. Locate the 12V battery (driver side, engine compartment) and Cut the negative battery cable first (1), then cut the DC to DC Converter cable (2).

NOTE: If cutting the DC to DC Converter Cable, do not allow the cutting tool to contact any surrounding metal parts; electrical arcing could occur.

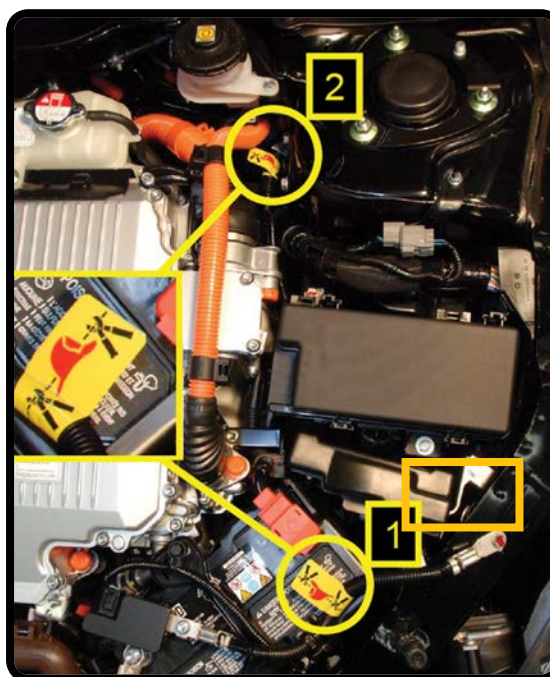

**Cut Negative Battery Cable First
Then Cut TheDC to DC Converter Cable**

WARNINGS

- NEVER cut, breach, or touch orange high voltage components or cabling. Doing so could result in serious injury or death.
- Airbag capacitors have a 3 minute deactivation time after disconnecting 12V power. During this time, the airbag system remains active and the potential for unintentional deployment exists. Do not cut into the center of steering wheel or dashboard airbag storage, and if cutting into the C pillar, identify the location of the airbag inflators prior to making any cuts.
- In the event of a fire involving a charging station, reference the **FIRE** portion of this guide, and treat it as an energized electrical fire until power to the charger can be shut down.
- Lack of engine noise does not mean vehicle is OFF. Silent movement or instant restart capability exists until vehicle is fully shut down.
- Vehicle contains a lithium-ion battery that if damaged can increase the a possibility of fire. See more information about lithium-ion batteries on pages 15, 22.

HONDA ACCORD

HONDA

HEV



2014-15,17



2017



2014-15

Li-ion







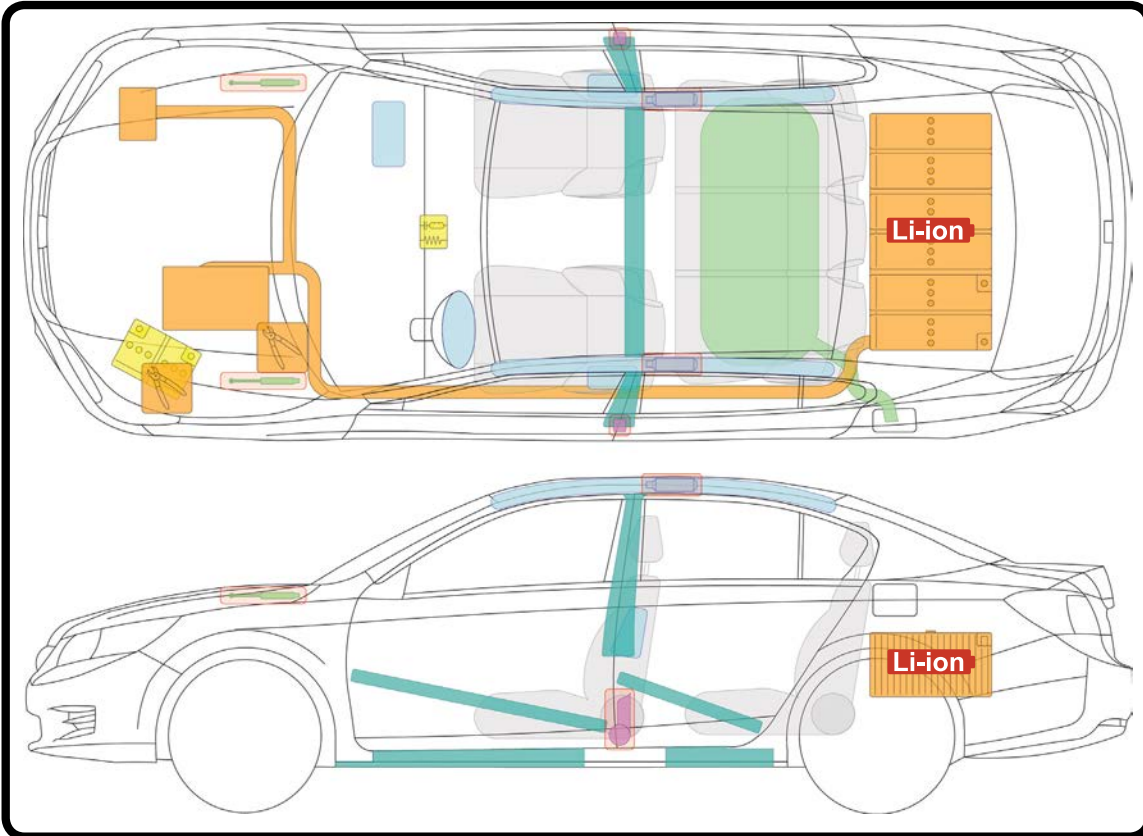

See pages 15, 22.

(continued)

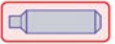
EXTRICATION INFORMATION

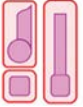

LEGEND

 Airbag	 Bodywork Reinforcements	 SRS Control Unit
 Stored Gas Inflator	 Support Cylinder for Hood	 12V Battery
 Seatbelt Tensioner or Pretensioner	 Fuel Tank	 High-Voltage Power Cable
 High-Voltage Battery	 Emergency Disconnect (Cut Cable)	

For towing and post-incident instructions, see the **POST-INCIDENT** section on page 20.



2018



VEHICLE INFORMATION

Li-ion

See pages 15, 22.

IMMOBILIZE VEHICLE

1. **Chock the wheels.**
2. **Set parking brake.**
(push button, center console)
3. **Place vehicle into park.**
(push button, center console)

DISABLE VEHICLE

PRIMARY PROCEDURE

1. If ON, turn vehicle off by pressing START/STOP button for 3 seconds (right of steering column). Remove the proximity key at least 20 feet from vehicle.
2. Locate the 12V battery (driver side, engine compartment) and Cut the negative battery cable.



Power Button

ALTERNATE PROCEDURE

1. Locate the 12V battery (driver side, engine compartment) and Cut the negative battery cable first (1), then cut the DC to DC Converter cable (2).

NOTE: If cutting the DC to DC Converter Cable, do not allow the cutting tool to contact any surrounding metal parts; electrical arcing could occur.

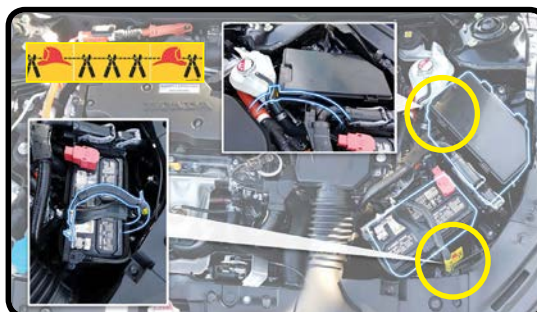

12V Negative and DC to DC Cable



If You Need to Cut The Hood To Open It, Be Sure To Stay Within The Cut Zone

WARNINGS

- NEVER cut, breach, or touch orange high voltage components or cabling. Doing so could result in serious injury or death.
- Airbag capacitors have a 3 minute deactivation time after disconnecting 12V power. During this time, the airbag system remains active and the potential for unintentional deployment exists. Do not cut into the center of steering wheel or dashboard airbag storage, and if cutting into the C pillar, identify the location of the airbag inflators prior to making any cuts.
- Lack of engine noise does not mean vehicle is OFF. Silent movement or instant restart capability exists until vehicle is fully shut down.
- Vehicle contains a lithium-ion battery that if damaged can increase the a possibility of fire. See more information about lithium-ion batteries on pages 15, 22.

HONDA ACCORD

HONDA



2018







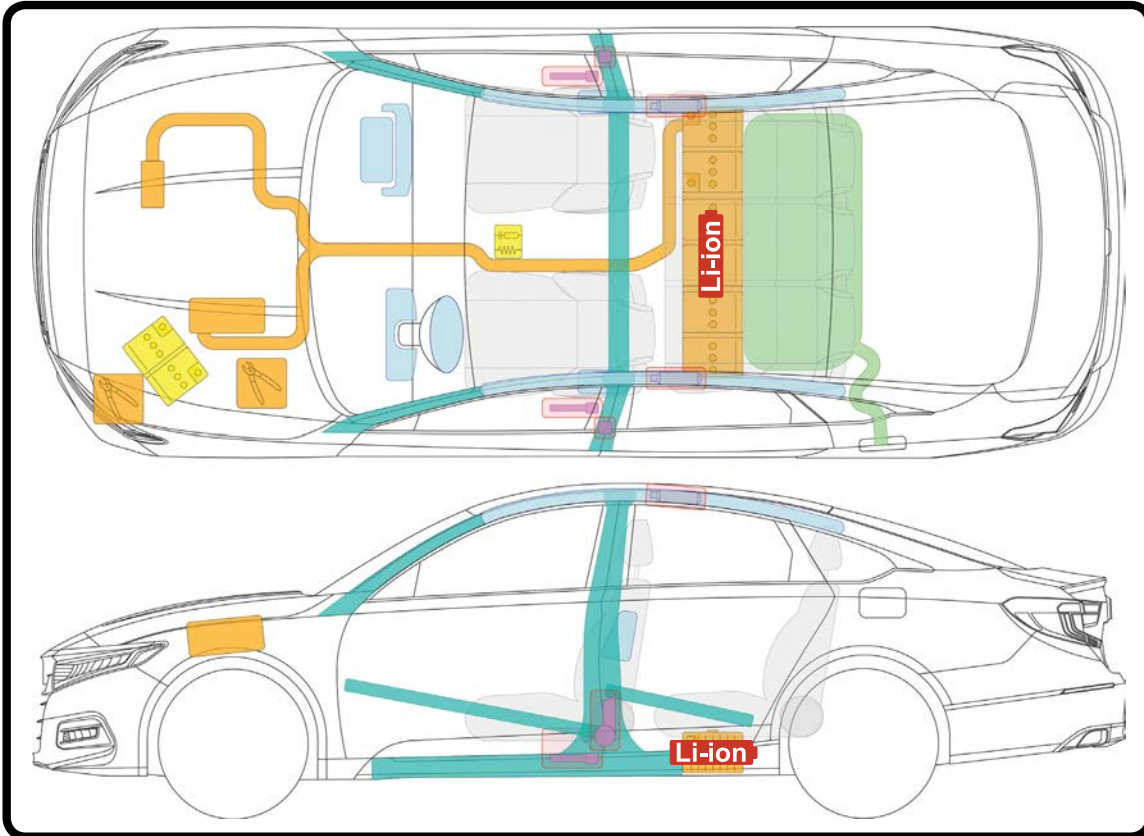

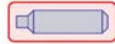

Li-ion (continued) **EXTRICATION INFORMATION**

See pages 15, 22.

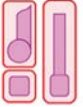

LEGEND

 Airbag	 Bodywork Reinforcements	 SRS Control Unit
 Stored Gas Inflator	 Support Cylinder for Hood	 12V Battery
 Seatbelt Tensioner or Pretensioner	 Fuel Tank	 High-Voltage Power Cable
 High-Voltage Battery	 Emergency Disconnect (Cut Cable)	

For towing and post-incident instructions, see the **POST-INCIDENT** section on page 20.



2014



VEHICLE INFORMATION

Li-ion

See pages 15, 22.

IMMOBILIZE VEHICLE

1. **Chock the wheels.**
2. **Set parking brake.**
(hand brake, center console)
3. **Place vehicle into park.**
(center console)

DISABLE VEHICLE

PRIMARY PROCEDURE

1. If ON, turn vehicle off by pressing START/STOP button for 3 seconds (right of steering column). Remove the proximity key at least 20 feet from vehicle.
2. Locate the 12V battery (driver side, engine compartment) and cut the negative cable.

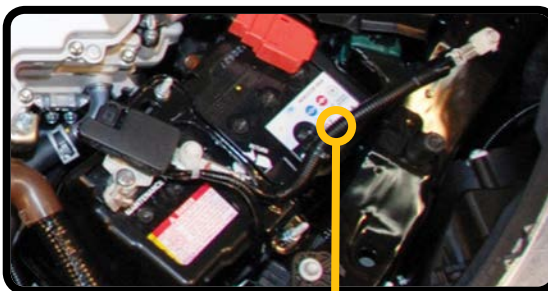

Cut Negative 12V Battery Cable

ALTERNATE PROCEDURE

1. Locate the 12V battery and cut the negative cable.
2. Cut the cable that connects the fuse box to the DC to DC Converter.

NOTE: If cutting the DC to DC Converter Cable, do not allow the cutting tool to contact any surrounding metal parts; electrical arcing could occur.



Main Fuse Box Locations

ALTERNATE PROCEDURE 2

1. Locate the 12V battery and cut the negative cable.
2. Locate the underhood fuse box, and remove the cover. Remove the main fuse using a phillips screwdriver.



Cut Cable and Main Fuse Screw Locations

WARNINGS (continued on the next page)



NEVER cut, breach, or touch orange high voltage components or cabling. Doing so could result in serious injury or death.



Airbag capacitors have a 3 minute deactivation time after disconnecting 12V power. During this time, the airbag system remains active and the potential for unintentional deployment exists. Do not cut into the center of steering wheel or dashboard airbag storage, and if cutting into the C pillar, identify the location of the airbag inflators prior to making any cuts.



In the event of a fire involving a charging station, reference the **FIRE** portion of this guide, and treat it as an energized electrical fire until power to the charger can be shut down.

HONDA ACCORD PLUG-IN

HONDA



2014



HONDA ACCORD PLUG-IN

Li-ion (continued) **EXTRICATION INFORMATION**

See pages 15, 22.

WARNINGS (continued)

Lack of engine noise does not mean vehicle is OFF. Silent movement or instant restart capability exists until vehicle is fully shut down.

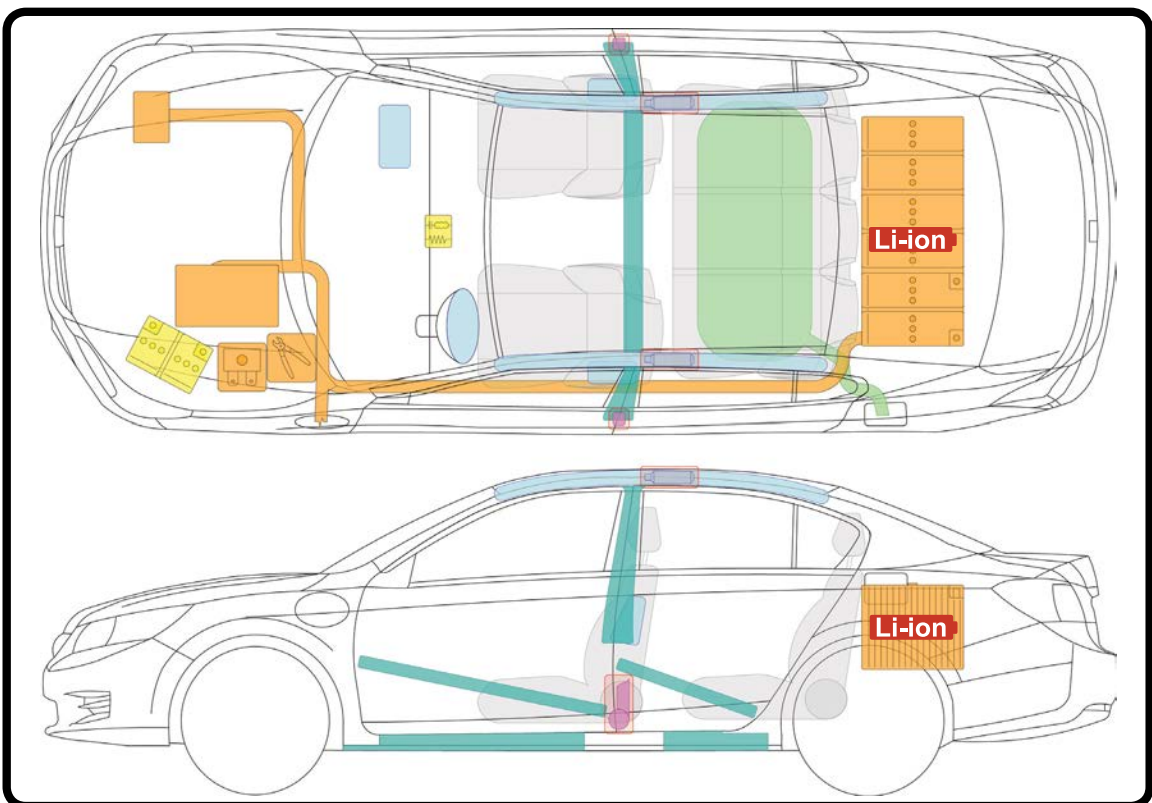

LEGEND		
Airbag	Bodywork Reinforcements	SRS Control Unit
Stored Gas Inflator	Support Cylinder for Hood	12V Battery
Seatbelt Tensioner or Pretensioner	Fuel Tank	High-Voltage Power Cable
High-Voltage Battery	Emergency Disconnect (Remove Fuse)	Emergency Disconnect (Cut Cable)

For towing and post-incident instructions, see the **POST-INCIDENT** section on page 20.



2003-05



VEHICLE INFORMATION

IMMOBILIZE VEHICLE

- 1. **Chock the wheels.**
- 2. **Set parking brake.**
(hand brake, center console)
- 3. **Place vehicle into park.**
(center console)

DISABLE VEHICLE

PRIMARY PROCEDURE

- 1. If ON, turn the vehicle's ignition off (key, steering column). Remove key.
- 2. Cut both negative cables on the 12V battery (engine compartment, driver's side front).

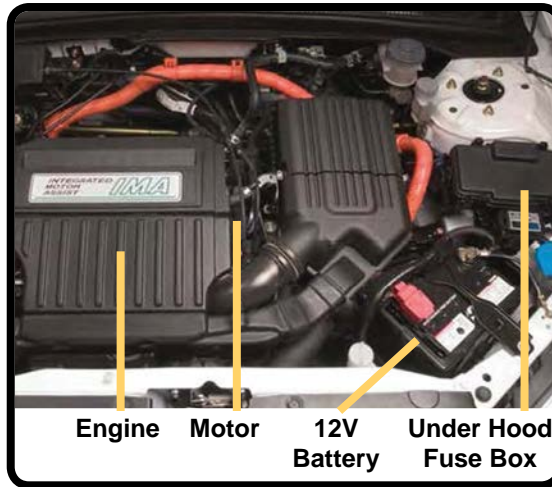

12V Battery Location



ALTERNATE PROCEDURE

- 1. Cut both negative cables on the 12V battery (engine compartment, driver's side front).
- 2. Remove main fuse (underhood fuse box, driver's side).



Main Fuse Screw Locations

WARNINGS

-  NEVER cut, breach, or touch orange high voltage components or cabling. Doing so could result in serious injury or death.
-  Airbag capacitors have a 3 minute deactivation time after disconnecting 12V power. During this time, the airbag system remains active and the potential for unintentional deployment exists. Do not cut into the center of steering wheel or dashboard airbag storage, and if cutting into the C pillar, identify the location of the airbag inflators prior to making any cuts.
-  Lack of engine noise does not mean vehicle is OFF. Silent movement or instant restart capability exists until vehicle is fully shut down.

HONDA

CIVIC

HONDA

HEV



2003-05



(continued) **EXTRICATION INFORMATION**

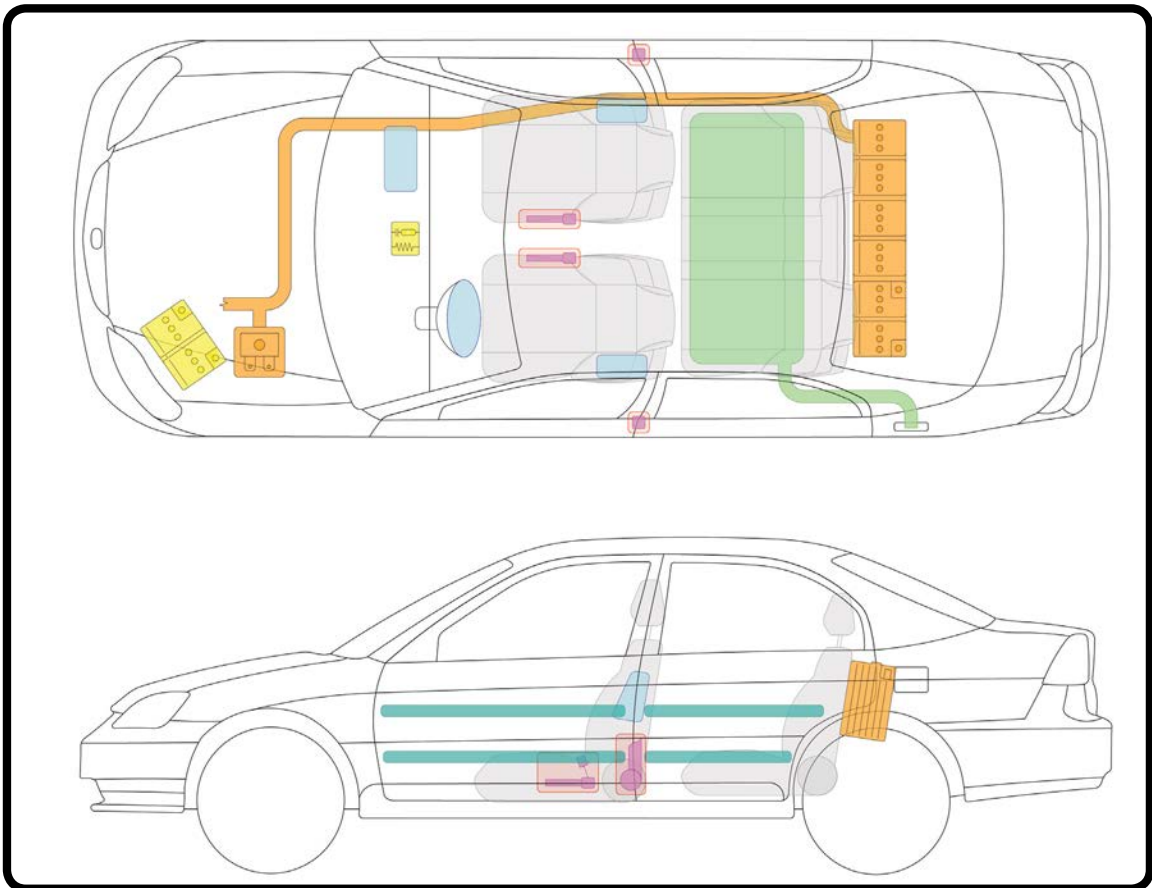

LEGEND		
Airbag	Bodywork Reinforcements	SRS Control Unit
Stored Gas Inflator	Support Cylinder for Hood	12V Battery
Seatbelt Tensioner or Pretensioner	Fuel Tank	High-Voltage Power Cable
High-Voltage Battery	Emergency Disconnect (Remove Fuse)	

For towing and post-incident instructions, see the **POST-INCIDENT** section on page 20.

HONDA
CIVIC



2006-11



VEHICLE INFORMATION

IMMOBILIZE VEHICLE

1. **Chock the wheels.**
2. **Set parking brake.**
(hand brake, center console)
3. **Place vehicle into park.**
(center console)

DISABLE VEHICLE

PRIMARY PROCEDURE

1. If ON, turn the vehicle's ignition off (key, steering column). Remove key.
2. Cut both negative cables on the 12V battery (engine compartment, driver's side front).

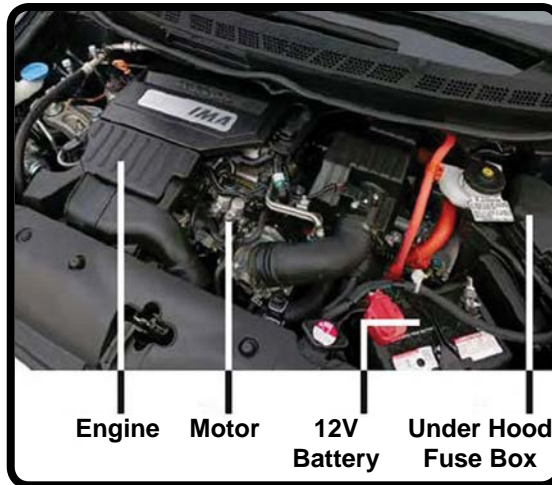

12V Battery Location



ALTERNATE PROCEDURE

1. Cut both negative cables on the 12V battery (engine compartment, driver's side front).
2. Remove main fuse (underhood fuse box, driver's side).



Main Fuse Screw Locations

WARNINGS

-  NEVER cut, breach, or touch orange high voltage components or cabling. Doing so could result in serious injury or death.
-  Airbag capacitors have a 3 minute deactivation time after disconnecting 12V power. During this time, the airbag system remains active and the potential for unintentional deployment exists. Do not cut into the center of steering wheel or dashboard airbag storage, and if cutting into the C pillar, identify the location of the airbag inflators prior to making any cuts.
-  Lack of engine noise does not mean vehicle is OFF. Silent movement or instant restart capability exists until vehicle is fully shut down.

HONDA

CIVIC

HONDA

HEV











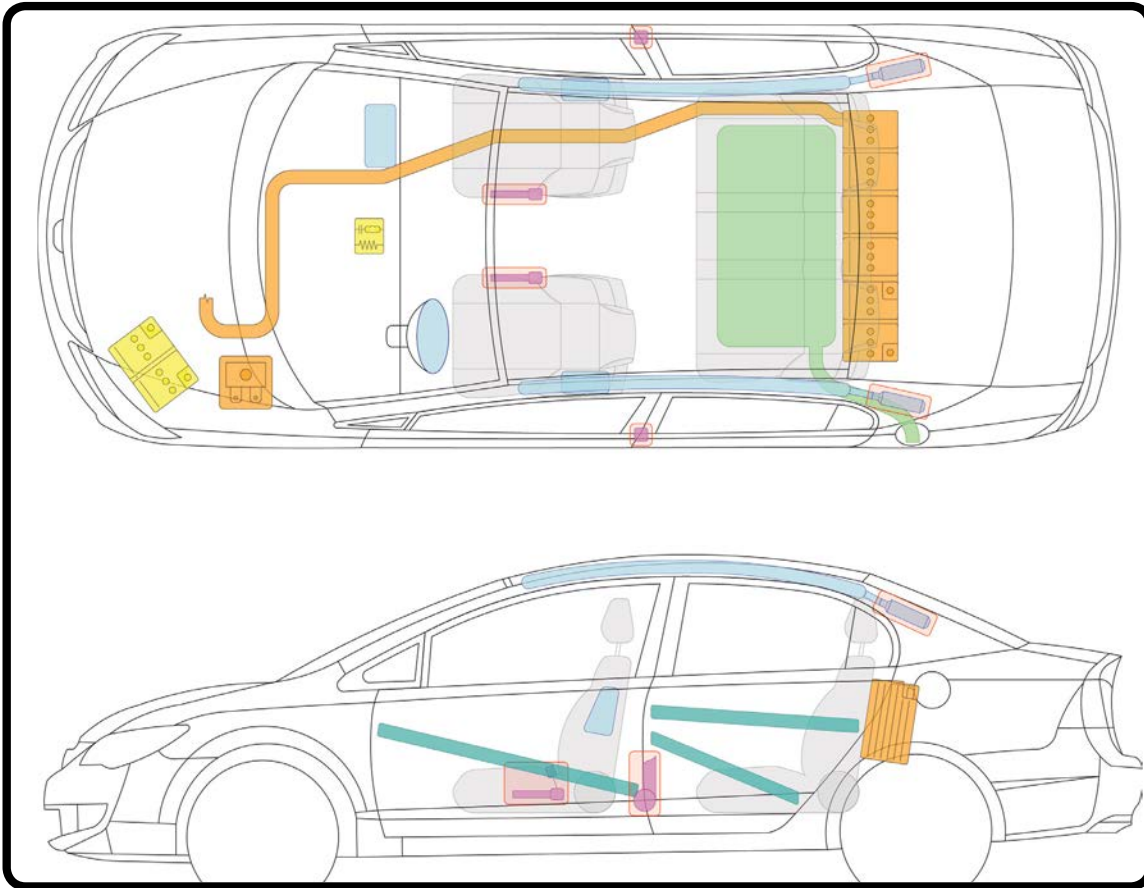

2006-11

HYBRID

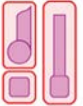

(continued) **EXTRICATION INFORMATION**

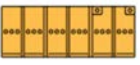

LEGEND		
 Airbag	 Bodywork Reinforcements	 SRS Control Unit
 Stored Gas Inflator	 Support Cylinder for Hood	 12V Battery
 Seatbelt Tensioner or Pretensioner	 Fuel Tank	 High-Voltage Power Cable
 High-Voltage Battery	 Emergency Disconnect (Remove Fuse)	

For towing and post-incident instructions, see the **POST-INCIDENT** section on page 20.

HONDA
CIVIC



2012-15



VEHICLE INFORMATION

Li-ion

See pages 15, 22.

IMMOBILIZE VEHICLE

1. **Chock the wheels.**
2. **Set parking brake.**
(hand brake, center console)
3. **Place vehicle into park.**
(gear lever, center console)

DISABLE VEHICLE

PRIMARY PROCEDURE

1. If ON, turn the vehicle's ignition off (key, steering column). Remove key.
2. Cut both negative cables on the 12V battery (engine compartment, driver's side front).

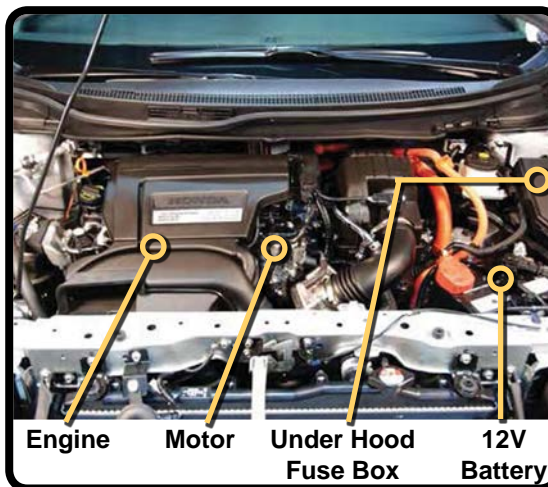

12V Battery Location

ALTERNATE PROCEDURE

(if ignition is inaccessible)

1. Cut both negative cables on the 12V battery (engine compartment, driver's side front).
2. Remove main fuse (underhood fuse box, driver's side).

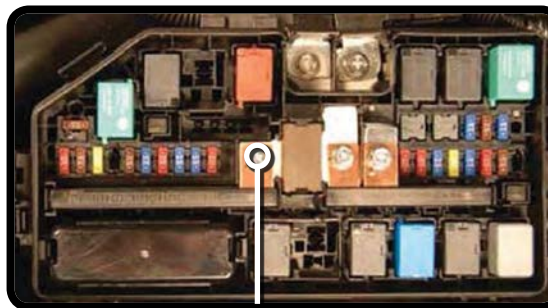

Main Fuse Screw Location

WARNINGS



NEVER cut, breach, or touch orange high voltage components or cabling. Doing so could result in serious injury or death.



Airbag capacitors have a 3 minute deactivation time after disconnecting 12V power. During this time, the airbag system remains active and the potential for unintentional deployment exists. Do not cut into the center of steering wheel or dashboard airbag storage, and if cutting into the C pillar, identify the location of the airbag inflators prior to making any cuts.



Lack of engine noise does not mean vehicle is OFF. Silent movement or instant restart capability exists until vehicle is fully shut down.

HONDA CIVIC

HONDA

HEV



2012-15







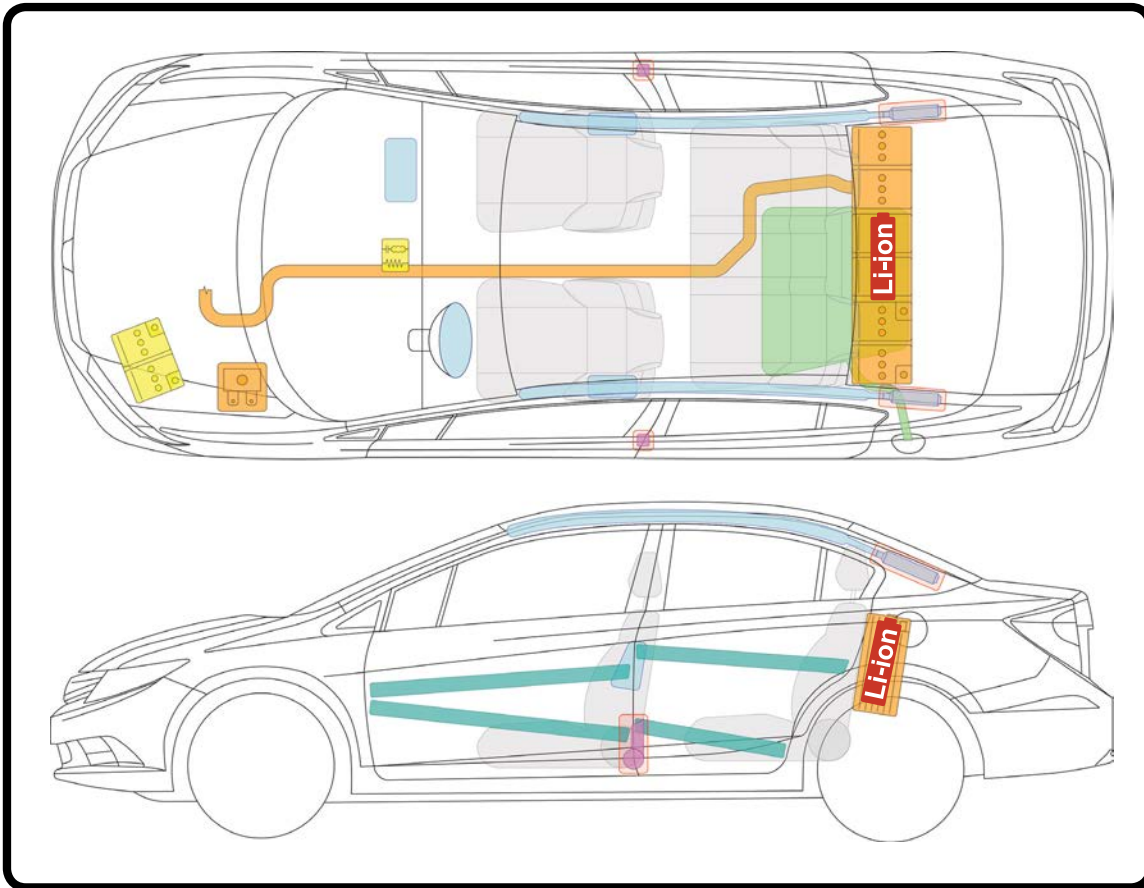

HYBRID

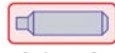

Li-ion (continued) **EXTRICATION INFORMATION**

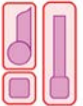
See pages 15, 22.



LEGEND		
 Airbag	 Bodywork Reinforcements	 SRS Control Unit
 Stored Gas Inflator	 Support Cylinder for Hood	 12V Battery
 Seatbelt Tensioner or Pretensioner	 Fuel Tank	 High-Voltage Power Cable
 High-Voltage Battery	 Emergency Disconnect (Remove Fuse)	

For towing and post-incident instructions, see the **POST-INCIDENT** section on page 20.

HONDA CIVIC



1998-2000



NGV

VEHICLE INFORMATION



See page 25.

IMMOBILIZE VEHICLE

1. **Chock the wheels.**
2. **Set parking brake.**
(hand brake, center console)
3. **Place vehicle into park.**
(center console)

DISABLE VEHICLE

PRIMARY PROCEDURE

1. If ON, turn the vehicle's ignition off (key, steering column). Remove key.
2. Cut the negative cable on the 12V battery (engine compartment, passenger's side).

ALTERNATE PROCEDURE

1. Remove main fuse (underhood fuse box, passenger's side).
2. Cut the negative cable on the 12V battery (engine compartment, passenger's side).

ALTERNATE PROCEDURE 2

1. Cut the negative cable on the 12V battery (engine compartment, passenger's side).
2. Turn off the CNG manual shutoff valve (inside driver's side rear wheel well).

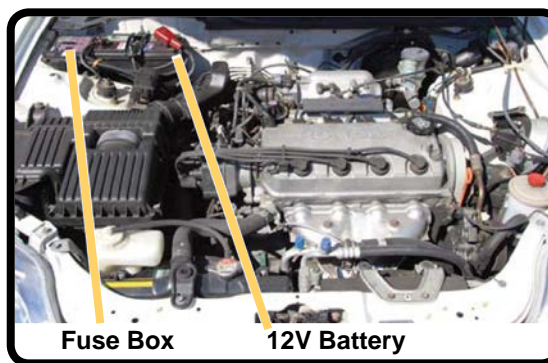

Fuse Box 12V Battery

Fuse Box and 12V Battery Location



Main Fuse Screws



Manual Shutoff Valve

WARNINGS

- Compressed Natural Gas (CNG) fuel is flammable. In case of a natural gas fire, stop the fuel flow and extinguish flames.
- Do NOT cut the fuel lines, cutting fuel lines will release the natural gas in the fuel lines.
- Do NOT try to stop a leak by over-tightening any fitting or isolation valve.
- The SRS system (airbags, etc.) may remain powered for up to 3 minutes after disabling.
- Natural gas becomes flammable at concentrations between 5% and 15% in air.

HONDA CIVIC GX

HONDA

CNG



1998-2000

NGV



HONDA CIVIC GX



See page 25.

(continued)

EXTRICATION INFORMATION

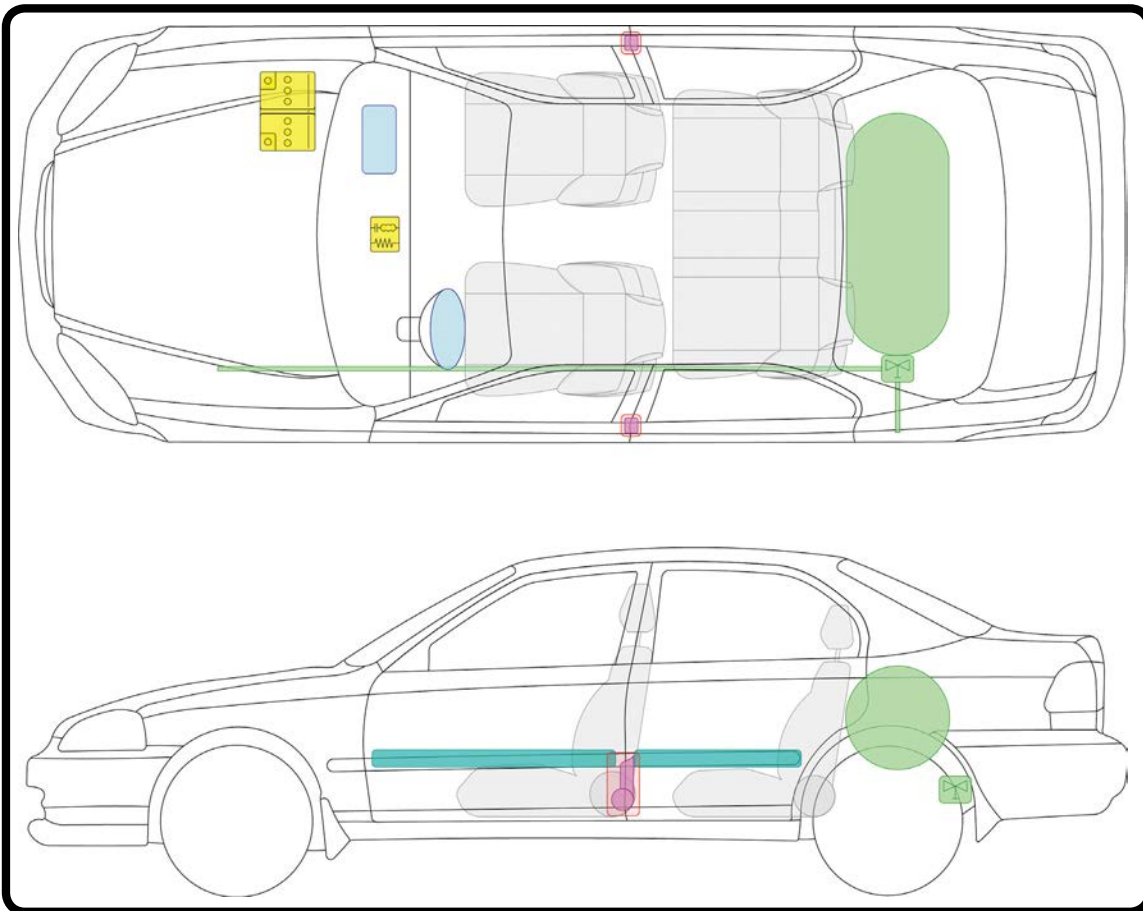

LEGEND

	Airbag		Bodywork Reinforcements		SRS Control Unit
					12V Battery
	Seatbelt Tensioner or Pretensioner		Fuel Tank		Pressure Relief Valve

For towing and post-incident instructions, see the **POST-INCIDENT** section on page 20.



2001-05



NGV

VEHICLE INFORMATION

 See page 25.

IMMOBILIZE VEHICLE

1. **Chock the wheels.**
2. **Set parking brake.**
(hand brake, center console)
3. **Place vehicle into park.**
(center console)

DISABLE VEHICLE

PRIMARY PROCEDURE

1. If ON, turn the vehicle's ignition off (key, steering column). Remove key.
2. Cut the negative cable on the 12V battery (engine compartment, passenger's side front).

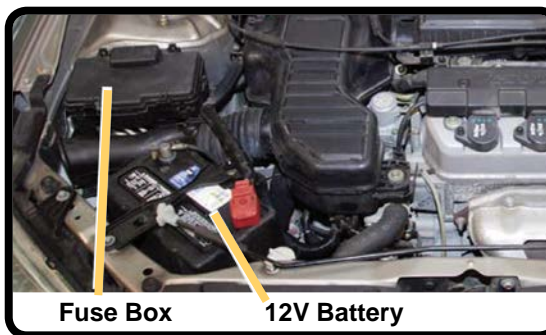

Fuse Box 12V Battery

Fuse Box and 12V Battery Location

ALTERNATE PROCEDURE

1. Remove main fuse (underhood fuse box, passenger's side front).
2. Cut the negative cable on the 12V battery (engine compartment, passenger's side front).

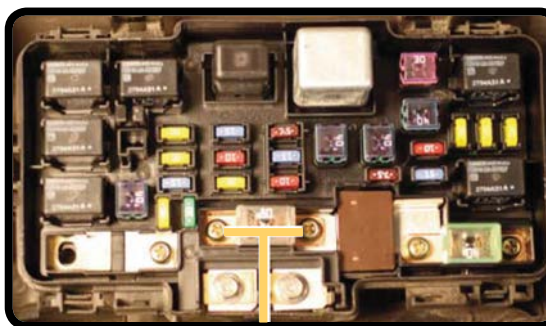

Main Fuse Screws

ALTERNATE PROCEDURE 2

1. Cut the negative cable on the 12V battery (engine compartment, passenger's side front).
2. Turn off the CNG manual shutoff valve (inside driver's side rear wheel well).

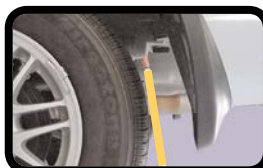





Manual Shutoff Valve



Manual Shutoff Valve

WARNINGS

-  Compressed Natural Gas (CNG) fuel is flammable. In case of a natural gas fire, stop the fuel flow and extinguish flames.
-  Do NOT cut the fuel lines, cutting fuel lines will release the natural gas in the fuel lines.
-  Do NOT try to stop a leak by over-tightening any fitting or isolation valve.
-  The SRS system (airbags, etc.) may remain powered for up to 3 minutes after disabling.
-  Natural gas becomes flammable at concentrations between 5% and 15% in air.

HONDA CIVIC GX

HONDA



2001-05

NGV



See page 25.

(continued)

EXTRICATION INFORMATION

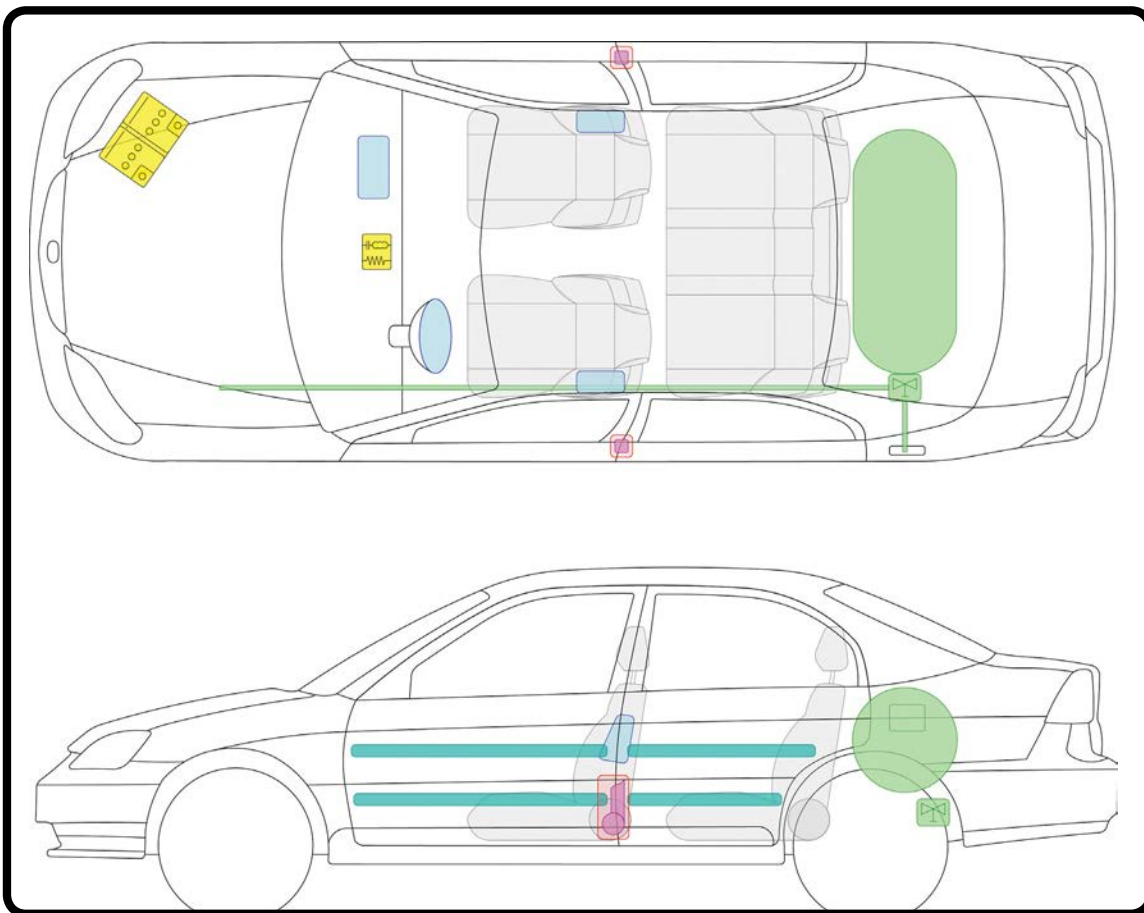

LEGEND

	Airbag		Bodywork Reinforcements		SRS Control Unit
					12V Battery
	Seatbelt Tensioner or Pretensioner		Fuel Tank		Pressure Relief Valve

For towing and post-incident instructions, see the **POST-INCIDENT** section on page 20.



2006-11



NGV
NATURAL GAS VEHICLE

VEHICLE INFORMATION

CNG
See page 25.

IMMOBILIZE VEHICLE

- 1. **Chock the wheels.**
- 2. **Set parking brake.**
(hand brake, center console)
- 3. **Place vehicle into park.**
(center console)

DISABLE VEHICLE

PRIMARY PROCEDURE

- 1. If ON, turn the vehicle's ignition off (key, steering column). Remove key.
- 2. Cut the negative cable on the 12V battery (engine compartment, driver's side front).

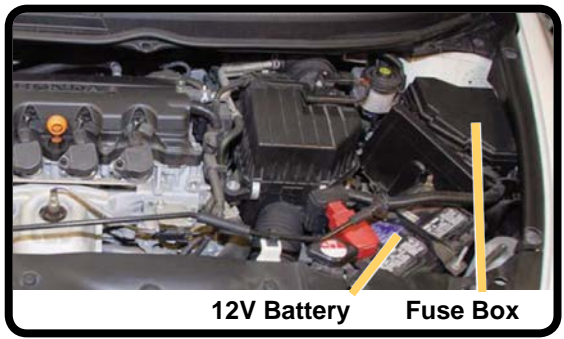

12V Battery Fuse Box
Fuse Box and 12V Battery Location

ALTERNATE PROCEDURE

- 1. Remove main fuse (underhood fuse box, driver's side front).
- 2. Cut the negative cable on the 12V battery (engine compartment, driver's side front).



Main Fuse Screws

ALTERNATE PROCEDURE 2

- 1. Cut the negative cable on the 12V battery (engine compartment, driver's side front).
- 2. Turn off the CNG manual shutoff valve (inside driver's side rear wheel well).



Manual Shutoff Valve

WARNINGS

- Compressed Natural Gas (CNG) fuel is flammable. In case of a natural gas fire, stop the fuel flow and extinguish flames.
- Do NOT cut the fuel lines, cutting fuel lines will release the natural gas in the fuel lines.
- Do NOT try to stop a leak by over-tightening any fitting or isolation valve.
- The SRS system (airbags, etc.) may remain powered for up to 3 minutes after disabling.
- Natural gas becomes flammable at concentrations between 5% and 15% in air.

HONDA CIVIC GX

HONDA

CNG



2006-11

NGV
NATURAL GAS VEHICLE



See page 25.

(continued)

EXTRICATION INFORMATION

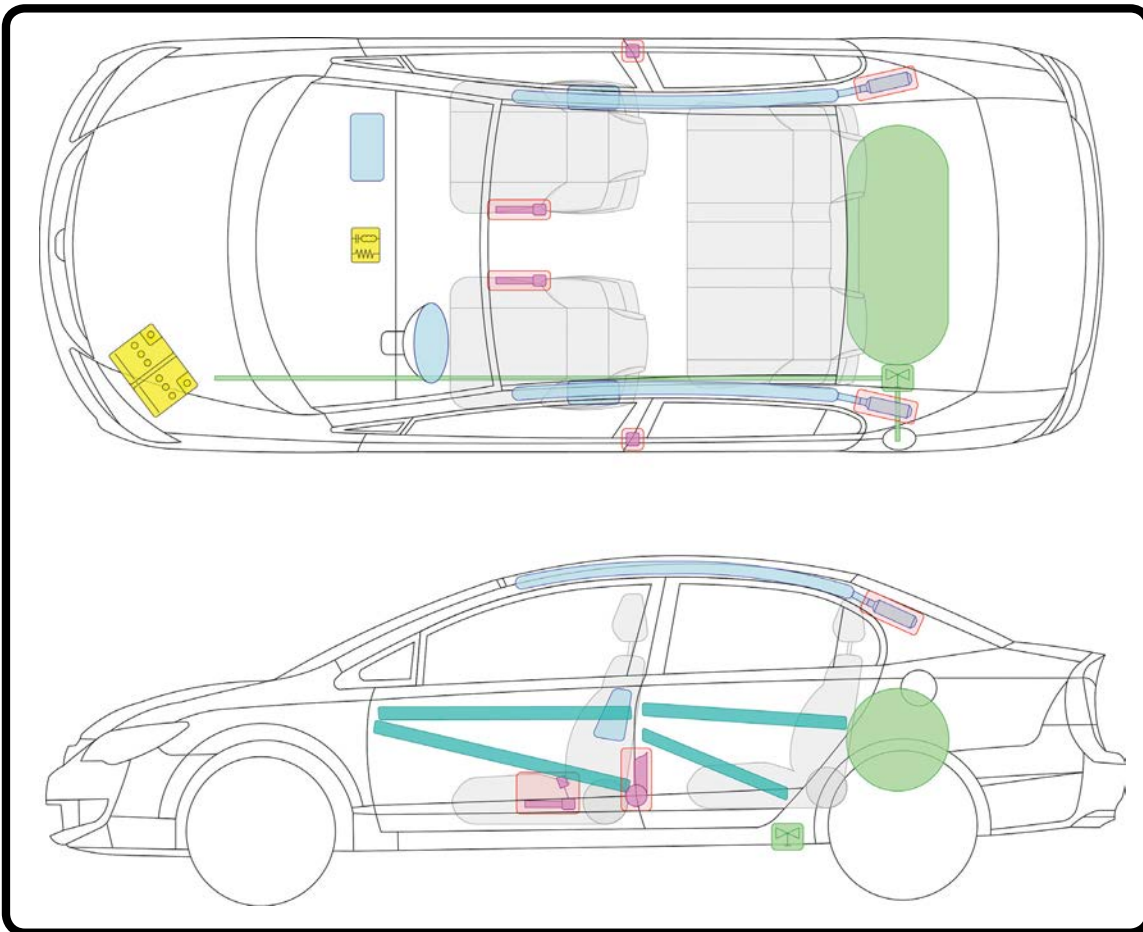

LEGEND

Airbag	Bodywork Reinforcements	SRS Control Unit
Stored Gas Inflator		12V Battery
Seatbelt Tensioner or Pretensioner	Fuel Tank	Pressure Relief Valve

For towing and post-incident instructions, see the **POST-INCIDENT** section on page 20.



2012-15



VEHICLE INFORMATION



See page 25.

IMMOBILIZE VEHICLE

1. **Chock the wheels.**
2. **Set parking brake.**
(hand brake, center console)
3. **Place vehicle into park.**
(center console)

DISABLE VEHICLE

PRIMARY PROCEDURE

1. If ON, turn the vehicle's ignition off (key, steering column). Remove key.
2. Cut the negative cable on the 12V battery (engine compartment, driver's side front).



Fuse Box and 12V Battery Location

ALTERNATE PROCEDURE

1. Remove main fuse (underhood fuse box, driver's side front).
2. Cut the negative cable on the 12V battery (engine compartment, driver's side front).

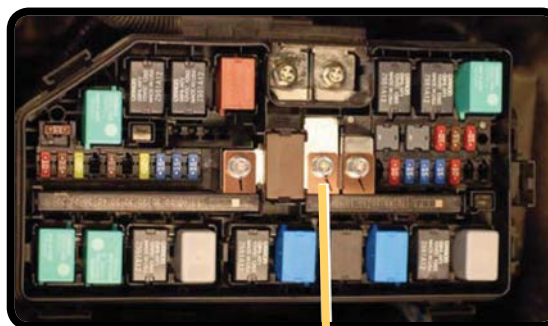

Main Fuse Screw

ALTERNATE PROCEDURE 2

1. Cut the negative cable on the 12V battery (engine compartment, driver's side front).
2. Turn off the CNG manual shutoff valve (inside driver's side rear wheel well).



Manual Shutoff Valve

WARNINGS

- Compressed Natural Gas (CNG) fuel is flammable. In case of a natural gas fire, stop the fuel flow and extinguish flames.
- Do NOT cut the fuel lines, cutting fuel lines will release the natural gas in the fuel lines.
- Do NOT try to stop a leak by over-tightening any fitting or isolation valve.
- The SRS system (airbags, etc.) may remain powered for up to 3 minutes after disabling.
- Natural gas becomes flammable at concentrations between 5% and 15% in air.

HONDA CIVIC GX

HONDA



2012-15

Natural Gas



HONDA CIVIC GX







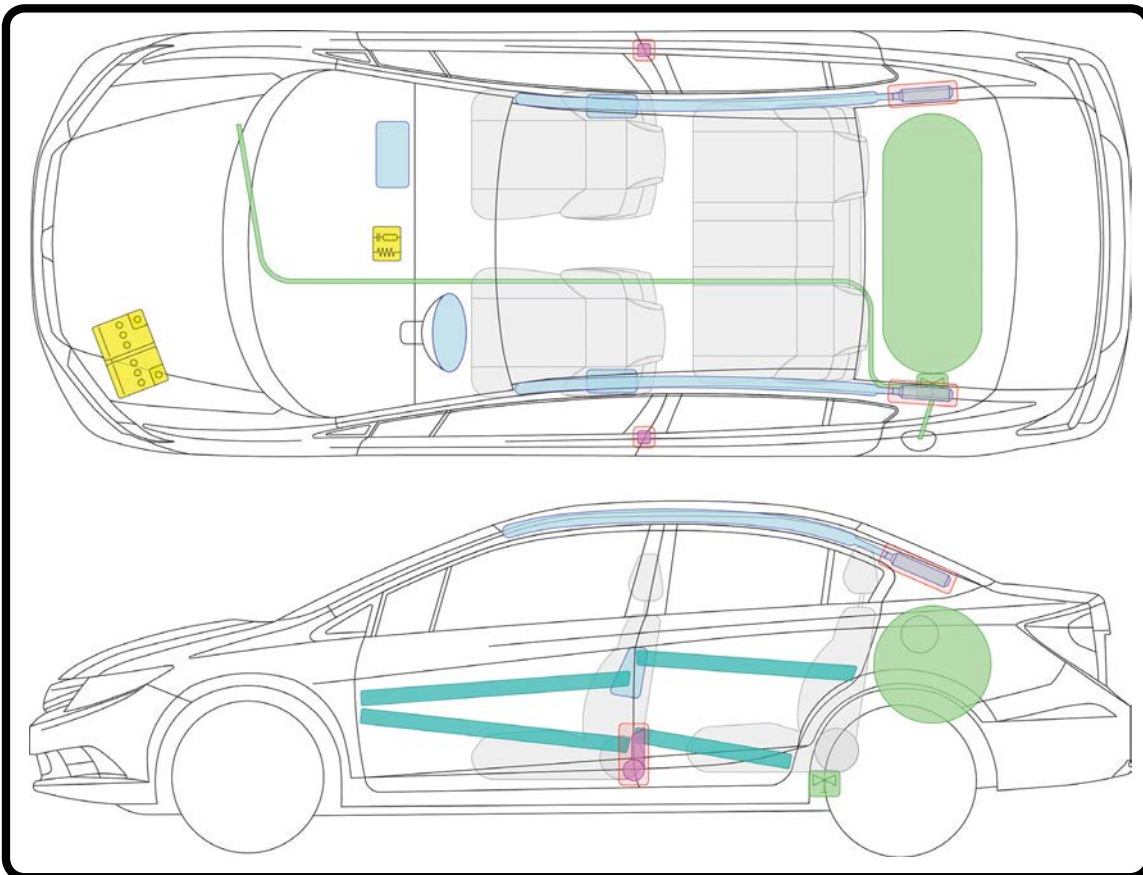

See page 25.

(continued)

EXTRICATION INFORMATION

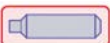

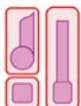
LEGEND

 Airbag	 Bodywork Reinforcements	 SRS Control Unit
 Stored Gas Inflator		 12V Battery
 Seatbelt Tensioner or Pretensioner	 Fuel Tank	 Pressure Relief Valve

For towing and post-incident instructions, see the **POST-INCIDENT** section on page 20.



2017-18



VEHICLE INFORMATION

Li-ion

See pages 15, 22.

IMMOBILIZE VEHICLE

- 1. **Chock the wheels.**
- 2. **Set parking brake.**
(push button, center console)
- 3. **Place vehicle into park.**
(push button, center console)

DISABLE VEHICLE

PRIMARY PROCEDURE

- 1. If ON, push and hold the POWER button for 3 seconds (right of steering column). Remove the proximity key at least 20 feet from vehicle.
- 2. Cut both the negative 12V battery cable and the DC to DC converter cable (engine compartment, passenger's side).



Power Button

ALTERNATE PROCEDURE

- 1. Cut both the negative 12V battery cable and the DC to DC converter cable (engine compartment, passenger's side).

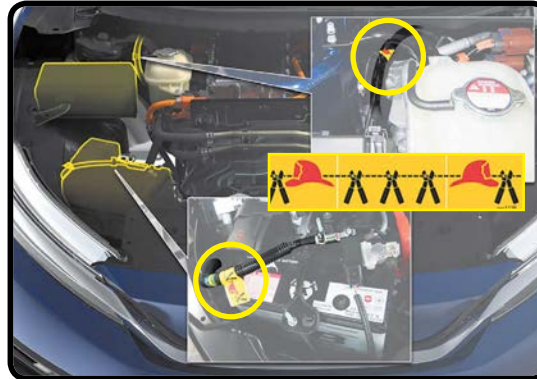

12V Negative and DC to DC Cable

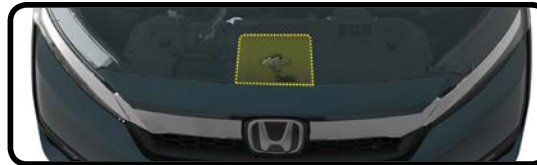

If You Need to Cut The Hood To Open It, Be Sure To Stay Within The Cut Zone

WARNINGS



NEVER cut, breach, or touch high voltage components or cabling. Doing so could result in serious injury or death.



Airbag capacitors have a 3 minute deactivation time after disconnecting 12V power. During this time, the airbag system remains active and the potential for unintentional deployment exists. Do not cut into the center of steering wheel or dashboard airbag storage, and if cutting into the C pillar, identify the location of the airbag inflators prior to making any cuts.



This vehicle does not have an internal combustion engine. Lack of engine noise does not mean vehicle is OFF. Silent movement capability exists until vehicle is fully shut down.

HONDA CLARITY

HONDA

EV











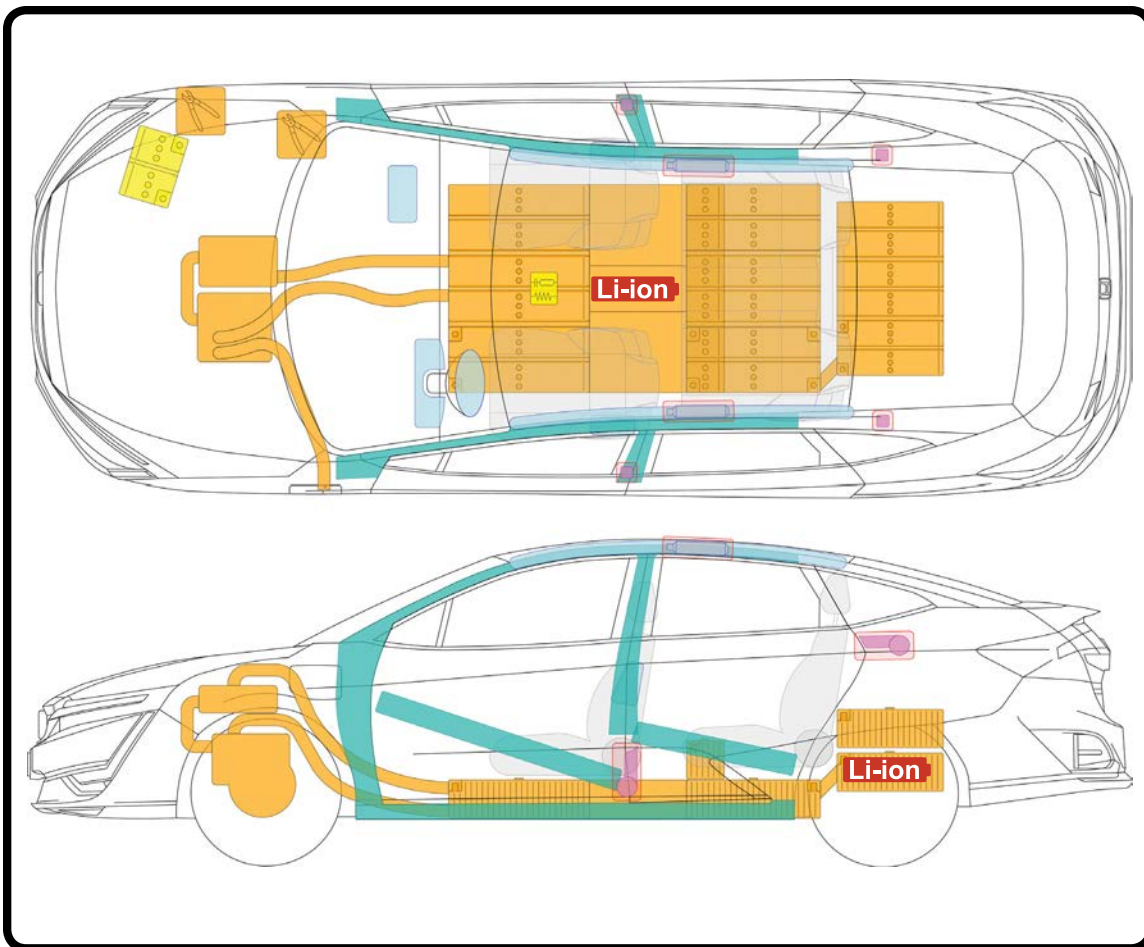

2017-18

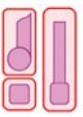

Li-ion (continued) **EXTRICATION INFORMATION**

See pages 15, 22.



LEGEND		
 Airbag	 Bodywork Reinforcements	 SRS Control Unit
 Stored Gas Inflator	 Support Cylinder for Hood	 12V Battery
 Seatbelt Tensioner or Pretensioner	 Fuel Tank	 High-Voltage Power Cable
 High-Voltage Battery		 Emergency Disconnect (Cut Cable)

For towing and post-incident instructions, see the **POST-INCIDENT** section on page 20.

HONDA CLARITY



2017-18



VEHICLE INFORMATION

Li-ion

See pages 15, 22.



See page 24.

IMMOBILIZE VEHICLE

1. **Chock the wheels.**
2. **Set parking brake.**
(push button, center console)
3. **Place vehicle into park.**
(push button, center console)

DISABLE VEHICLE

PRIMARY PROCEDURE

1. If ON, push and hold the POWER button for 3 seconds (right of steering column). Remove the proximity key at least 20 feet from vehicle.
2. Cut both the negative 12V battery cable and the DC to DC converter cable (engine compartment, passenger's side).



Power Button

ALTERNATE PROCEDURE

1. Cut both the negative 12V battery cable and the DC to DC converter cable (engine compartment, passenger's side).

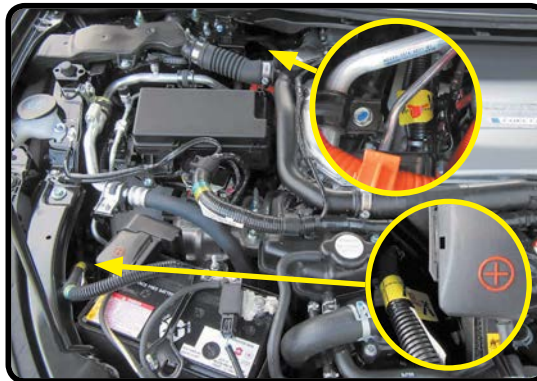

12V Negative and DC to DC Cable

SPECIAL CONCERNS

CUTTING THE HOOD OPEN

Keep the cut zone to the area immediately surrounding the hood latch.



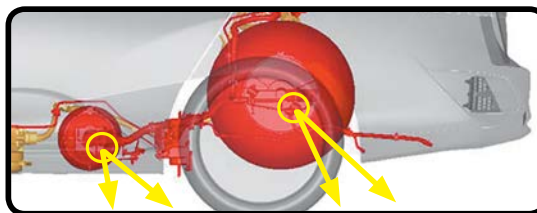

THERMALLY ACTIVATED PRESSURE RELIEF DEVICE (TPRD)

If the TPRD opens, hydrogen will be routed through a metal line and out a pressure relief tube under the trunk on the driver's side of the vehicle. The hydrogen will make a hissing noise as it escapes, until the tank is empty. It could take up to 5 minutes if the tank is full.



Thermally Activated Pressure Relief Device

WARNINGS

-  NEVER cut, breach, or touch orange high voltage components or cabling. Doing so could result in serious injury or death.
-  Turning the ignition switch OFF or disconnecting the 12V power immediately shuts down the flow of hydrogen.
-  Airbag capacitors have a 3 minute deactivation time after disconnecting 12V power. During this time, the airbag system remains active and the potential for deployment exists.
-  Fuel cell vehicles operate silently, lack of an engine noise does not mean the vehicle is OFF. Silent movement capability exists until vehicle is fully shut down.

HONDA CLARITY

HONDA



2017-18



HONDA CLARITY



See page 24.

Li-ion

See pages 15, 22.

EXTRICATION INFORMATION

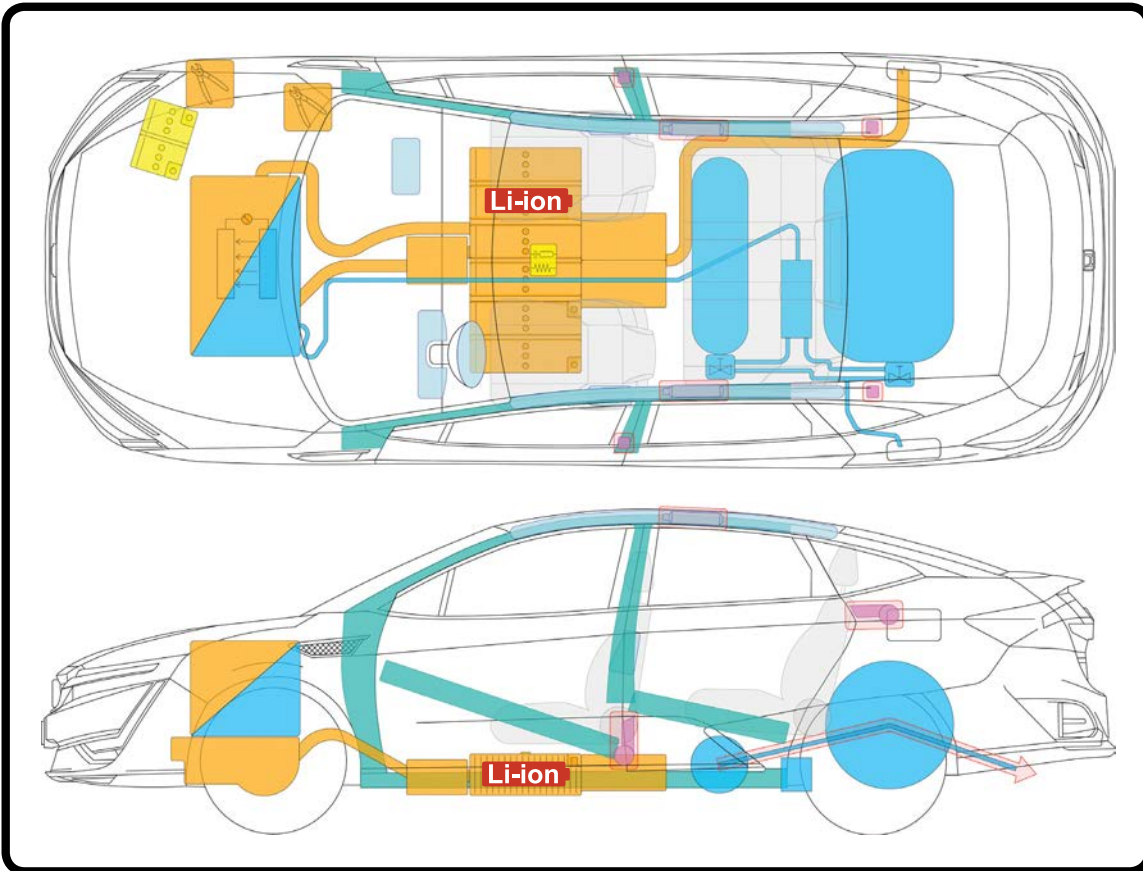

LEGEND

Airbag	Bodywork Reinforcements	SRS Control Unit
Stored Gas Inflator	Support Cylinder for Hood	12V Battery
Seatbelt Tensioner or Pretensioner	Fuel Tank	High-Voltage Power Cable
High-Voltage Battery	Emergency Disconnect (Remove Fuse)	Pressure Relief Valve

For towing and post-incident instructions, see the **POST-INCIDENT** section on page 20.



2018



VEHICLE INFORMATION

Li-ion

See pages 15, 22.

IMMOBILIZE VEHICLE

1. **Chock the wheels.**
2. **Set parking brake.**
(push button, center console)
3. **Place vehicle into park.**
(push button, center console)

DISABLE VEHICLE

PRIMARY PROCEDURE

1. If ON, push and hold the POWER button for 3 seconds (right of steering column). Remove the proximity key at least 20 feet from vehicle.
2. Cut both the negative 12V battery cable and the DC to DC converter cable (engine compartment, passenger's side).



Power Button

ALTERNATE PROCEDURE

1. Cut both the negative 12V battery cable and the DC to DC converter cable (engine compartment, passenger's side).

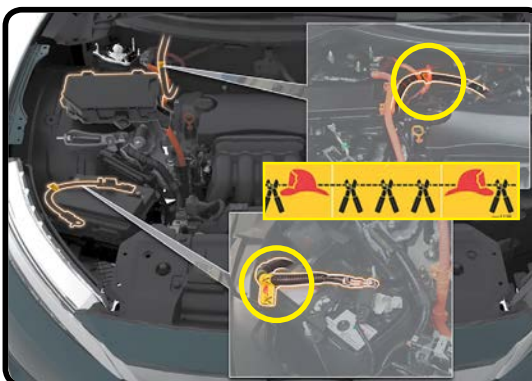

12V Negative and DC to DC Cable



If You Need to Cut The Hood To Open It, Be Sure To Stay Within The Cut Zone

WARNINGS



NEVER cut, breach, or touch high voltage components or cabling. Doing so could result in serious injury or death.



Airbag capacitors have a 3 minute deactivation time after disconnecting 12V power. During this time, the airbag system remains active and the potential for unintentional deployment exists. Do not cut into the center of steering wheel or dashboard airbag storage, and if cutting into the C pillar, identify the location of the airbag inflators prior to making any cuts.



Lack of engine noise does not mean vehicle is OFF. Silent movement or instant restart capability exists until vehicle is fully shut down.

HONDA CLARITY

HONDA



2018



HONDA CLARITY

Li-ion (continued) **EXTRICATION INFORMATION**

See pages 15, 22.

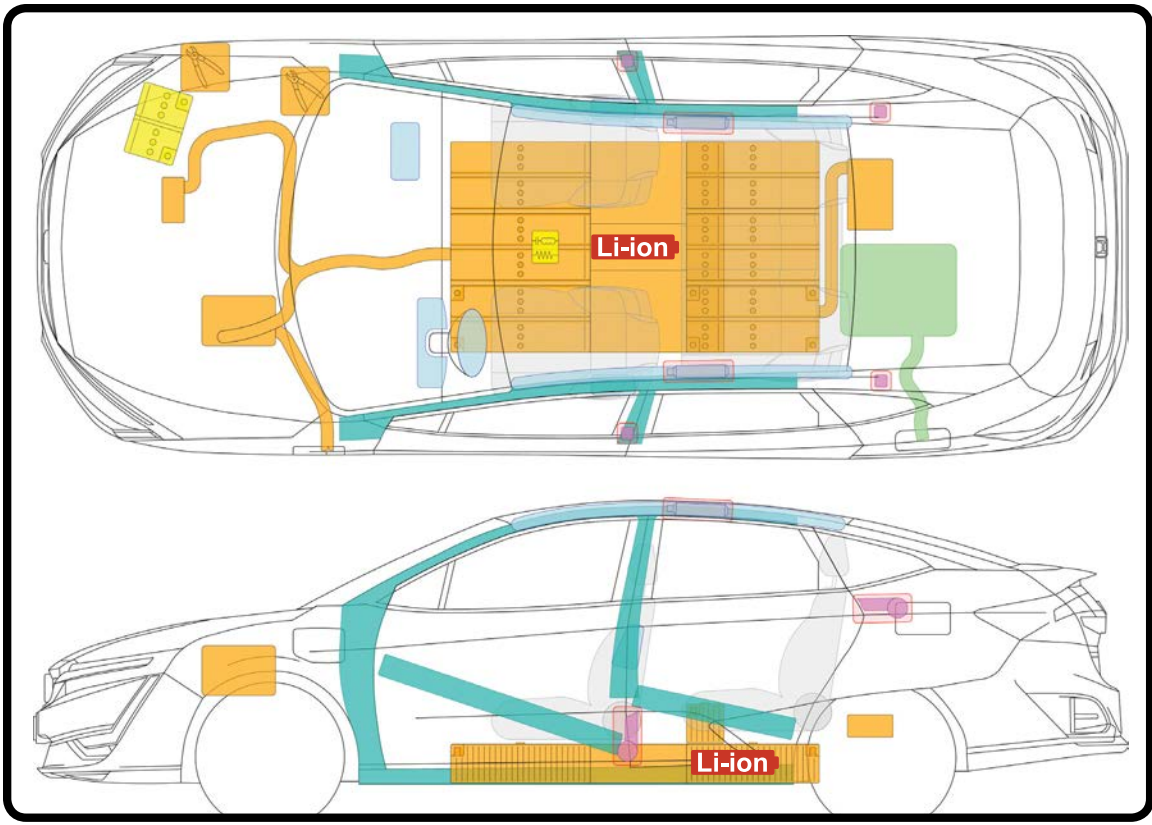

LEGEND		
Airbag	Bodywork Reinforcements	SRS Control Unit
Stored Gas Inflator	Support Cylinder for Hood	12V Battery
Seatbelt Tensioner or Pretensioner	Fuel Tank	High-Voltage Power Cable
High-Voltage Battery	Emergency Disconnect (Cut Cable)	

SUBMERSION

If the vehicle is fully or partly submerged in water you may hear noises from the battery as the cells are being discharged from shorting. First pull the vehicle out of the water. Then, shut down the high-voltage system using the procedures described on the previous pages.

For towing and post-incident instructions, see the **POST-INCIDENT** section on page 20.



2011-15

2016

2011-16



VEHICLE INFORMATION

Li-ion

2013-16 See pages 15, 22.

IMMOBILIZE VEHICLE

- 1. **Chock the wheels.**
- 2. **Set parking brake.** (hand brake, center console)
- 3. **Place vehicle into park.** (center console)
Note: CR-Z may have a manual transmission.

DISABLE VEHICLE

PRIMARY PROCEDURE

- 1. If ON, turn the vehicle's ignition off (key, steering column). Remove key.
- 2. Cut both negative cables on the 12V battery (engine compartment, driver's side front).



Positive Battery Terminal

ALTERNATE PROCEDURE

- 1. Cut both negative cables on the 12V battery (engine compartment, driver's side front).
- 2. Locate the positive battery terminal and remove the cover.
- 3. Cut or disconnect the DC to DC converter cable.



DC to DC Converter Connection

NOTE: Lithium ion batteries are used in the 2013-16 model year and up. See pages 15, 22.

WARNINGS



NEVER cut, breach, or touch high voltage components or cabling. Doing so could result in serious injury or death.



Airbag capacitors have a 3 minute deactivation time after disconnecting 12V power. During this time, the airbag system remains active and the potential for unintentional deployment exists. Do not cut into the center of steering wheel or dashboard airbag storage, and if cutting into the C pillar, identify the location of the airbag inflators prior to making any cuts.



Lack of engine noise does not mean vehicle is OFF. Silent movement or instant restart capability exists until vehicle is fully shut down.

HONDA

CR-Z

HONDA

HEV



2011-16

HYBRID



2016



2011-15

Li-ion (continued)

2013-16 See pages 15, 22.

EXTRICATION INFORMATION

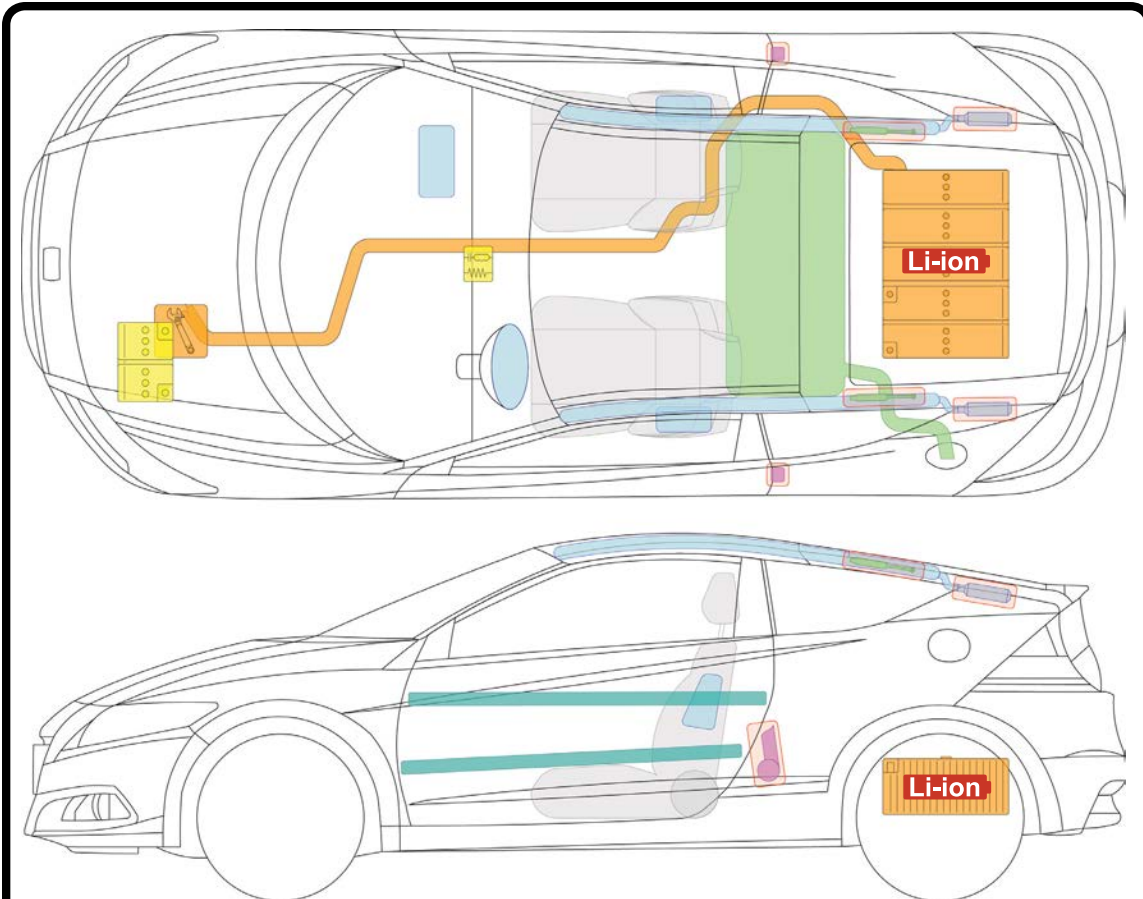

NOTE: Lithium ion batteries are used in the 2013-16 model year and up. See pages 15, 22.

LEGEND

	Airbag		Bodywork Reinforcements		SRS Control Unit
	Stored Gas Inflator		Support Cylinder for Hood		12V Battery
	Seatbelt Tensioner or Pretensioner		Fuel Tank		High-Voltage Power Cable
	High-Voltage Battery		Emergency Disconnect (Unscrew Connector)		

For towing and post-incident instructions, see the **POST-INCIDENT** section on page 20.

HONDA CR-Z



2013-14



VEHICLE INFORMATION

Li-ion

See pages 15, 22.

IMMOBILIZE VEHICLE

1. **Chock the wheels.**
2. **Set parking brake.** (hand brake, center console)
3. **Place vehicle into park.** (center console)

DISABLE VEHICLE

NOTE: If the vehicle is being charged, you will need to disconnect the charge cable.

PRIMARY PROCEDURE

1. If ON, turn the vehicle's ignition off (key, steering column). Remove key.
2. Locate the 12V battery under the hood and disconnect or cut the negative battery cable.

ALTERNATE PROCEDURE

1. Locate the 12V battery under the hood and disconnect or cut the negative battery cable.
2. Disconnect or cut the main fuse box power supply cable that is connected to the positive battery terminal.

ALTERNATE PROCEDURE 2

1. Remove the center console by removing the three mounting screws. One screw is located in the rear storage area, the others are located on both the left and right front sides of the console.
2. Remove the metal cover by turning each of the 4 attaching clips a ¼" turn counter-clockwise.
3. Remove the access cover plug, Then remove the two access cover bolts using a 10mm wrench.
4. Move the switch to the "OFF" position.



Main Fuse Box Power Supply Cable

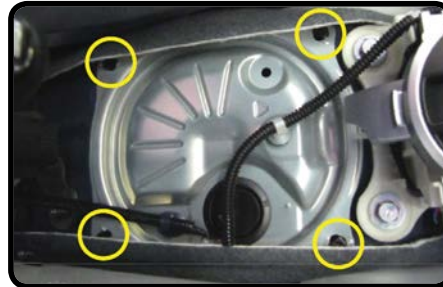

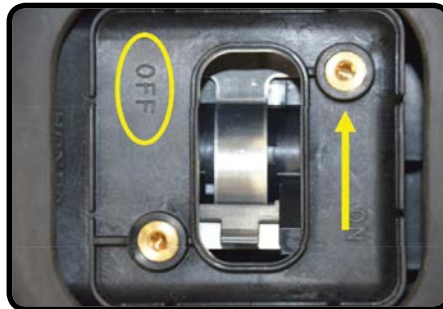

Metal Cover Under Center Console



HV System Disconnect Switch

WARNINGS (continued on the next page)

-  NEVER cut, breach, or touch orange high voltage components or cabling. Doing so could result in serious injury or death.
-  Airbag capacitors have a 3 minute deactivation time after disconnecting 12V power. During this time, the airbag system remains active and the potential for unintentional deployment exists. Do not cut into the center of steering wheel or dashboard airbag storage, and if cutting into the C pillar, identify the location of the airbag inflators prior to making any cuts.
-  In the event of a fire involving a charging station, reference the **FIRE** portion of this guide, and treat it as an energized electrical fire until power to the charger can be shut down.

HONDA FIT EV

HONDA



2013-14



Li-ion (continued) **EXTRICATION INFORMATION**

See pages 15, 22.

WARNINGS (continued)

This vehicle does not have an internal combustion engine. Lack of engine noise does not mean vehicle is OFF. Silent movement capability exists until vehicle is fully shut down

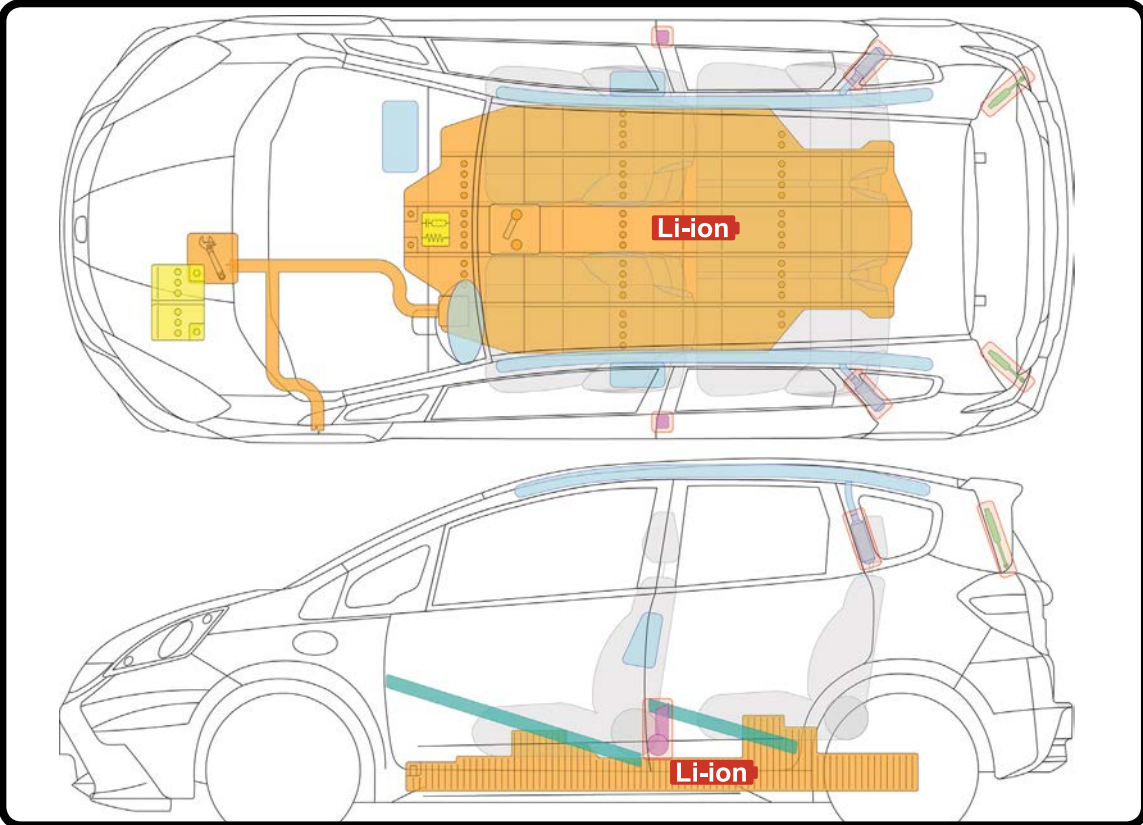

LEGEND		
Airbag	Bodywork Reinforcements	SRS Control Unit
Stored Gas Inflator	Support Cylinder for Hood	12V Battery
Seatbelt Tensioner or Pretensioner		High-Voltage Power Cable
High-Voltage Battery	Emergency Disconnect (Unscrew Connector)	Emergency Disconnect (Switch Off)

For towing and post-incident instructions, see the **POST-INCIDENT** section on page 20.

HONDA FIT EV



2000-06



VEHICLE INFORMATION

IMMOBILIZE VEHICLE

- 1. **Chock the wheels.**
- 2. **Set parking brake.**
(hand brake, center console)
- 3. **Place vehicle into park.**
(center console)

DISABLE VEHICLE

PRIMARY PROCEDURE

- 1. If ON, turn the vehicle's ignition off (key, steering column). Remove key.
- 2. Cut both negative cables on the 12V battery (engine compartment, driver's side front).

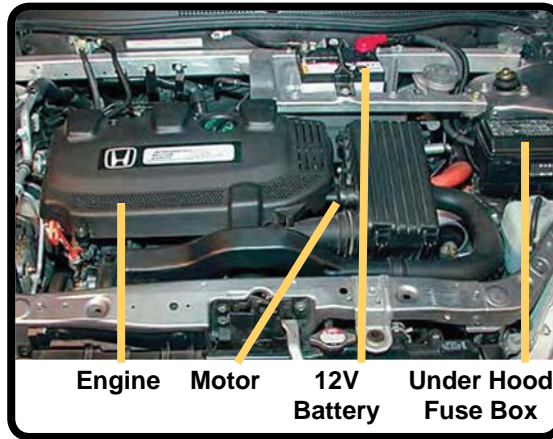

12V Battery Location

ALTERNATE PROCEDURE

- 1. Cut both negative cables on the 12V battery (engine compartment, driver's side front).
- 2. Remove main fuse (underhood fuse box, driver's side).



Main Fuse Screw Locations

WARNINGS

- NEVER cut, breach, or touch orange high voltage components or cabling. Doing so could result in serious injury or death.
- The SRS system (airbags, etc.) may remain powered for up to 3 minutes after disabling.
- Lack of engine noise does not mean vehicle is OFF. Silent movement or instant restart capability exists until vehicle is fully shut down.

HONDA

Insight

HONDA

HEV



2000-06



Insight

(continued) **EXTRICATION INFORMATION**

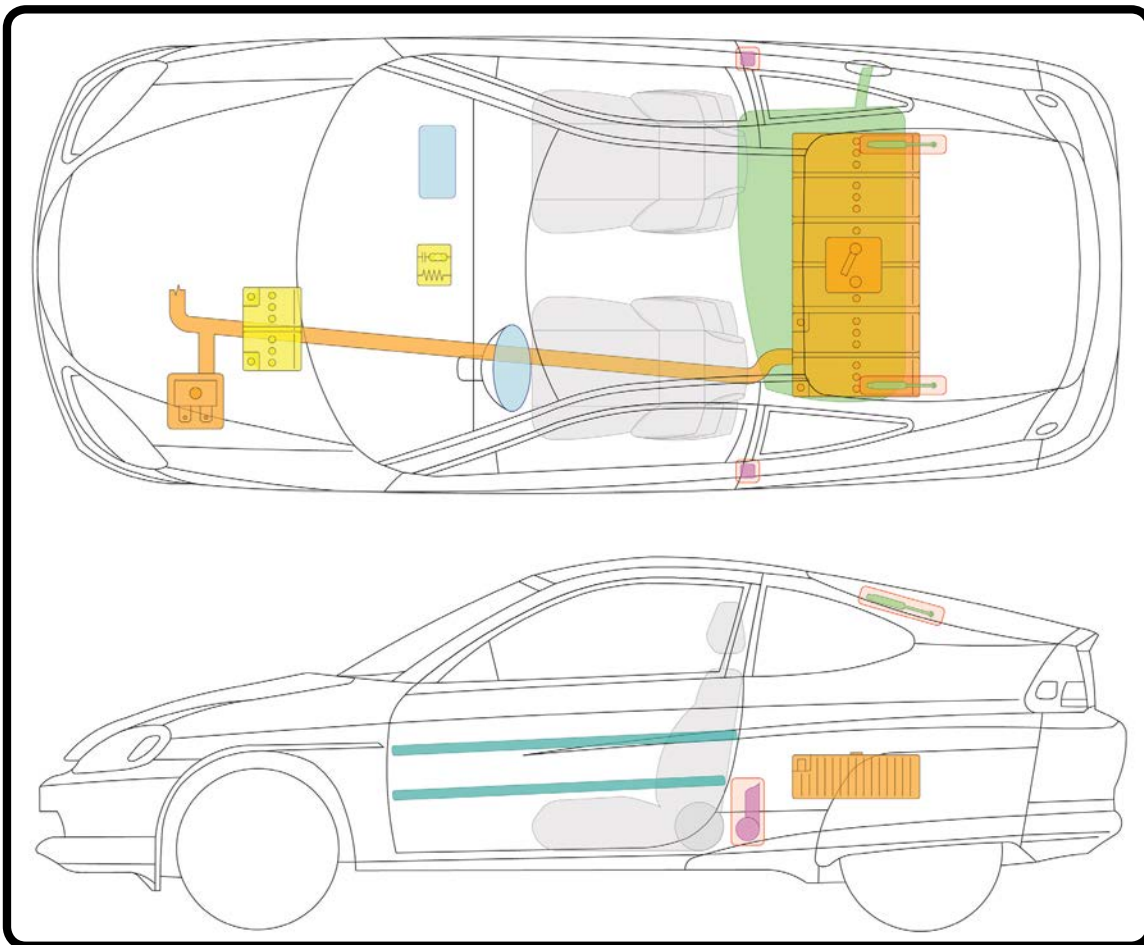

LEGEND

	Airbag		Bodywork Reinforcements		SRS Control Unit
	Stored Gas Inflator		Support Cylinder for Hood		12V Battery
	Seatbelt Tensioner or Pretensioner		Fuel Tank		High-Voltage Power Cable
	High-Voltage Battery		Emergency Disconnect (Remove Fuse)		Emergency Disconnect (Switch Off)

For towing and post-incident instructions, see the **POST-INCIDENT** section on page 20.



2010-14



VEHICLE INFORMATION

IMMOBILIZE VEHICLE

- 1. **Chock the wheels.**
- 2. **Set parking brake.**
(hand brake, center console)
- 3. **Place vehicle into park.**
(center console)

DISABLE VEHICLE

PRIMARY PROCEDURE

- 1. If ON, turn the vehicle's ignition off (key, steering column). Remove key.
- 2. Cut both negative cables on the 12V battery (engine compartment, driver's side front).



Positive Battery Terminal

ALTERNATE PROCEDURE

- 1. Cut both negative cables on the 12V battery (engine compartment, driver's side front).
- 2. Locate the positive battery terminal and remove the cover.
- 3. Cut or disconnect the DC to DC converter cable.



DC to DC Converter Connection

WARNINGS



NEVER cut, breach, or touch high voltage components or cabling. Doing so could result in serious injury or death.



Airbag capacitors have a 3 minute deactivation time after disconnecting 12V power. During this time, the airbag system remains active and the potential for unintentional deployment exists. Do not cut into the center of steering wheel, dashboard airbag storage, and if cutting into the C pillar, identify the location of the airbag inflators prior to making any cuts.



Lack of engine noise does not mean vehicle is OFF. Silent movement or instant restart capability exists until vehicle is fully shut down.

HONDA

Insight

HONDA

HEV



2010-14



Insight

(continued) **EXTRICATION INFORMATION**

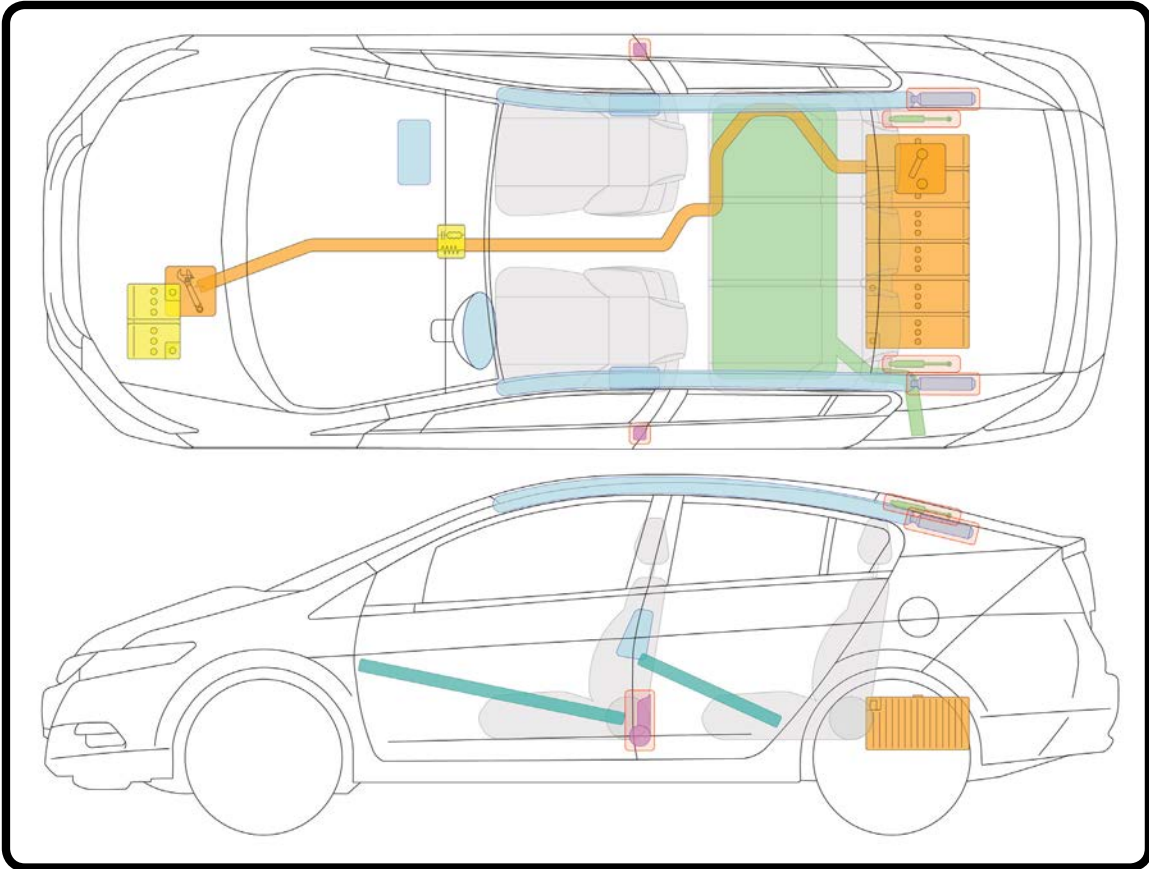

LEGEND

Airbag	Bodywork Reinforcements	SRS Control Unit
Stored Gas Inflator	Support Cylinder for Hood	12V Battery
Seatbelt Tensioner or Pretensioner	Fuel Tank	High-Voltage Power Cable
High-Voltage Battery	Emergency Disconnect (Unscrew Connector)	Emergency Disconnect (Switch Off)

For towing and post-incident instructions, see the **POST-INCIDENT** section on page 20.



2017-18



HYUNDAI

VEHICLE INFORMATION

Li-ion

See pages 15, 22.

IMMOBILIZE VEHICLE

1. **Chock the wheels.**
2. **Set parking brake.**
(push/pull button, center console)
3. **Place vehicle into park.**
(center console gear selector)

DISABLE VEHICLE

Determine if vehicle is ON, if the READY indicator is illuminated the vehicle is on.



PRIMARY PROCEDURE

1. If ON, turn vehicle off by pressing START/STOP button (right of steering column).
2. If possible, remove proximity key fob and keep it at least 6 feet (2 meters) from vehicle.
3. Disconnect 12V negative battery cable (engine compartment).
4. Remove Service Disconnect Plug (trunk).

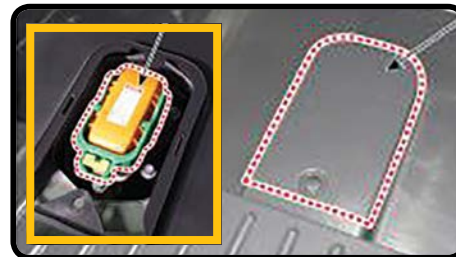

Service Disconnect Located in Trunk

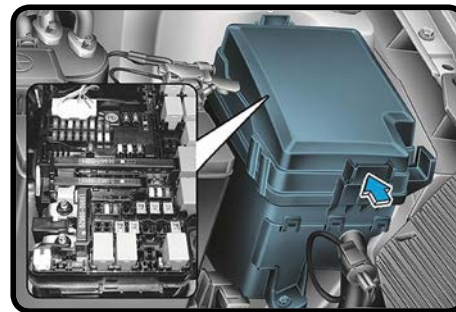

Fuse Box Location

ALTERNATE PROCEDURE

(if ignition is inaccessible)

1. Open hood and remove engine compartment fuse box cover.
2. Remove IG1, IG2 (fuse/relay). See diagram. If the correct relay cannot be identified, pull all relays and fuses in the fuse box.
3. Disconnect 12V battery (engine compartment).
4. Remove Service Disconnect Plug (trunk).

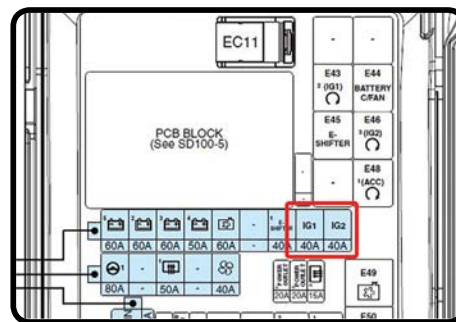

Fuse Location

NOTE: If neither of the preceding methods can be completed, emergency responders must be aware of the potential for accidental airbag activation as well as understand that the HV system may not have been shut down.

WARNINGS

- NEVER cut, breach, or touch high voltage components or cabling. Doing so could result in serious injury or death.
- The high voltage system may remain powered for up to 5 minutes after the vehicle is shut off or the service disconnect plug has been removed.
- The SRS system (airbags, etc.) may remain powered for up to 3 minutes after disabling.
- This vehicle does not have an internal combustion engine. Lack of engine noise does not mean vehicle is OFF. Silent movement capability exists until vehicle is fully shut down.

HYUNDAI

IONIQ



2017-18

electric



Li-ion (continued) **EXTRICATION INFORMATION**

See pages 15, 22.

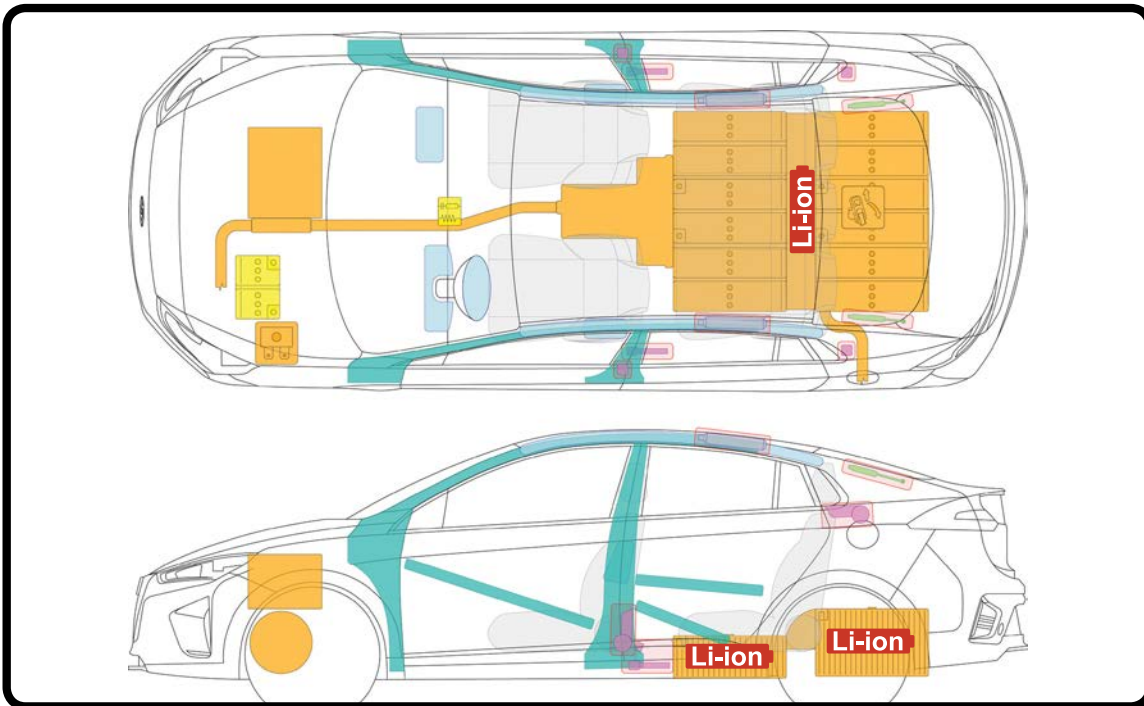

LEGEND		
Airbag	Bodywork Reinforcements	SRS Control Unit
Stored Gas Inflator	Support Cylinder for Hood	12V Battery
Seatbelt Tensioner or Pretensioner	Fuel Tank	High-Voltage Power Cable
High-Voltage Battery	Emergency Disconnect (Remove Fuse)	Emergency Disconnect (Remove Plug)

SPECIAL CONCERNS

A PLUGGED IN VEHICLE

If the vehicle is plugged in for charging, you should first unplug it. If access to unplug the vehicle is unavailable, “remove charge power” from the vehicle (done by turning off the power to the charge station).



Vehicle Charging Plug

For towing and post-incident instructions, see the **POST-INCIDENT** section on page 20.



2017-18



HYUNDAI

VEHICLE INFORMATION

Li-ion
See pages 15, 22.

IMMOBILIZE VEHICLE

1. **Chock the wheels.**
2. **Set parking brake.**
(foot pedal)
3. **Place vehicle into park.**
(center console gear selector)

DISABLE VEHICLE

Determine if vehicle is ON, if the READY indicator is illuminated the vehicle is on.



PRIMARY PROCEDURE

1. If ON, turn vehicle off by pressing START/STOP button (right of steering column).
2. If possible, remove proximity key fob and keep it at least 6 feet (2 meters) from vehicle.
3. Disconnect 12V negative battery cable (behind cover, rear wheel house trim, driver's side).
4. Remove Service Disconnect Plug (under rear right seat).

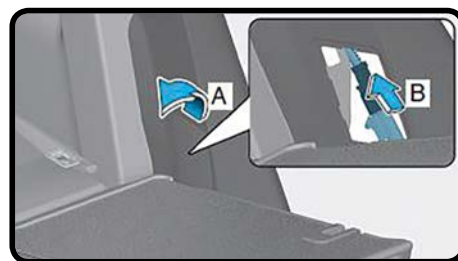

12V Disconnect Rear Wheel Trim

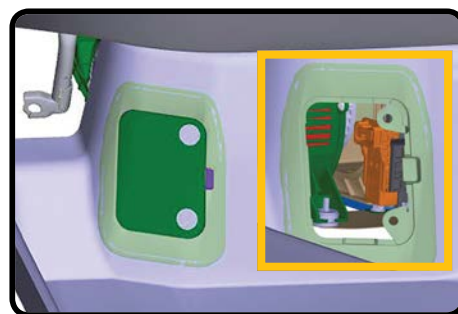

Disconnect Under Rear Right Seat

ALTERNATE PROCEDURE

(if ignition is inaccessible)

1. Open hood and remove engine compartment fuse box cover.
2. Remove IG1, IG2 (fuse/relay). See diagram. If the correct relay cannot be identified, pull all relays and fuses in the fuse box.
3. Disconnect 12V negative battery cable (behind cover, rear wheel house trim, driver's side).
4. Remove Service Disconnect Plug (under rear right seat).

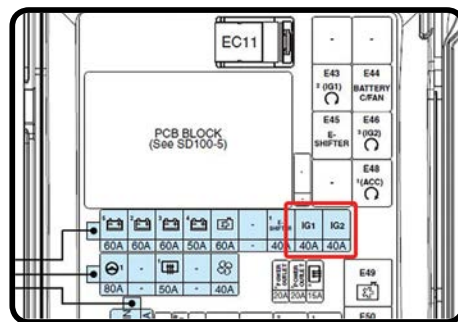

Fuse Location

NOTE: If neither method is completed, accidental airbag activation may occur and the HV system may not have been shut down.

WARNINGS

- NEVER cut, breach, or touch high voltage components or cabling. Doing so could result in serious injury or death.
- The high voltage system may remain powered for up to 5 minutes after the vehicle is shut off or the service disconnect plug has been removed.
- The SRS system (airbags, etc.) may remain powered for up to 3 minutes after disabling.
- Lack of engine noise does not mean vehicle is OFF. Silent movement or instant restart capability exists until vehicle is fully shut down.

HYUNDAI IONIQ

HEV

HYUNDAI



2017-18

hybrid



IONIQ

Li-ion (continued) **EXTRICATION INFORMATION**

See pages 15, 22.

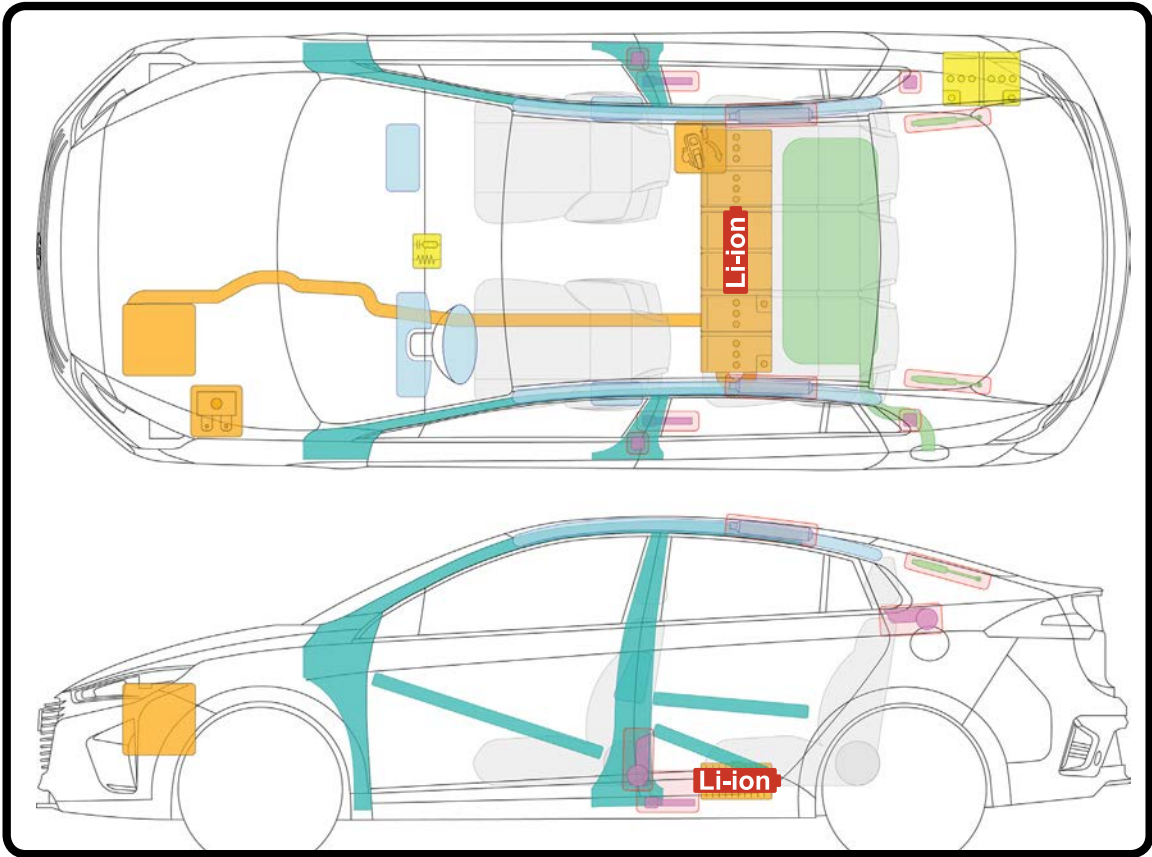

LEGEND		
	Airbag	
	Stored Gas Inflator	
	Seatbelt Tensioner or Pretensioner	
	High-Voltage Battery	
	Bodywork Reinforcements	
	Support Cylinder for Hood	

For towing and post-incident instructions, see the **POST-INCIDENT** section on page 20.

HYUNDAI



2018



HYUNDAI

HYUNDAI

IONIQ

VEHICLE INFORMATION

Li-ion

See pages 15, 22.

IMMOBILIZE VEHICLE

1. **Chock the wheels.**
2. **Set parking brake.**
(foot pedal)
3. **Place vehicle into park.**
(center console gear selector)

DISABLE VEHICLE

Determine if vehicle is ON, if the READY indicator is illuminated the vehicle is on.



PRIMARY PROCEDURE

1. If ON, turn vehicle off by pressing START/STOP button (right of steering column).
2. If possible, remove proximity key fob and keep it at least 6 feet (2 meters) from vehicle.
3. Disconnect 12V negative battery cable (trunk).
4. Remove Service Disconnect Plug (trunk).

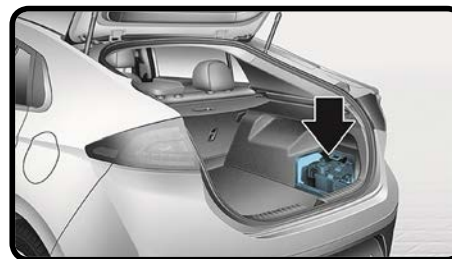

12V Battery In Trunk



Service Disconnect Located in Trunk

ALTERNATE PROCEDURE

(if ignition is inaccessible)

1. Open hood and remove engine compartment fuse box cover.
2. Remove IG1, IG2 (fuse/relay). See diagram.
If the correct relay cannot be identified, pull all relays and fuses in the fuse box.
3. Disconnect 12V battery (trunk).
4. Remove Service Disconnect Plug (trunk).

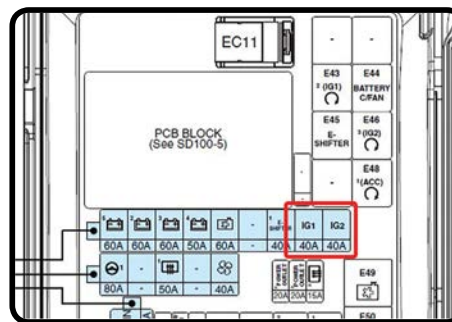

Fuse Location

NOTE: If neither of the preceding methods can be completed, emergency responders must be aware of the potential for accidental airbag activation as well as understand that the HV system may not have been shut down.

WARNINGS

- NEVER cut, breach, or touch high voltage components or cabling. Doing so could result in serious injury or death.
- The high voltage system may remain powered for up to 5 minutes after the vehicle is shut off or the service disconnect plug has been removed.
- The SRS system (airbags, etc.) may remain powered for up to 3 minutes after disabling.
- Lack of engine noise does not mean vehicle is OFF. Silent movement or instant restart capability exists until vehicle is fully shut down.



2018 plug-in









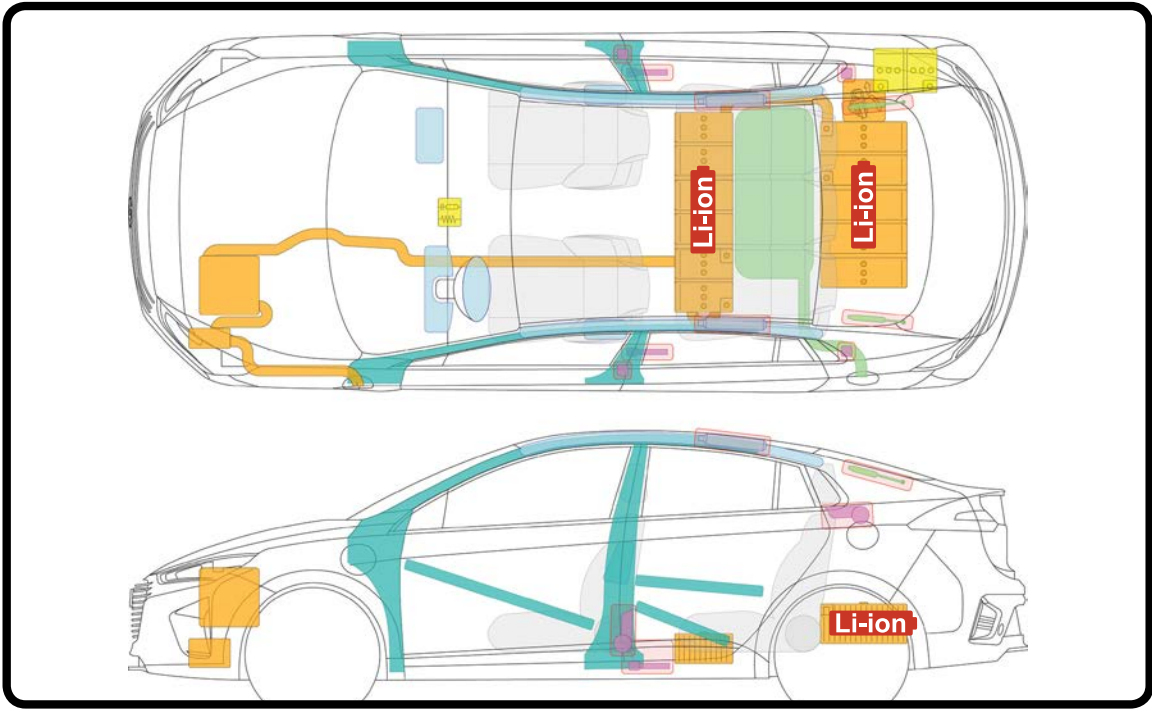

IONIQ
HYUNDAI

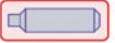
Li-ion (continued) EXTRICATION INFORMATION

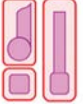
See pages 15, 22.



LEGEND		
 Airbag	 Bodywork Reinforcements	 SRS Control Unit
 Stored Gas Inflator	 Support Cylinder for Hood	 12V Battery
 Seatbelt Tensioner or Pretensioner	 Fuel Tank	 High-Voltage Power Cable
 High-Voltage Battery		 Emergency Disconnect (Remove Plug)

SPECIAL CONCERNS

A PLUGGED IN VEHICLE

If the vehicle is plugged in for charging, you should first unplug it. If access to unplug the vehicle is unavailable, “remove charge power” from the vehicle (done by turning off the power to the charge station).



Vehicle Charging Plug

For towing and post-incident instructions, see the **POST-INCIDENT** section on page 20.



2011-15



HYUNDAI

VEHICLE INFORMATION

Li-ion

See pages 15, 22.

IMMOBILIZE VEHICLE

1. Chock the wheels.
2. Set parking brake. (foot pedal)
3. Place vehicle into park. (center console gear selector)

DISABLE VEHICLE

Determine if vehicle is ON by presence of READY indicator or color of LED on START/STOP button: Blue or amber means vehicle is ON.

PRIMARY PROCEDURE

1. If ON, turn vehicle off by pressing START/STOP button (right of steering column).
2. If possible, remove proximity key fob and keep it at least 6 feet (2 meters) from vehicle.
3. Disconnect 12V battery (right side trunk).
4. Remove Service Disconnect Plug (trunk).

ALTERNATE PROCEDURE

(if ignition is inaccessible)

1. Open hood and remove engine compartment fuse box cover.
2. Remove IG1 relay (tan). See diagram. If the correct relay cannot be identified, pull all relays and fuses in the fuse box.
3. Disconnect 12V battery (right side trunk).
4. Remove Service Disconnect Plug (trunk).

NOTE: If neither of the preceding methods can be completed, emergency responders must be aware of the potential for accidental airbag activation as well as understand that the HV system may not have been shut down.



Service Disconnect Located in Trunk



Fuse Box Location



Fuse Location

WARNINGS

- NEVER cut, breach, or touch high voltage components or cabling. Doing so could result in serious injury or death.
- The high voltage system may remain powered for up to 10 minutes after the vehicle is shut off or the service disconnect plug has been removed.
- The SRS system (airbags, etc.) may remain powered for up to 3 minutes after disabling.
- Lack of engine noise does not mean vehicle is OFF. Silent movement or instant restart capability exists until vehicle is fully shut down.

HYUNDAI SONATA



2011-15

hybrid



SONATA

HYUNDAI

Li-ion (continued) **EXTRICATION INFORMATION**

See pages 15, 22.

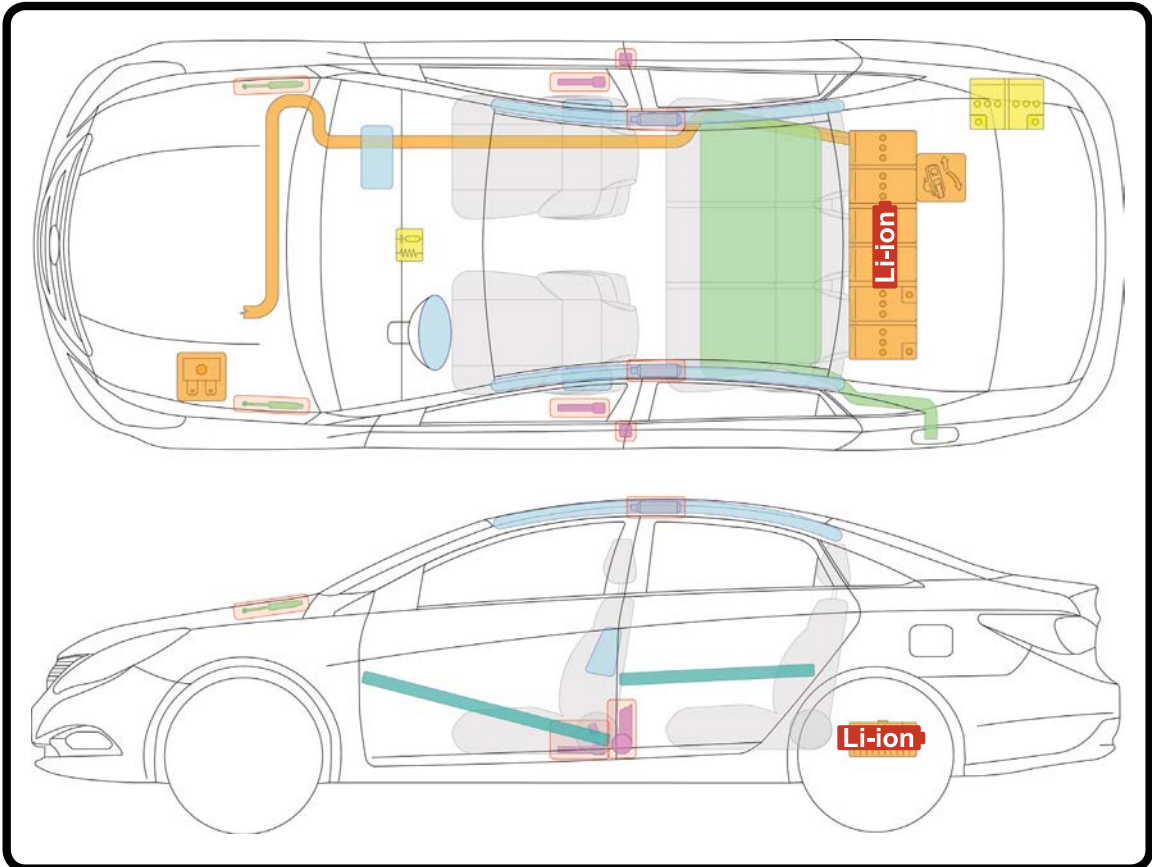

LEGEND		
Airbag	Bodywork Reinforcements	SRS Control Unit
Stored Gas Inflator	Support Cylinder for Hood	12V Battery
Seatbelt Tensioner or Pretensioner	Fuel Tank	High-Voltage Power Cable
High-Voltage Battery	Emergency Disconnect (Remove Fuse)	Emergency Disconnect (Remove Plug)

For towing and post-incident instructions, see the **POST-INCIDENT** section on page 20.



2016-18



HYUNDAI

VEHICLE INFORMATION

Li-ion

See pages 15, 22.

IMMOBILIZE VEHICLE

1. Chock the wheels.
2. Set parking brake. (foot pedal)
3. Place vehicle into park. (center console gear selector)

DISABLE VEHICLE

Determine if vehicle is ON, if the READY indicator is illuminated the vehicle is on.



PRIMARY PROCEDURE

1. If ON, turn vehicle off by pressing START/STOP button (right of steering column).
2. If possible, remove proximity key fob and keep it at least 6 feet (2 meters) from vehicle.
3. Disconnect 12V battery (passenger's side trunk).
4. Remove Service Disconnect Plug (trunk).

ALTERNATE PROCEDURE

(if ignition is inaccessible)

1. Open hood and remove engine compartment fuse box cover.
2. Remove IG1 relay. See diagram. If the correct relay cannot be identified, pull all relays and fuses in the fuse box.
3. Disconnect 12V battery (passenger's side trunk).
4. Remove Service Disconnect Plug (trunk).

NOTE: If neither of the preceding methods can be completed, emergency responders must be aware of the potential for accidental airbag activation as well as understand that the HV system may not have been shut down.



Service Disconnect Located in Trunk

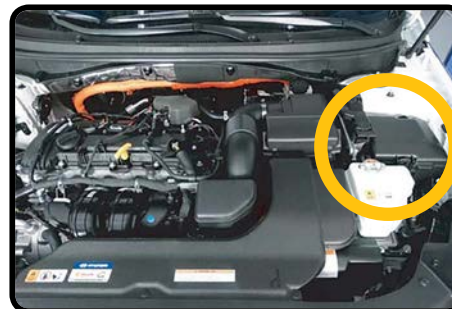

Fuse Box Location

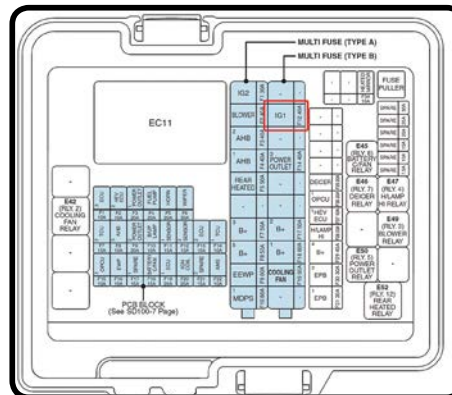

Fuse Location

WARNINGS

- NEVER cut, breach, or touch high voltage components or cabling. Doing so could result in serious injury or death.
- The high voltage system may remain powered for up to 10 minutes after the vehicle is shut off or the service disconnect plug has been removed.
- The SRS system (airbags, etc.) may remain powered for up to 3 minutes after disabling.
- Lack of engine noise does not mean vehicle is OFF. Silent movement or instant restart capability exists until vehicle is fully shut down.

HYUNDAI SONATA



2016-18

hybrid



SONATA

HYUNDAI

Li-ion (continued) **EXTRICATION INFORMATION**
See pages 15, 22.

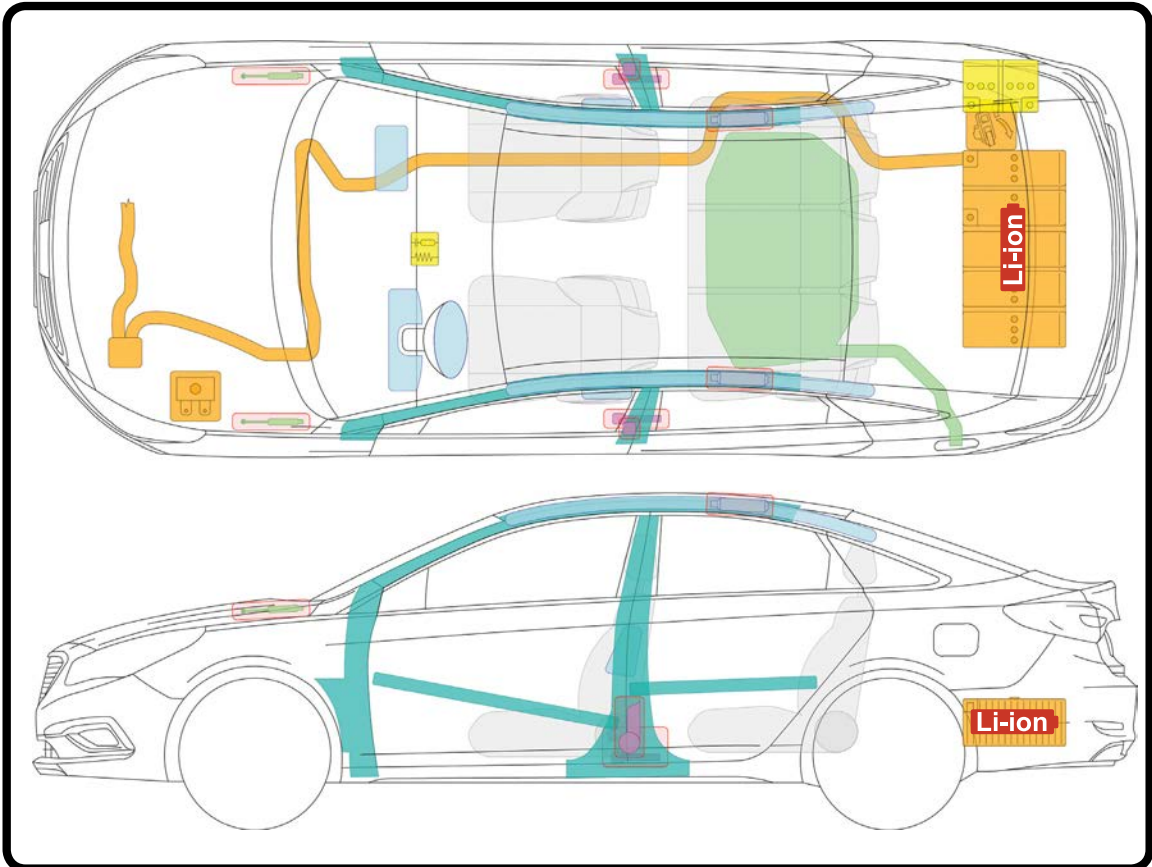

LEGEND		
Airbag	Bodywork Reinforcements	SRS Control Unit
Stored Gas Inflator	Support Cylinder for Hood	12V Battery
Seatbelt Tensioner or Pretensioner	Fuel Tank	High-Voltage Power Cable
High-Voltage Battery	Emergency Disconnect (Remove Fuse)	Emergency Disconnect (Remove Plug)

For towing and post-incident instructions, see the **POST-INCIDENT** section on page 20.



2016-18



HYUNDAI

VEHICLE INFORMATION

Li-ion

See pages 15, 22.

IMMOBILIZE VEHICLE

1. **Chock the wheels.**
2. **Set parking brake.**
(foot pedal)
3. **Place vehicle into park.**
(center console gear selector)

DISABLE VEHICLE

Determine if vehicle is ON, if the READY indicator is illuminated the vehicle is on.



PRIMARY PROCEDURE

1. If ON, turn vehicle off by pressing START/STOP button (right of steering column).
2. If possible, remove proximity key fob and keep it at least 6 feet (2 meters) from vehicle.
3. Disconnect 12V battery (passenger's side trunk).
4. Remove Service Disconnect Plug (trunk).

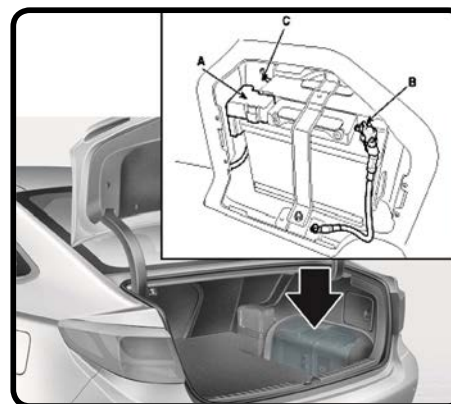

12V Battery Negative Cable in Trunk

ALTERNATE PROCEDURE

(if ignition is inaccessible)

1. Open hood and remove engine compartment fuse box cover.
2. Remove IG1 and IG2 relay. See diagram. If the correct relay cannot be identified, pull all relays and fuses in the fuse box.
3. Disconnect 12V battery (passenger's side trunk).
4. Remove Service Disconnect Plug (trunk).

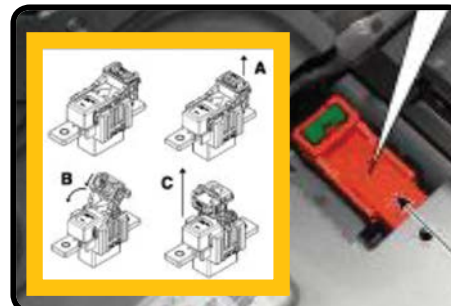

Service Disconnect Located in Trunk



Fuse Location

WARNINGS

- NEVER cut, breach, or touch high voltage components or cabling. Doing so could result in serious injury or death.
- The high voltage system may remain powered for up to 5 minutes after the vehicle is shut off or the service disconnect plug has been removed.
- The SRS system (airbags, etc.) may remain powered for up to 3 minutes after disabling.
- Lack of engine noise does not mean vehicle is OFF. Silent movement or instant restart capability exists until vehicle is fully shut down.

HYUNDAI SONATA



2016-18

hybrid



SONATA

HYUNDAI

Li-ion (continued) **EXTRICATION INFORMATION**

See pages 15, 22.

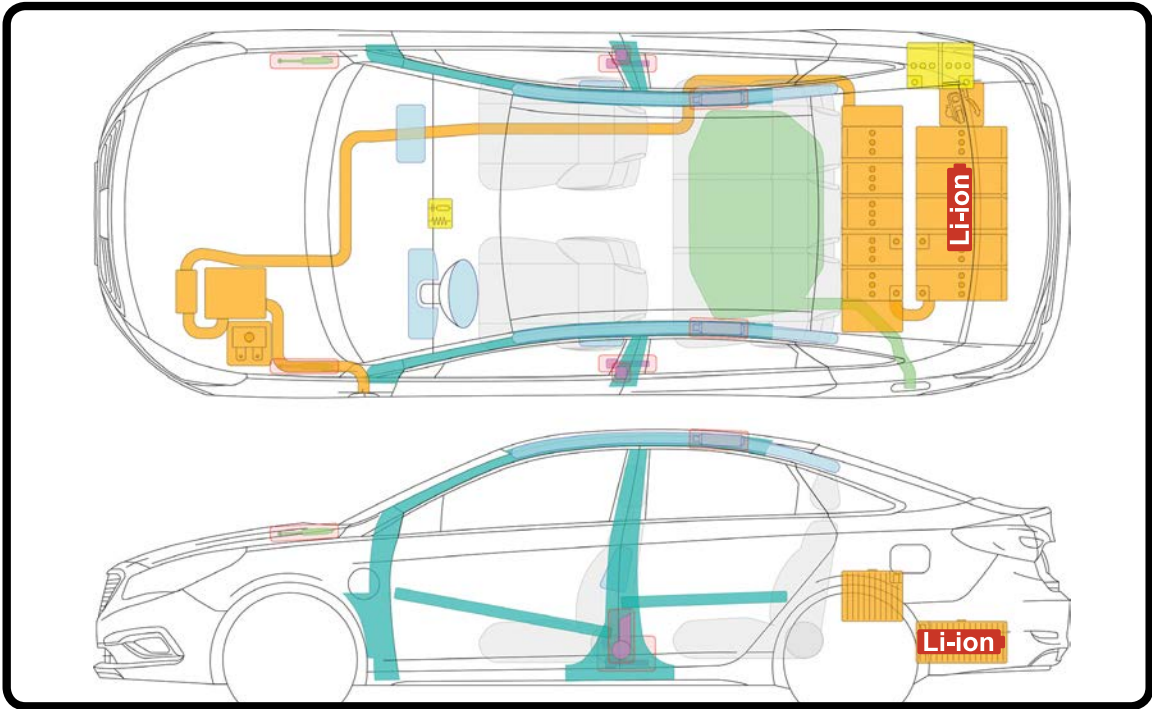

LEGEND		
Airbag	Bodywork Reinforcements	SRS Control Unit
Stored Gas Inflator	Support Cylinder for Hood	12V Battery
Seatbelt Tensioner or Pretensioner	Fuel Tank	High-Voltage Power Cable
High-Voltage Battery	Emergency Disconnect (Remove Fuse)	Emergency Disconnect (Remove Plug)

SPECIAL CONCERNS

A PLUGGED IN VEHICLE

If the vehicle is plugged in for charging, you should first unplug it. If access to unplug the vehicle is unavailable, “remove charge power” from the vehicle (done by turning off the power to the charge station).



Vehicle Charging Plug

For towing and post-incident instructions, see the **POST-INCIDENT** section on page 20.



2013-17



HYUNDAI

HYUNDAI

Tucson

VEHICLE INFORMATION

 See page 24.

IMMOBILIZE VEHICLE

1. **Chock the wheels.**
2. **Set parking brake.**
(foot pedal)
3. **Place vehicle into park.**
(center console gear selector)

DISABLE VEHICLE

Determine if vehicle is ON by presence of READY indicator or color of LED on START/STOP button: Blue (on) or Red (accessory mode).



12V Battery In Trunk

PRIMARY PROCEDURE

1. If ON, turn vehicle off by pressing START/STOP button (right of steering column). LED light should be OFF.
2. If possible, remove proximity key fob and keep it at least 6 feet (2 meters) from vehicle.
3. Disconnect 12V battery negative cable (driver's side trunk).
4. Remove Service Disconnect Plug (trunk). Lift the locking hook (A) in the direction of the arrow. Remove the safety plug after pulling the lever (B) 90 degrees in the direction of the arrow.

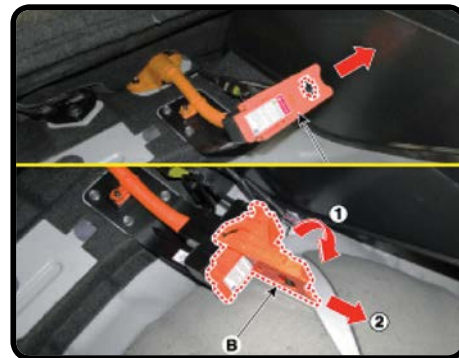

HV Disconnect

ALTERNATE PROCEDURE



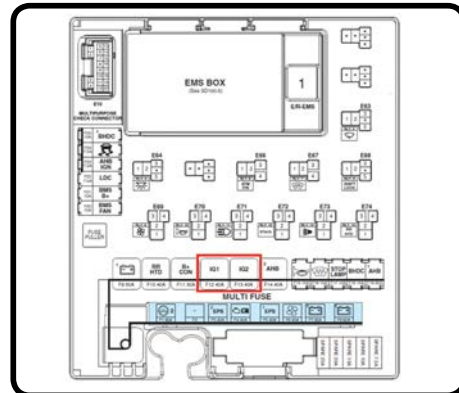

(if ignition is inaccessible)

1. Open hood and remove engine compartment fuse box cover.
2. Remove IG1, IG2 fuses. If the correct fuse cannot be identified, pull all fuses and relays from the fuse box.
3. Disconnect 12V battery negative cable (driver's side trunk).
4. Remove Service Disconnect Plug (trunk). Lift the locking hook (A) in the direction of the arrow. Remove the safety plug after pulling the lever (B) 90 degrees in the direction of the arrow.



Fuse Location

WARNINGS

-  NEVER cut, breach, or touch high voltage components or cabling. Doing so could result in serious injury or death.
-  The high voltage system may remain powered for up to 10 minutes after the vehicle is shut off or the service disconnect plug has been removed.
-  The SRS system (airbags, etc.) may remain powered for up to 3 minutes after disabling.
-  Fuel cell vehicles operate silently, lack of an engine noise does not mean the vehicle is OFF. Silent movement capability exists until vehicle is fully shut down.



2013-17

Fuel Cell



H
See page 24.

(continued) EXTRICATION INFORMATION

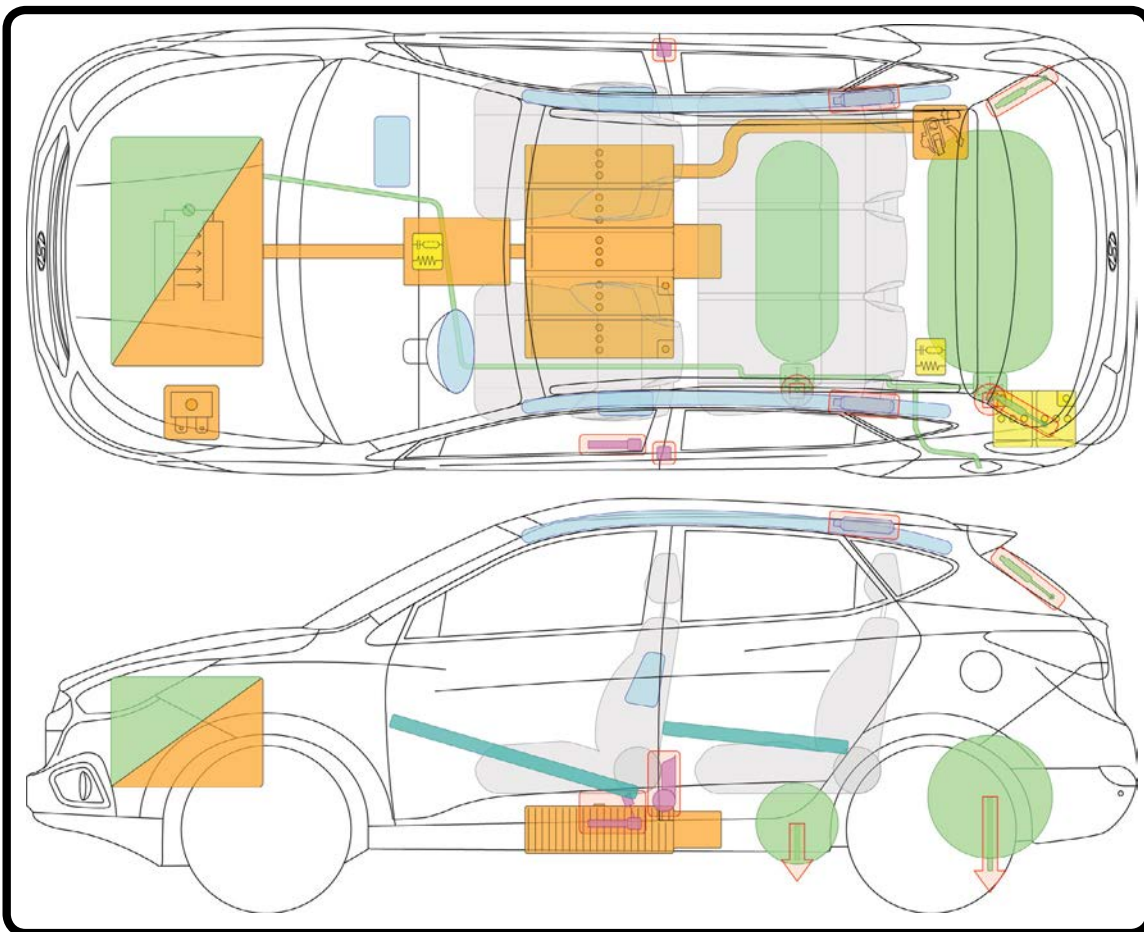

LEGEND		
Airbag	Bodywork Reinforcements	SRS Control Unit
Stored Gas Inflator	Support Cylinder for Hood	12V Battery
Seatbelt Tensioner or Pretensioner	Fuel Tank	High-Voltage Power Cable
High-Voltage Battery	Emergency Disconnect (Remove Plug)	Pressure Relief Valve

For towing and post-incident instructions, see the **POST-INCIDENT** section on page 20.



2012-13

HYBRID



INFINITI
M35h

VEHICLE INFORMATION

Li-ion

See pages 15, 22.

IMMOBILIZE VEHICLE

1. Chock wheels.
2. Set parking brake. (foot pedal)
3. Place vehicle into park. (lever, center console)

DISABLE VEHICLE

Determine if the vehicle is ON by presence of READY indicator:



PRIMARY PROCEDURE

1. If ON, push ignition switch (instrument panel, right of steering wheel).
2. Verify READY indicator is OFF.
3. If possible, remove proximity key and keep it at least 16 feet (5 meters) away from vehicle.
4. Disconnect negative 12V battery cable (trunk).

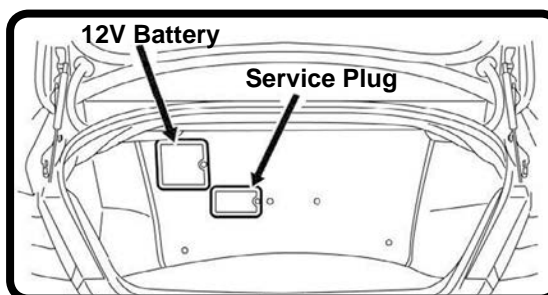

ALTERNATE PROCEDURE 1

(if ignition is inaccessible, but hood and trunk are)

1. Disconnect negative 12V battery cable (trunk).
2. Open hood, remove fuse box cover.
3. Remove fusible link.
4. If you cannot identify fusible link, remove all fuses in fuse box.

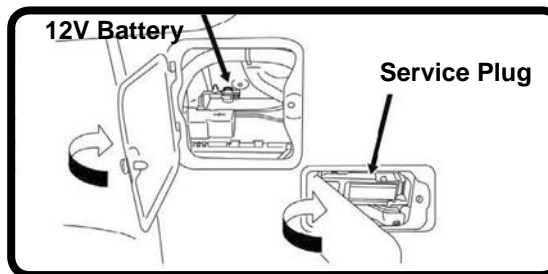

The low voltage battery is located in the trunk on the left side of the HV battery and is concealed by a trim cover.

ALTERNATE PROCEDURE 2

(if ignition not accessible, and electrical PPE is available)

1. Disconnect negative 12V battery cable (trunk).
2. Remove the service plug.

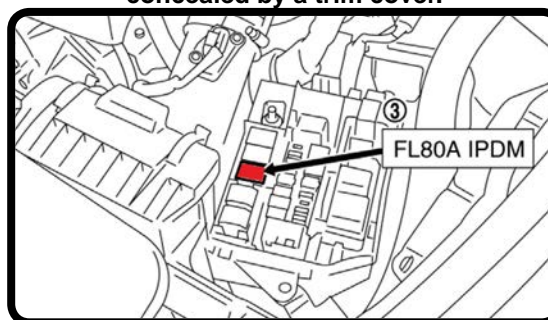

Fuse Box and Fuse Location

WARNINGS (continued on the next page)



NEVER cut, breach, or touch orange high voltage components or cabling. Doing so could result in serious injury or death.



The high voltage system and capacitor may remain powered for up to 10 minutes after the vehicle is shut off (but voltage will be below 60V after 5 minutes).



Wait 3 minutes for complete discharge of the airbag capacitor after the 12V battery cable has been disconnected.

HEV



2012-13 HYBRID



INFINITI M35h

Li-ion (continued) EXTRICATION INFORMATION

See pages 15, 22.

WARNINGS (continued)

- Removal of the service plug requires the use of electrical PPE (insulated gloves, shoes, and face shield).
- Lack of engine noise does not mean vehicle is OFF. Silent movement or instant restart capability exists until vehicle is fully shut down.

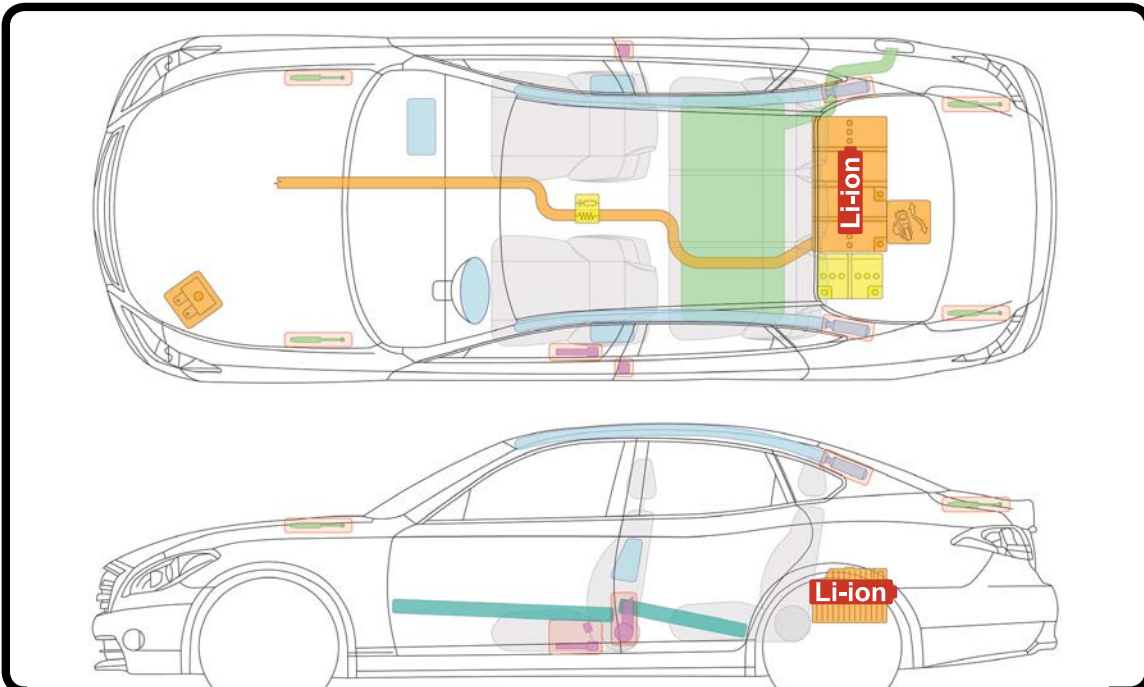

LEGEND		
Airbag	Bodywork Reinforcements	SRS Control Unit
Stored Gas Inflator	Support Cylinder for Hood	12V Battery
Seatbelt Tensioner or Pretensioner	Fuel Tank	High-Voltage Power Cable
High-Voltage Battery	Emergency Disconnect (Remove Fuse)	Emergency Disconnect (Remove Plug)

STORAGE

The service disconnect should be removed prior to vehicle storage.

For towing and post-incident instructions, see the **POST-INCIDENT** section on page 20.



2014-18

HYBRID

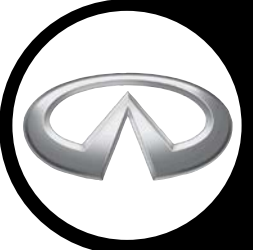

INFINITI
Q50

VEHICLE INFORMATION

Li-ion

See pages 15, 22.

IMMOBILIZE VEHICLE

- 1. **Chock wheels.**
- 2. **Set parking brake.**
(foot pedal)
- 3. **Place vehicle into park.**
(lever, center console)

DISABLE VEHICLE

Determine if the vehicle is ON by presence of READY indicator:



PRIMARY PROCEDURE

- 1. If ON, push ignition switch (instrument panel, right of steering wheel).
- 2. Verify READY indicator is OFF.
- 3. If possible, remove proximity key and keep it at least 16 feet (5 meters) away from vehicle.
- 4. Disconnect negative 12V battery cable (trunk).

NOTE: To access the trunk; (1) trunk release power cancel switch (glove box) should be ON, (2) PUSH trunk release switch (left of steering wheel).

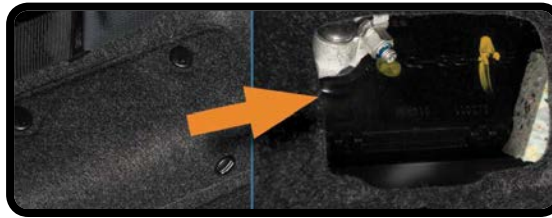

12V Negative Disconnect in Trunk

ALTERNATE PROCEDURE 1

(if ignition is inaccessible, but hood and trunk are)

- 1. Open hood, remove fuse box cover.
- 2. Disconnect fusible link (black connector).
- 3. Disconnect negative 12V battery cable (trunk).

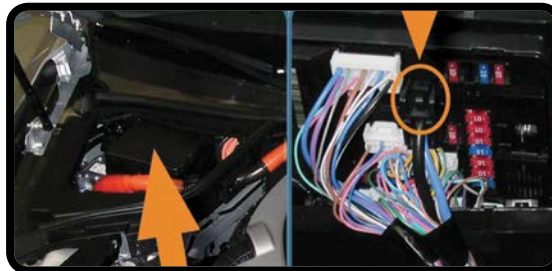

Fuse and Box in Engine Compartment

ALTERNATE PROCEDURE 2

(if ignition not accessible, and electrical PPE is available)

- 1. Disconnect negative 12V battery cable (trunk).
- 2. Remove the service plug (trunk).



Service Plug in Trunk

WARNINGS (continued on the next page)



NEVER cut, breach, or touch orange high voltage components or cabling. Doing so could result in serious injury or death.



The high voltage system and capacitor may remain powered for up to 10 minutes after the vehicle is shut off.



Wait 3 minutes for complete discharge of the airbag capacitor after the 12V battery cable has been disconnected.

HEV



2014-18 HYBRID



INFINITI Q50

Li-ion (continued) EXTRICATION INFORMATION

WARNINGS (continued)

- Removal of the service plug requires the use of electrical PPE (insulated gloves, shoes, and face shield).
- Lack of engine noise does not mean vehicle is OFF. Silent movement or instant restart capability exists until vehicle is fully shut down.

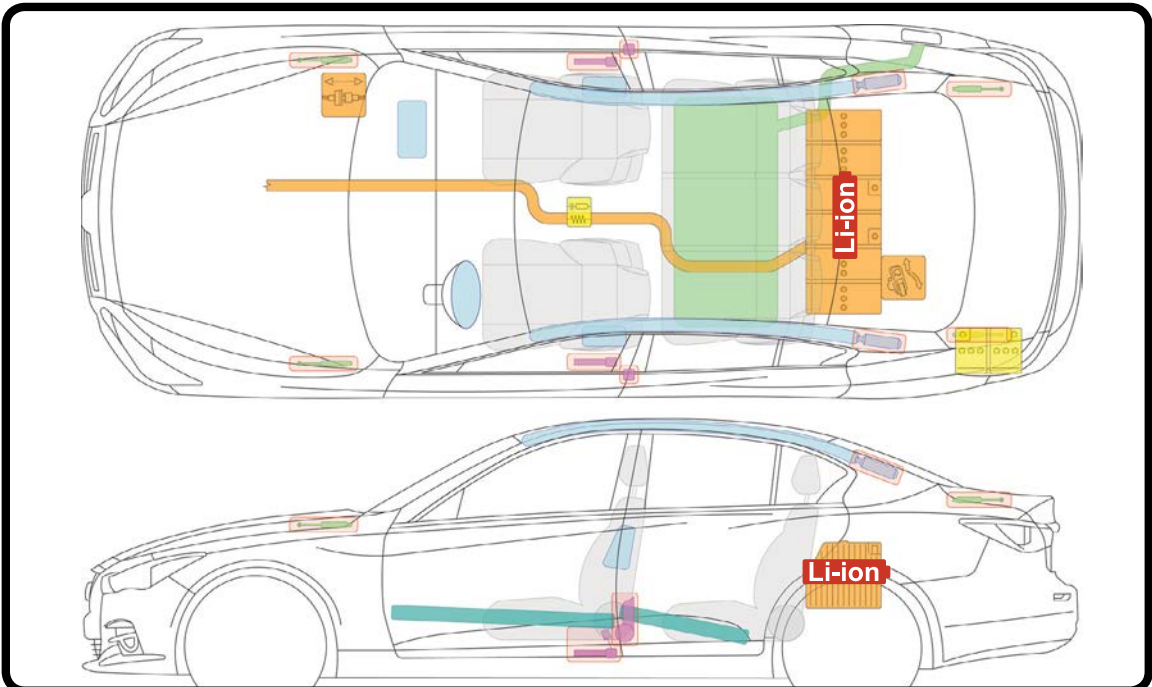

LEGEND		
Airbag	Bodywork Reinforcements	SRS Control Unit
Stored Gas Inflator	Support Cylinder for Hood	12V Battery
Seatbelt Tensioner or Pretensioner	Fuel Tank	High-Voltage Power Cable
High-Voltage Battery	Emergency Disconnect (Disconnect Plug)	Emergency Disconnect (Remove Plug)

STORAGE

The service disconnect should be removed prior to vehicle storage.

For towing and post-incident instructions, see the **POST-INCIDENT** section on page 20.



2014-18

HYBRID



INFINITI
Q70

VEHICLE INFORMATION

Li-ion

See pages 15, 22.

IMMOBILIZE VEHICLE

- | | | |
|-------------------------|--|---|
| 1. Chock wheels. | 2. Set parking brake.
(foot pedal) | 3. Place vehicle into park.
(lever, center console) |
|-------------------------|--|---|

DISABLE VEHICLE

Determine if the vehicle is ON by presence of READY indicator:



PRIMARY PROCEDURE

1. If ON, push ignition switch (instrument panel, right of steering wheel).
2. Verify READY indicator is OFF.
3. If possible, remove proximity key and keep it at least 16 feet (5 meters) away from vehicle.
4. Disconnect negative 12V battery cable (trunk).

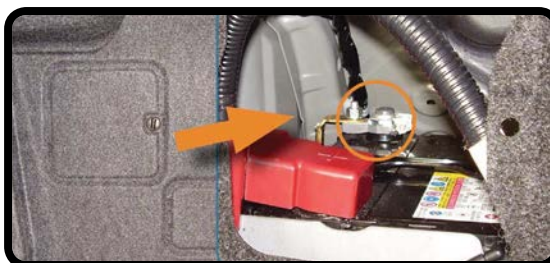

12V Negative Disconnect in Trunk

ALTERNATE PROCEDURE 1

(if ignition is inaccessible, but hood and trunk are)

1. Open hood, remove fuse box cover.
2. Disconnect fusible link (black connector).
3. Disconnect negative 12V battery cable (trunk).



Fuse and Box in Engine Compartment

ALTERNATE PROCEDURE 2

(if ignition not accessible, and electrical PPE is available)

1. Disconnect negative 12V battery cable (trunk).
2. Remove the service plug (trunk). (1) release lever, (2) rotate green lever, (3) pull out plug.

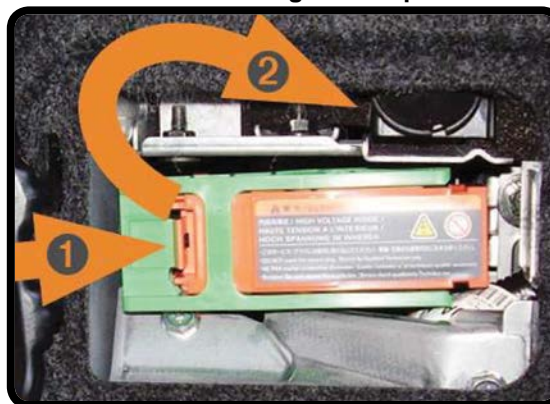

Service Plug in Trunk

WARNINGS (continued on the next page)



NEVER cut, breach, or touch orange high voltage components or cabling. Doing so could result in serious injury or death.



The high voltage system and capacitor may remain powered for up to 10 minutes after the vehicle is shut off.



Wait 3 minutes for complete discharge of the airbag capacitor after the 12V battery cable has been disconnected.

HEV



2014-18 HYBRID



INFINITI Q70

Li-ion (continued) EXTRICATION INFORMATION

See pages 15, 22.

WARNINGS (continued)

- Removal of the service plug requires the use of electrical PPE (insulated gloves, shoes, and face shield).
- Lack of engine noise does not mean vehicle is OFF. Silent movement or instant restart capability exists until vehicle is fully shut down.

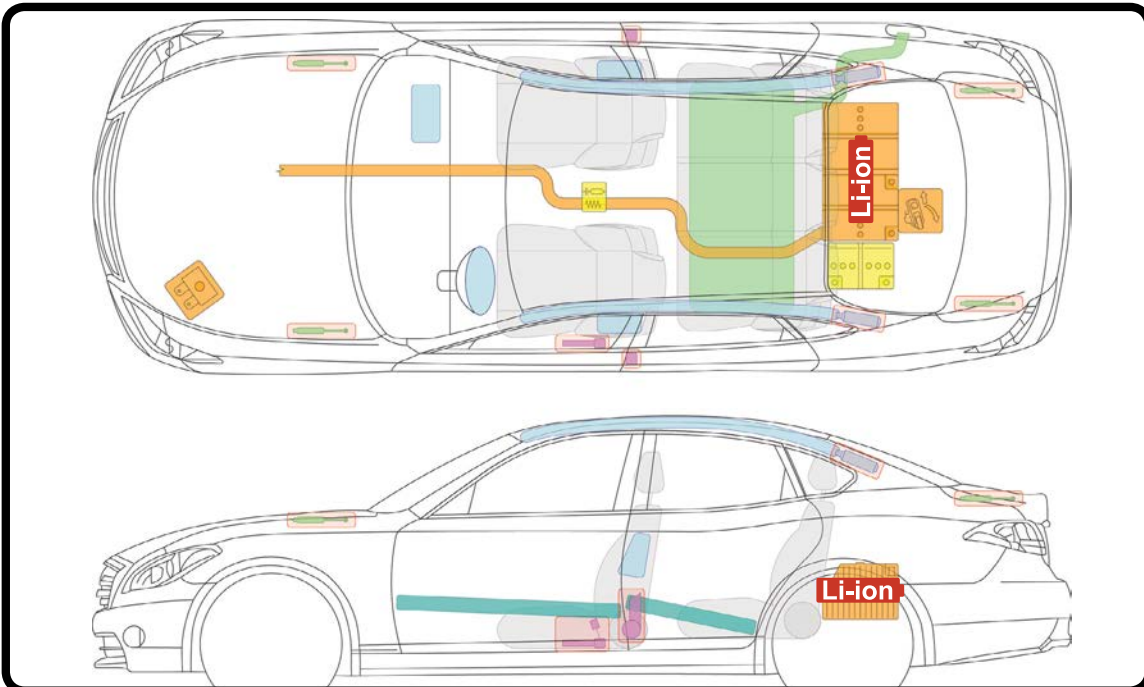

LEGEND		
	Airbag	
	Stored Gas Inflator	
	Seatbelt Tensioner or Pretensioner	
	High-Voltage Battery	
	Bodywork Reinforcements	
	Support Cylinder for Hood	
	Fuel Tank	

STORAGE

The service disconnect should be removed prior to vehicle storage.

For towing and post-incident instructions, see the **POST-INCIDENT** section on page 20.



2014-17

HYBRID

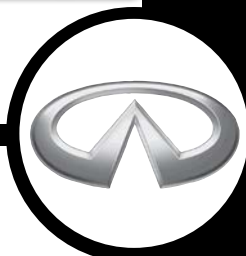

VEHICLE INFORMATION

Li-ion

See pages 15, 22.

IMMOBILIZE VEHICLE

- 1. Chock wheels.
- 2. Set parking brake. (foot pedal)
- 3. Place vehicle into park. (lever, center console)

DISABLE VEHICLE

Determine if the vehicle is ON by presence of READY indicator:



PRIMARY PROCEDURE

- 1. If ON, push ignition switch (instrument panel, right of steering wheel).
- 2. Verify READY indicator is OFF.
- 3. If possible, remove proximity key and keep it at least 16 feet (5 meters) away from vehicle.
- 4. Disconnect negative 12V battery cable (under hood).



12V Negative Disconnect Under Hood

ALTERNATE PROCEDURE 1

(if ignition is inaccessible, but hood and trunk are)

- 1. Open under-hood fuse box.
- 2. Remove fuse F/L V IGCT RLY 50A (red). If correct fuse cannot be identified, pull all fuses in fuse box.
- 3. Disconnect negative 12V battery cable (under hood).

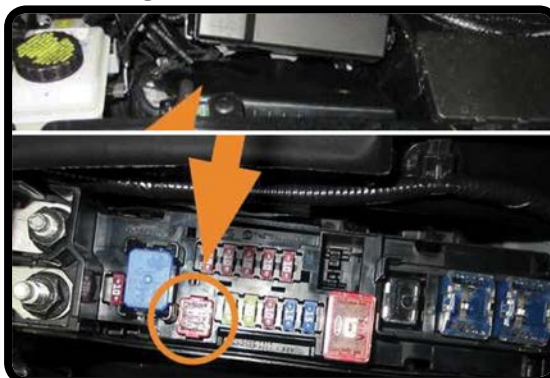

Fuse and Box in Engine Compartment

ALTERNATE PROCEDURE 2

(if ignition not accessible, and electrical PPE is available)

- 1. Disconnect negative 12V battery cable (under hood).
- 2. Remove the service plug (trunk). (1) pull lever, (2) release locking tab, (3) rotate green lever, (4) pull out plug.



Service Plug in Trunk

WARNINGS (continued on the next page)



NEVER cut, breach, or touch orange high voltage components or cabling. Doing so could result in serious injury or death.



The high voltage system and capacitor may remain powered for up to 10 minutes after the vehicle is shut off.



Wait 3 minutes for complete discharge of the airbag capacitor after the 12V battery cable has been disconnected.

INFINITI
QX60

HEV



2014-17 HYBRID



INFINITI QX60

Li-ion (continued) EXTRICATION INFORMATION

See pages 15, 22.

WARNINGS (continued)

- Removal of the service plug requires the use of electrical PPE (insulated gloves, shoes, and face shield).
- Lack of engine noise does not mean vehicle is OFF. Silent movement or instant restart capability exists until vehicle is fully shut down.

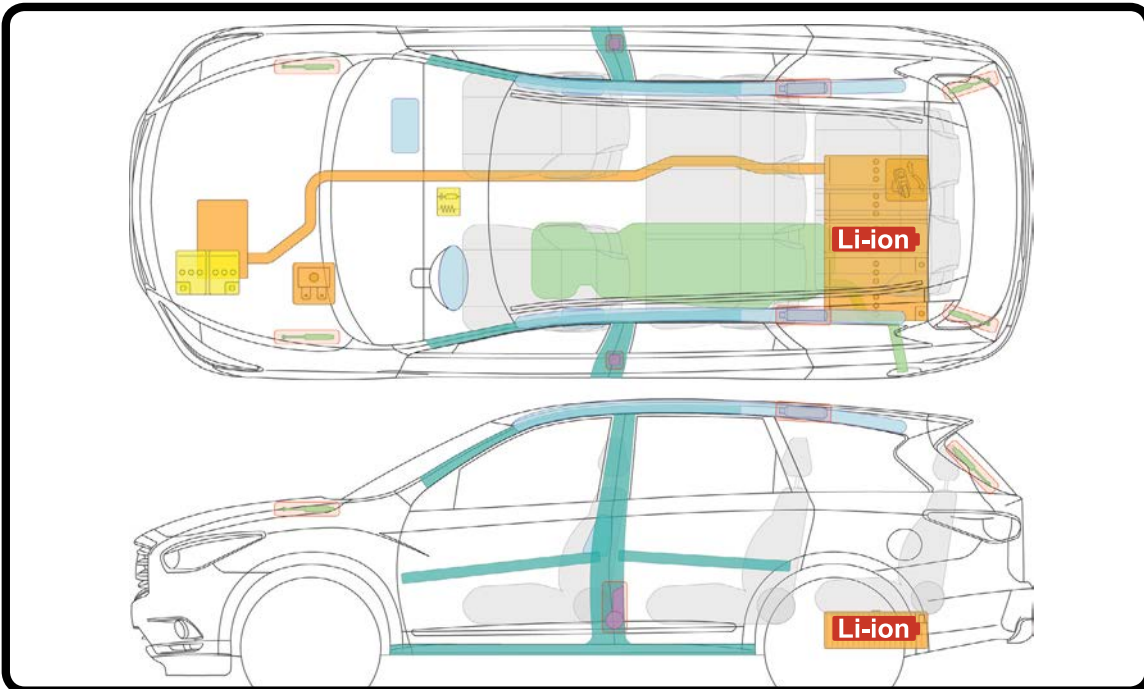

LEGEND		
Airbag	Bodywork Reinforcements	SRS Control Unit
Stored Gas Inflator	Support Cylinder for Hood	12V Battery
Seatbelt Tensioner or Pretensioner	Fuel Tank	High-Voltage Power Cable
High-Voltage Battery	Emergency Disconnect (Remove Fuse)	Emergency Disconnect (Remove Plug)

STORAGE

The service disconnect should be removed prior to vehicle storage.

For towing and post-incident instructions, see the **POST-INCIDENT** section on page 20.



2017-18



KIA

KIA

NIRO

VEHICLE INFORMATION

Li-ion
See pages 15, 22.

IMMOBILIZE VEHICLE

1. Chock wheels.
2. Set parking brake. (foot pedal)
3. Place vehicle into park. (center console gear selector)

DISABLE VEHICLE

Determine if the vehicle is ON by presence of READY indicator.



PRIMARY PROCEDURE

1. If ON, turn vehicle off (START/STOP button right of steering column).
2. If possible, remove proximity key and keep it at least 6 feet (2 meters) from vehicle.
3. Disconnect 12V battery negative cable connector (trunk, driver's side).
4. Remove safety plug cover (under rear seat, near floorboard of passenger's side). Then unfasten the hook and pull lever to remove the safety plug.

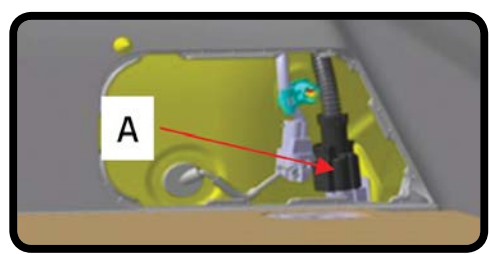

High Voltage Battery Negative Connector



Safety Plug Under Rear Seat

ALTERNATE PROCEDURE 1

(if ignition is inaccessible)

1. Disconnect 12V battery negative cable connector (trunk, driver's side).
2. Open hood and remove engine compartment fuse box cover.
3. Remove IG1 and IG2 fuses (see diagram). If the correct fuse cannot be identified, pull all fuses in the fuse box.
4. Remove safety plug cover (under rear seat, near floorboard of passenger's side). Then unfasten the hook and pull lever to remove the safety plug.

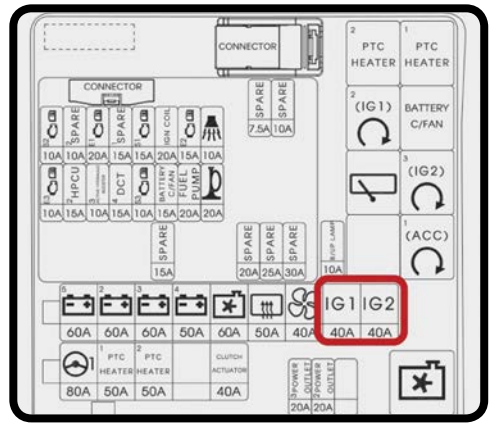

Fuse Location

WARNINGS

- NEVER cut, breach, or touch high voltage components or cabling. Doing so could result in serious injury or death.
- The high voltage system may remain powered for up to 5 minutes after the vehicle is shut off.
- The SRS system (airbags, etc.) may remain powered for up to 3 minutes after disabling.
- Lack of engine noise does not mean vehicle is OFF. Silent movement or instant restart capability exists until vehicle is fully shut down.

HEV



2017-18

ECO hybrid







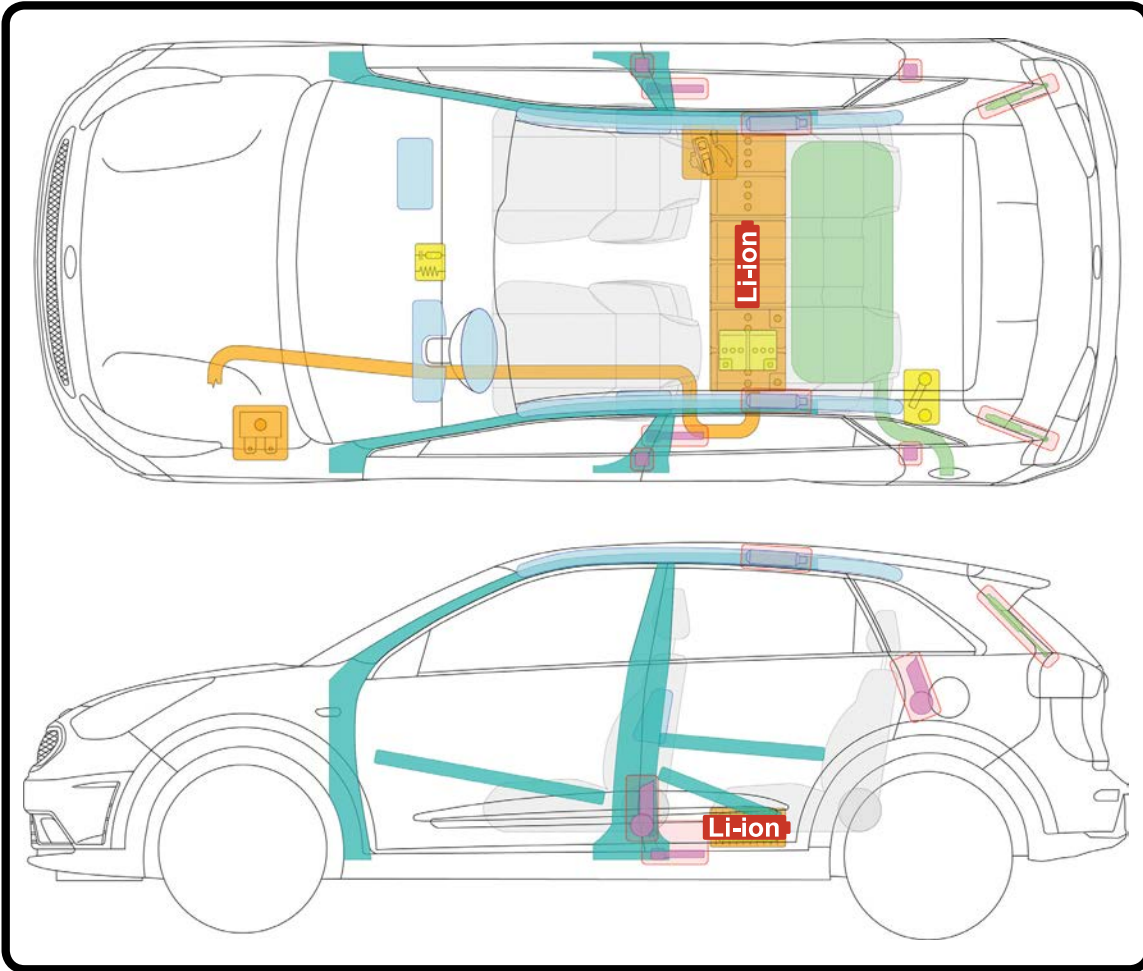





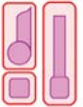

Li-ion (continued) **EXTRICATION INFORMATION**

See pages 15, 22.



LEGEND

 Airbag	 Bodywork Reinforcements	 SRS Control Unit
 Stored Gas Inflator	 Support Cylinder for Hood	 12V Battery
 Seatbelt Tensioner or Pretensioner	 Fuel Tank	 High-Voltage Power Cable
 High-Voltage Battery	 Emergency Disconnect (Remove Fuse)	 Emergency Disconnect (Remove Plug)

For towing and post-incident instructions, see the **POST-INCIDENT** section on page 20.

KIA NIRO



2018



KIA

KIA

NIRO

VEHICLE INFORMATION

Li-ion

See pages 15, 22.

IMMOBILIZE VEHICLE

1. Chock wheels.
2. Set parking brake. (foot pedal)
3. Place vehicle into park. (center console gear selector)

DISABLE VEHICLE

Determine if the vehicle is ON by presence of READY indicator.



PRIMARY PROCEDURE

1. If ON, turn vehicle off (START/STOP button right of steering column).
2. If possible, remove proximity key and keep it at least 6 feet (2 meters) from vehicle.
3. Disconnect 12V battery negative cable (trunk, right side).
4. Disconnect high voltage safety plug (trunk, under luggage board and cover).



12V Battery Negative Cable

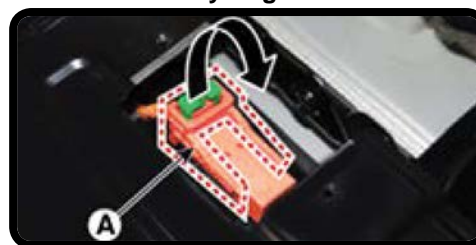

Safety Plug In Trunk Under Cover

ALTERNATE PROCEDURE 1

(if ignition is inaccessible)

1. Disconnect 12V battery negative cable (trunk, right side).
2. Open hood and remove engine compartment fuse box cover.
3. Remove IG1 and IG2 fuses (see diagram). If the correct fuse cannot be identified, pull all fuses in the fuse box.
4. Disconnect high voltage safety plug (trunk, under luggage board and cover).

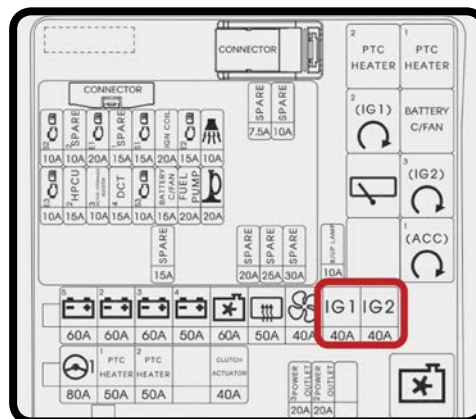

Fuse Location

WARNINGS

- NEVER cut, breach, or touch high voltage components or cabling. Doing so could result in serious injury or death.
- The high voltage system may remain powered for up to 5 minutes after the vehicle is shut off.
- The SRS system (airbags, etc.) may remain powered for up to 3 minutes after disabling.
- Lack of engine noise does not mean vehicle is OFF. Silent movement or instant restart capability exists until vehicle is fully shut down.



2018

ECO plug-in



Li-ion

(continued)

EXTRICATION INFORMATION

See pages 15, 22.

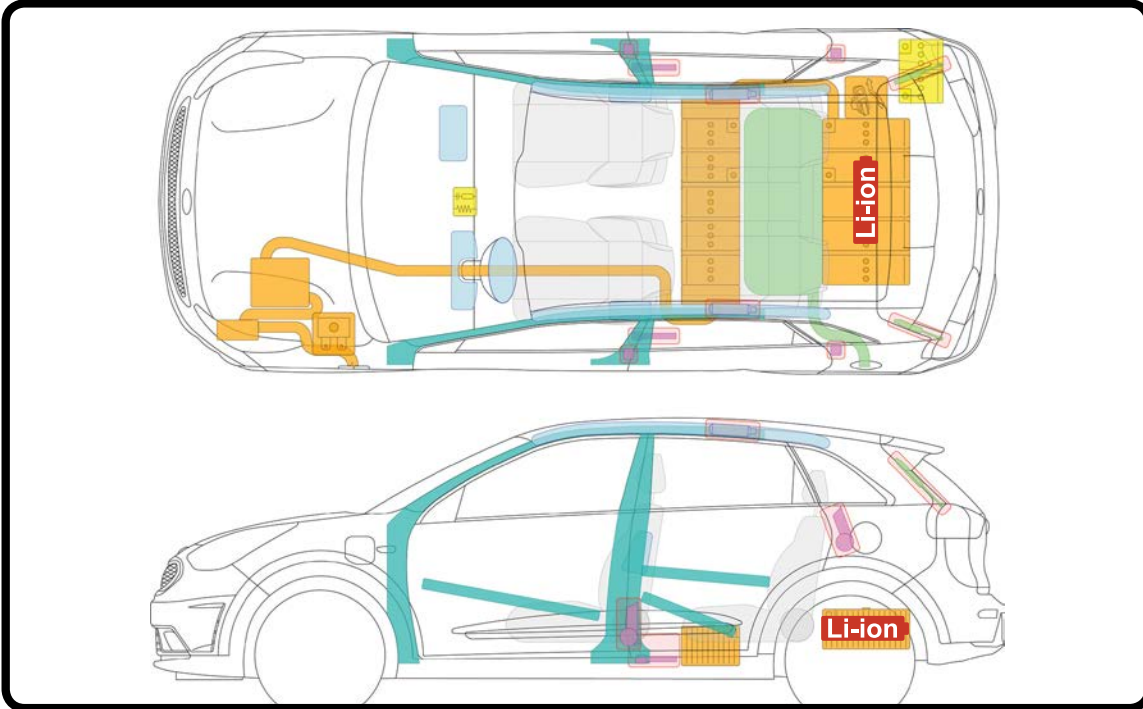

LEGEND

Airbag	Bodywork Reinforcements	SRS Control Unit
Stored Gas Inflator	Support Cylinder for Hood	12V Battery
Seatbelt Tensioner or Pretensioner	Fuel Tank	High-Voltage Power Cable
High-Voltage Battery	Emergency Disconnect (Remove Fuse)	Emergency Disconnect (Remove Plug)

SPECIAL CONCERNS

A PLUGGED IN VEHICLE

If the vehicle is plugged in for charging, you should first unplug it. If access to unplug the vehicle is unavailable, “remove charge power” from the vehicle (done by turning off the power to the charge station).



Vehicle Charging Plug

For towing and post-incident instructions, see the **POST-INCIDENT** section on page 20.



2011-16



KIA

KIA

OPTIMA

VEHICLE INFORMATION

IMMOBILIZE VEHICLE

1. Chock wheels.
2. Set parking brake. (foot pedal)
3. Place vehicle into park. (center console gear selector)

DISABLE VEHICLE

Determine if the vehicle is ON by presence of READY indicator.

PRIMARY PROCEDURE

1. If ON, turn vehicle off (START/STOP button right of steering column).
2. If possible, remove proximity key and keep it at least 6 feet (2 meters) from vehicle.
3. Disconnect 12V battery negative cable (trunk, right side).

NOTE: If unable to open trunk due to dead battery, use the Emergency Trunk Lid Release Cable located behind driver's side rear headrest.

ALTERNATE PROCEDURE 1

(if ignition is inaccessible)

1. Disconnect 12V battery negative cable (trunk, right side).
2. Open hood and remove engine compartment fuse box cover.
3. Remove PDM2 relay (see diagram). If the correct relay cannot be identified, pull all fuses in the fuse box.

ALTERNATE PROCEDURE 2

(if ignition and PDM2 Relay are inaccessible)

1. Disconnect 12V battery negative cable (trunk, right side).
2. Remove Safety Plug Access Cover.
3. Remove Safety Plug (lift locking hook up, pull down lever, remove plug). (See next page for diagram.)

WARNINGS (continued on the next page)



NEVER cut, breach, or touch high voltage components or cabling. Doing so could result in serious injury or death.



The high voltage system may remain powered for up to 5 minutes after the vehicle is shut off.



Emergency Trunk Lid Release

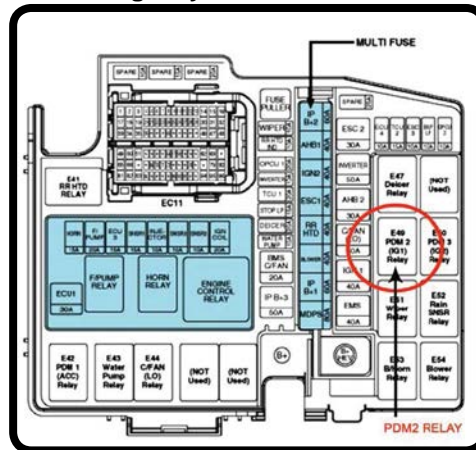

Fuse Location



12V Battery and Service Plug in Trunk

NOTE: In order to remove the HEV Safety Plug, you must wear insulated electrical PPE (safety glasses and gloves rated for at least 1000V).



2011-16

HYBRID



(continued) **EXTRICATION INFORMATION**

WARNINGS (continued)

- The SRS system (airbags, etc.) may remain powered for up to 3 minutes after disabling.
- Wear PPE including safety glasses and insulating gloves rated for 1,000V and above when handling high voltage components.
- Lack of engine noise does not mean vehicle is OFF. Silent movement or instant restart capability exists until vehicle is fully shut down.

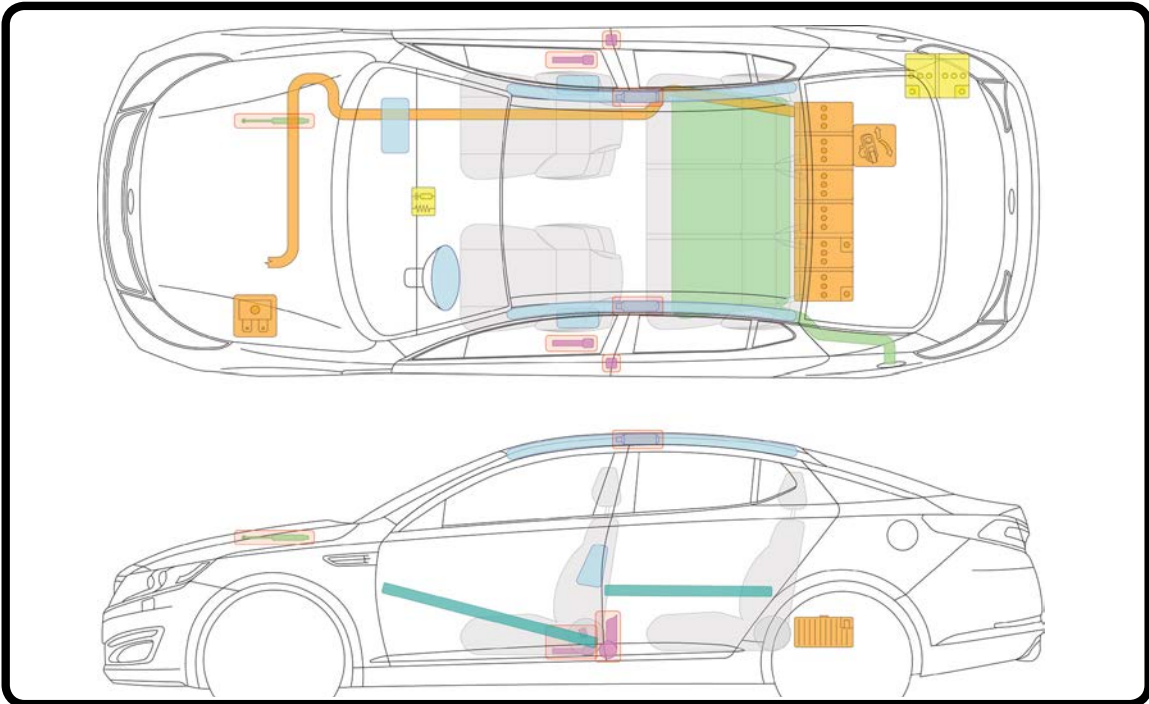

LEGEND

Airbag	Bodywork Reinforcements	SRS Control Unit
Stored Gas Inflator	Support Cylinder for Hood	12V Battery
Seatbelt Tensioner or Pretensioner	Fuel Tank	High-Voltage Power Cable
High-Voltage Battery	Emergency Disconnect (Remove Fuse)	Emergency Disconnect (Remove Plug)

For towing and post-incident instructions, see the **POST-INCIDENT** section on page 20.



2017-18

eco hybrid



KIA

KIA

OPTIMA

VEHICLE INFORMATION

Li-ion

See pages 15, 22.

IMMOBILIZE VEHICLE

1. **Chock wheels.**
2. **Set parking brake.**
(electric switch, center console)
3. **Place vehicle into park.**
(center console gear selector)

DISABLE VEHICLE

Determine if the vehicle is ON by presence of READY indicator.



PRIMARY PROCEDURE

1. If ON, turn vehicle off (POWER button, center console).
2. If possible, remove proximity key and keep it at least 6 feet (2 meters) from vehicle.
3. Disconnect 12V battery negative cable (trunk, right side).
4. Disconnect high voltage safety plug (trunk, under luggage board and cover).



12V Battery Negative Cable in Trunk

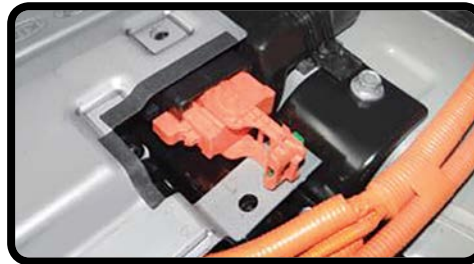

High Voltage Safety Plug in Trunk

ALTERNATE PROCEDURE 1

(if ignition is inaccessible)

1. Disconnect 12V battery negative cable (trunk, right side).
2. Open hood and remove engine compartment fuse box cover (driver's side).
3. Remove IG1 and IG2 relays (see diagram). If the correct relays cannot be identified, pull all the fuses.
4. Disconnect high voltage safety plug (trunk, under luggage board and cover).

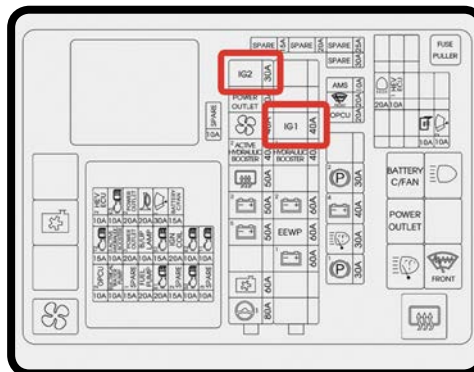

Fuse Location

WARNINGS

- NEVER cut, breach, or touch high voltage components or cabling. Doing so could result in serious injury or death.
- The high voltage system may remain powered for up to 5 minutes after the vehicle is shut off.
- The SRS system (airbags, etc.) may remain powered for up to 3 minutes after disabling.
- Lack of engine noise does not mean vehicle is OFF. Silent movement or instant restart capability exists until vehicle is fully shut down.

HEV



2017-18

ECO hybrid







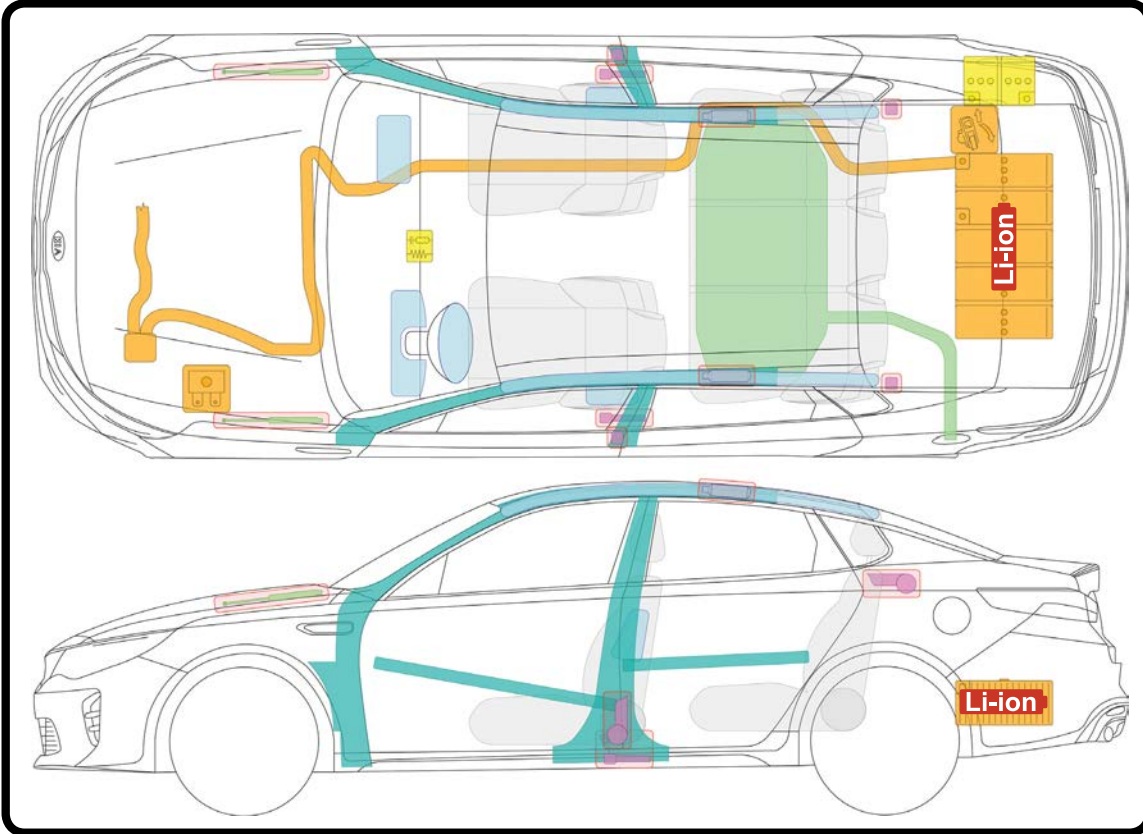



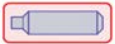

Li-ion (continued) **EXTRICATION INFORMATION**

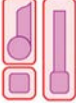
See pages 15, 22.



LEGEND

 Airbag	 Bodywork Reinforcements	 SRS Control Unit
 Stored Gas Inflator	 Support Cylinder for Hood	 12V Battery
 Seatbelt Tensioner or Pretensioner	 Fuel Tank	 High-Voltage Power Cable
 High-Voltage Battery	 Emergency Disconnect (Remove Fuse)	 Emergency Disconnect (Remove Plug)

For towing and post-incident instructions, see the **POST-INCIDENT** section on page 20.

KIA OPTIMA

KIA



2017-18

ECO plug-in



VEHICLE INFORMATION

Li-ion

See pages 15, 22.

IMMOBILIZE VEHICLE

1. Chock wheels.
2. Set parking brake. (electric switch, center console)
3. Place vehicle into park. (center console gear selector)

DISABLE VEHICLE

Determine if the vehicle is ON by presence of READY indicator.



PRIMARY PROCEDURE

1. If ON, turn vehicle off (POWER button, center console).
2. If possible, remove proximity key and keep it at least 6 feet (2 meters) from vehicle.
3. Disconnect 12V battery negative cable (trunk, right side).
4. Disconnect high voltage safety plug (trunk, under luggage board and cover).



12V Battery Negative Cable in Trunk

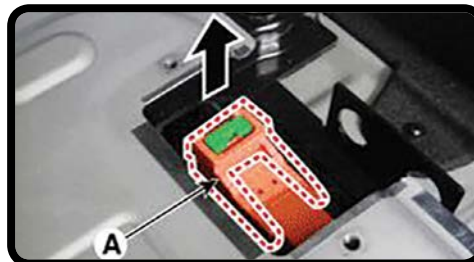

High Voltage Safety Plug in Trunk

ALTERNATE PROCEDURE 1

(if ignition is inaccessible)

1. Disconnect 12V battery negative cable (trunk, right side).
2. Open hood and remove engine compartment fuse box cover (driver's side).
3. Remove Multi Fuse A and B and IG3 relays (see diagram). If the correct relays cannot be identified, pull all the fuses.
4. Disconnect high voltage safety plug (trunk, under luggage board and cover).

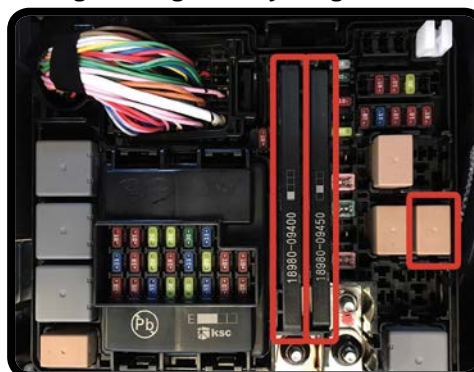

Multi Fuse A and B and IG3 Location

WARNINGS

- NEVER cut, breach, or touch high voltage components or cabling. Doing so could result in serious injury or death.
- The high voltage system may remain powered for up to 5 minutes after the vehicle is shut off.
- The SRS system (airbags, etc.) may remain powered for up to 3 minutes after disabling.
- Lack of engine noise does not mean vehicle is OFF. Silent movement or instant restart capability exists until vehicle is fully shut down.

KIA

KIA

OPTIMA



2017-18









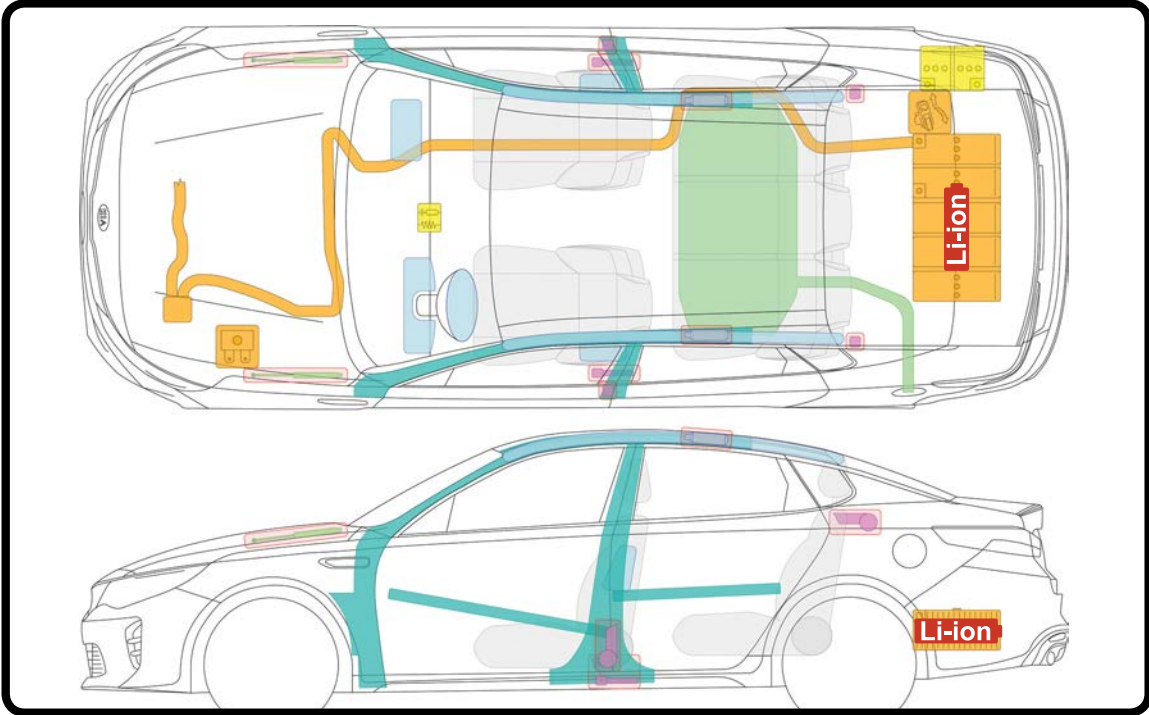

ECO plug-in

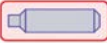

Li-ion (continued) **EXTRICATION INFORMATION**

See pages 15, 22.



LEGEND		
 Airbag	 Bodywork Reinforcements	 SRS Control Unit
 Stored Gas Inflator	 Support Cylinder for Hood	 12V Battery
 Seatbelt Tensioner or Pretensioner	 Fuel Tank	 High-Voltage Power Cable
 High-Voltage Battery	 Emergency Disconnect (Remove Fuse)	 Emergency Disconnect (Remove Plug)

SPECIAL CONCERNS

A PLUGGED IN VEHICLE

If the vehicle is plugged in for charging, you should first unplug it. If access to unplug the vehicle is unavailable, “remove charge power” from the vehicle (done by turning off the power to the charge station).



Vehicle Charging Plug

For towing and post-incident instructions, see the **POST-INCIDENT** section on page 20.



2015-18



VEHICLE INFORMATION

Li-ion
See pages 15, 22.

IMMOBILIZE VEHICLE

1. Chock wheels.
2. Set parking brake.
(electric switch, center console)
3. Place vehicle into park.
(center console gear selector)

DISABLE VEHICLE

Determine if the vehicle is ON by presence of READY indicator. 

PRIMARY PROCEDURE

1. If ON, turn vehicle off (POWER button, center console).
2. If possible, remove proximity key and keep it at least 6 feet (2 meters) from vehicle.
3. Disconnect 12V battery negative cable (engine compartment, driver's side).



Fuse Box and Battery Location

ALTERNATE PROCEDURE 1 (if ignition is inaccessible)

1. Disconnect 12V battery negative cable (engine compartment, driver's side).
2. Open hood and remove engine compartment fuse box cover (driver's side).
3. Remove IG1, IG2, IG3 relays (see diagram). If the correct relays cannot be identified, pull all the fuses.

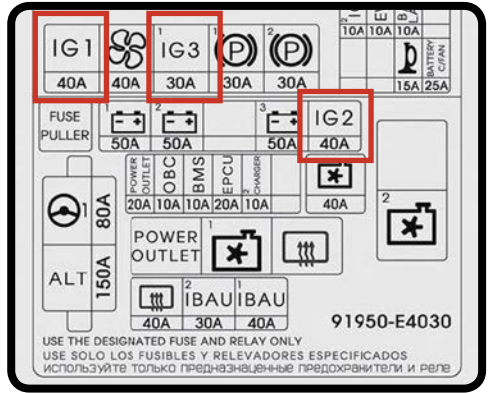

Remove IG1, IG2 and IG3 Relays

ALTERNATE PROCEDURE 2 (if ignition and relays are inaccessible)

1. Disconnect 12V battery negative cable (engine compartment, driver's side).
2. Remove Safety Plug cover (center of rear carpet, remove 10mm nuts).
3. Remove Safety Plug (slide locking hook, pull up lever, remove plug).

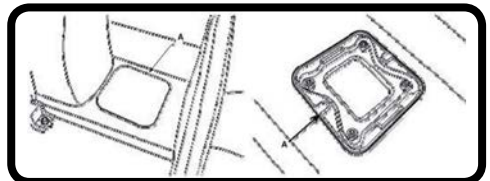





Safety Plug Cover, Remove 10mm Nuts



1. Unlock, 2. Release, 3. Remove

WARNINGS (continued on the next page)

-  NEVER cut, breach, or touch high voltage components or cabling. Doing so could result in serious injury or death.
-  The high voltage system may remain powered for up to 5 minutes after the vehicle is shut off.
-  The SRS system (airbags, etc.) may remain powered for up to 3 minutes after disabling.
-  Wear PPE including safety glasses rated for 1,000V and above when handling high voltage components.

KIA

KIA

Soul EV



2015-18

ECO electric



Li-ion (continued) **EXTRICATION INFORMATION**

See pages 15, 22.

WARNINGS (continued)



This vehicle does not have an internal combustion engine. Lack of engine noise does not mean vehicle is OFF. Silent movement capability exists until vehicle is fully shut down.

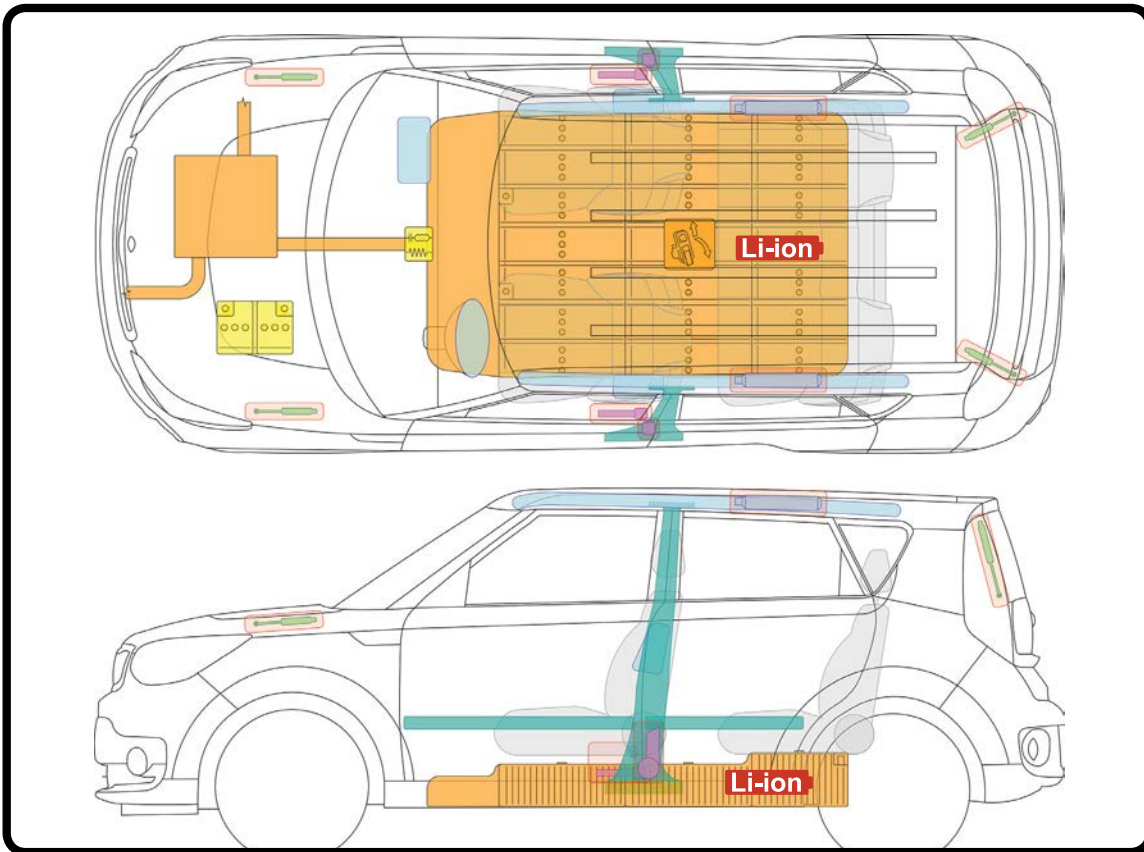

LEGEND

Airbag	Bodywork Reinforcements	SRS Control Unit
Stored Gas Inflator	Support Cylinder for Hood	12V Battery
Seatbelt Tensioner or Pretensioner	Fuel Tank	High-Voltage Power Cable
High-Voltage Battery	Emergency Disconnect (Remove Fuse)	Emergency Disconnect (Remove Plug)

For towing and post-incident instructions, see the **POST-INCIDENT** section on page 20.



2011-13



HYBRID

VEHICLE INFORMATION

IMMOBILIZE VEHICLE

- 1. **Chock the wheels.**
- 2. **Set parking brake.**
(foot pedal)
- 3. **Place vehicle into park.**
(push-button below gear selector)

DISABLE VEHICLE

Determine if vehicle is ON by illumination of READY indicator.

PRIMARY PROCEDURE

- 1. If ON, shut off ignition (push-button, right of instrument panel). Remove proximity key and keep it at least 16 feet (5 meters) from vehicle.
- 2. Disconnect 12V battery (cargo area right side, auxiliary box).

ALTERNATE PROCEDURE

(if power button is inaccessible)

- 1. Open hood and remove engine compartment fuse box cover (driver's side).
- 2. Remove IGCT fuse (30A green) and AM2 fuse (7.5A brown) from the fuse box. If the correct fuse cannot be identified, pull all fuses in fuse box.
- 3. Disconnect 12V battery (cargo area right side, auxiliary box).

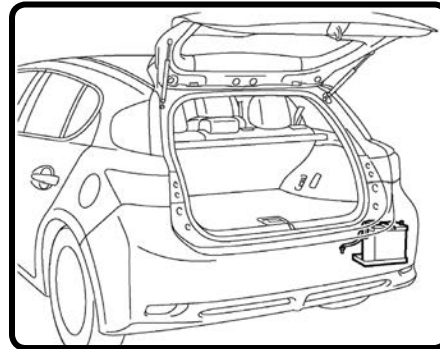



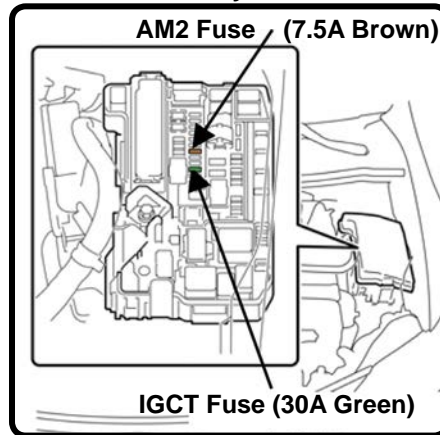

12V Battery in Trunk



IGCT and AM2 Fuse Located in the Engine Compartment

WARNINGS

-  NEVER cut, breach, or touch high voltage components or cabling. Doing so could result in serious injury or death.
-  The high voltage system may remain powered for up to 10 minutes after the vehicle is shut off.
-  The SRS System (airbags, etc.) may remain powered for up to 90 seconds after disabling.
-  There is a 27V AC Electric Power Steering (EPS) system behind the instrument cluster and routed a short distance along the steering column. 27V AC has a higher arc potential than 12V DC.
-  Lack of engine noise does not mean vehicle is OFF. Silent movement or instant restart capability exists until vehicle is fully shut down.

LEXUS

LEXUS

CT200h

HEV



2011-13

HYBRID



CT200h

(continued) **EXTRICATION INFORMATION**

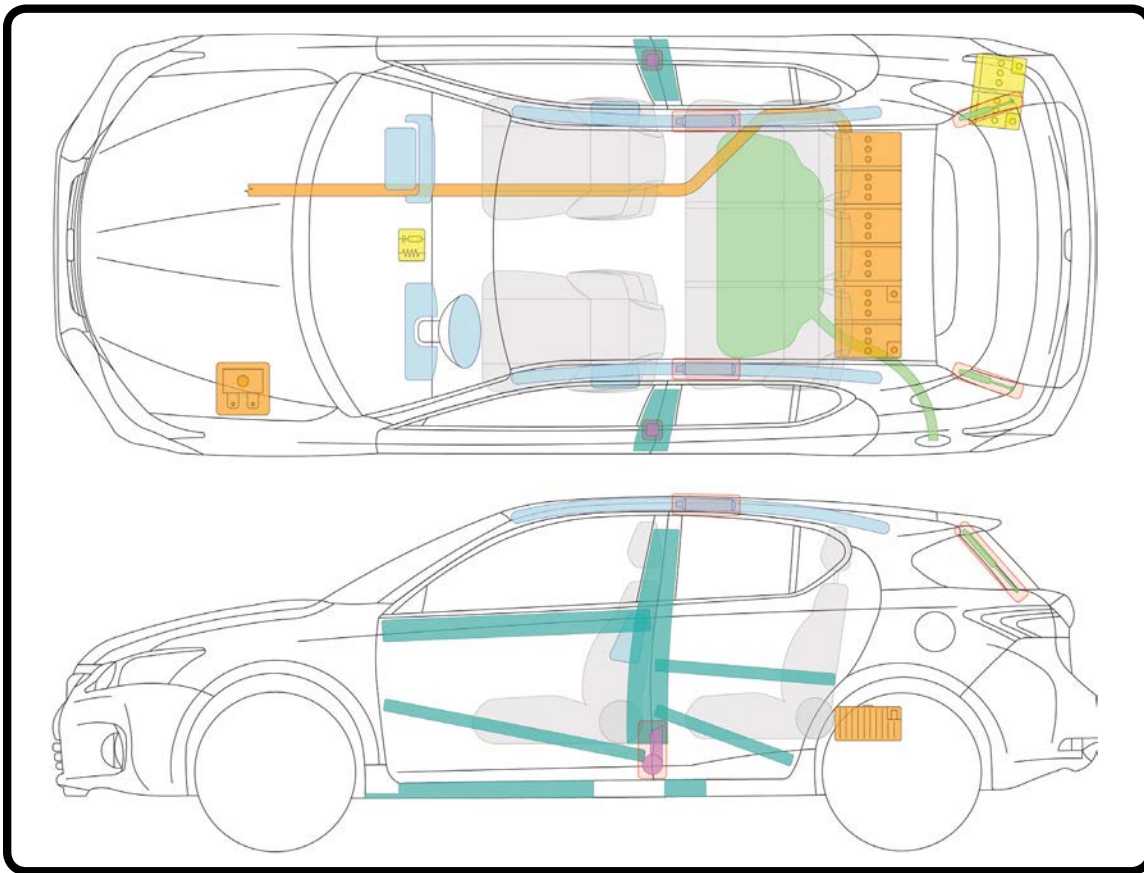

LEGEND

Airbag	Bodywork Reinforcements	SRS Control Unit
Stored Gas Inflator	Support Cylinder for Hood	12V Battery
Seatbelt Tensioner or Pretensioner	Fuel Tank	High-Voltage Power Cable
High-Voltage Battery	Emergency Disconnect (Remove Fuse)	

For towing and post-incident instructions, see the **POST-INCIDENT** section on page 20.

LEXUS

LEXUS



2014-17



HYBRID

VEHICLE INFORMATION

IMMOBILIZE VEHICLE

1. **Chock the wheels.**
2. **Set parking brake.**
(foot pedal)
3. **Place vehicle into park.**
(push-button below gear selector, center console)

DISABLE VEHICLE

Determine if vehicle is ON by illumination of READY light.

PRIMARY PROCEDURE

1. If ON, shut off ignition (push-button, right of instrument panel).
2. Remove proximity key and keep it at least 16 feet (5 meters) from vehicle.
3. Disconnect negative 12V battery cable (under luggage compartment, right side).

ALTERNATE PROCEDURE

(if power button is inaccessible)

1. Open hood and remove engine compartment fuse box cover (driver's side).
2. Remove IG2 fuse (20A yellow) from the fuse box. If the correct fuse cannot be identified, pull all fuses in fuse box.
3. Disconnect negative 12V battery cable (under luggage compartment, right side).

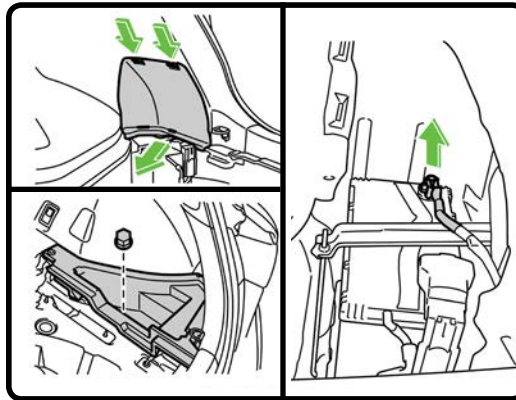



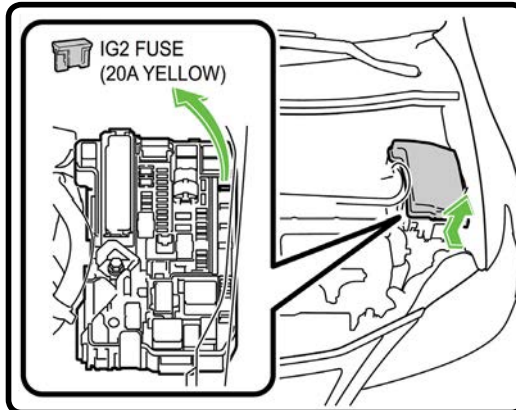

12V Battery in Luggage Compartment



Remove Fuse IG2 in Engine Compartment

WARNINGS

-  NEVER cut, breach, or touch high voltage components or cabling. Doing so could result in serious injury or death.
-  The high voltage system may remain powered for up to 10 minutes after shutoff/disabling. Avoid touching, cutting, or opening any orange high voltage cable or component.
-  Airbags and SRS may remain powered for up to 90 seconds after shutoff/disabling. Avoid breaching SRS components.
-  Lack of engine noise does not mean vehicle is OFF. Silent movement or instant restart capability exists until vehicle is fully shut down.

LEXUS

LEXUS

CT200h

HEV



2014-17

HYBRID







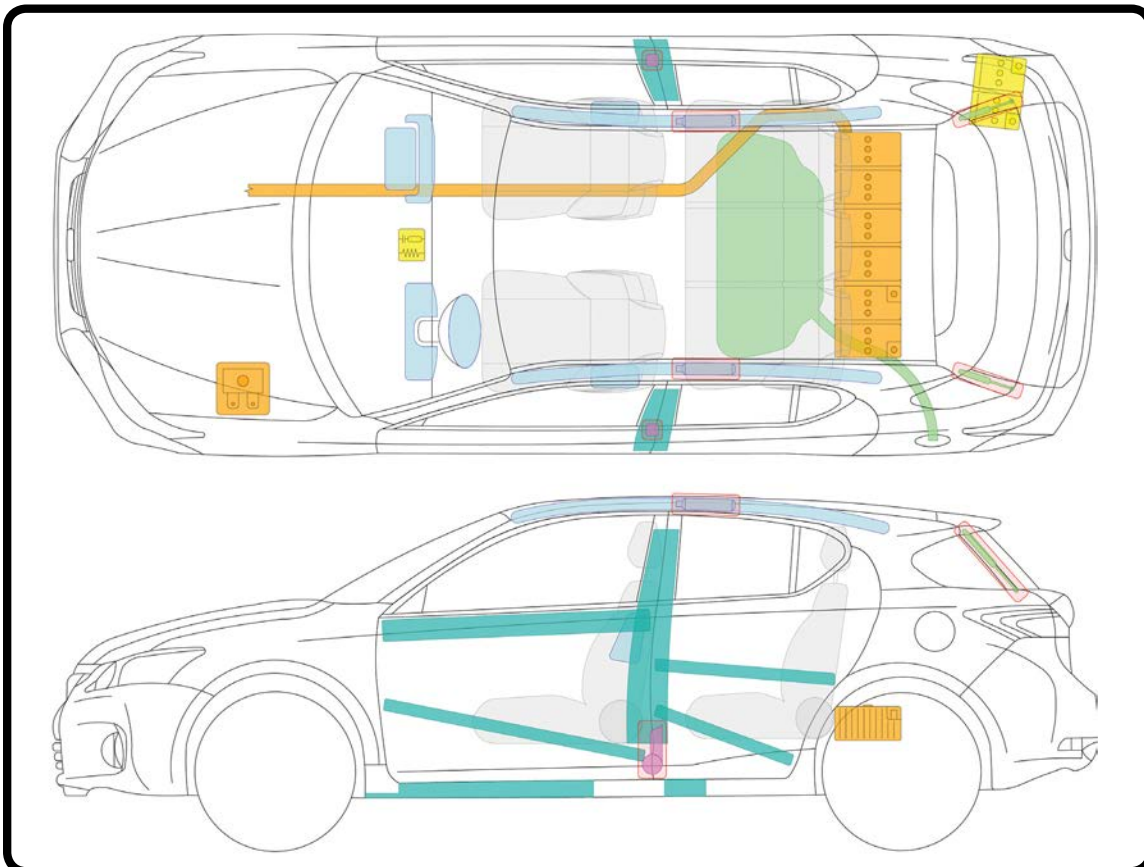



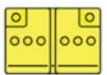

CT200h

(continued) **EXTRICATION INFORMATION**

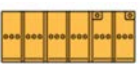

LEGEND

 Airbag	 Bodywork Reinforcements	 SRS Control Unit
 Stored Gas Inflator	 Support Cylinder for Hood	 12V Battery
 Seatbelt Tensioner or Pretensioner	 Fuel Tank	 High-Voltage Power Cable
 High-Voltage Battery	 Emergency Disconnect (Remove Fuse)	

For towing and post-incident instructions, see the **POST-INCIDENT** section on page 20.

LEXUS

LEXUS



2013-18



HYBRID

VEHICLE INFORMATION

IMMOBILIZE VEHICLE

1. Chock the wheels.
2. Set parking brake. (foot pedal)
3. Place vehicle into park. (center console, gear selector)

DISABLE VEHICLE

Determine if vehicle is ON by illumination of READY indicator. The vehicle is OFF if the instrument cluster lights not illuminated.

PRIMARY PROCEDURE

1. If ON, shut off ignition (push-button, right of instrument panel). Remove proximity key and keep it at least 16 feet (5 meters) from vehicle.
2. Disconnect 12V battery (trunk passenger side, auxiliary box).

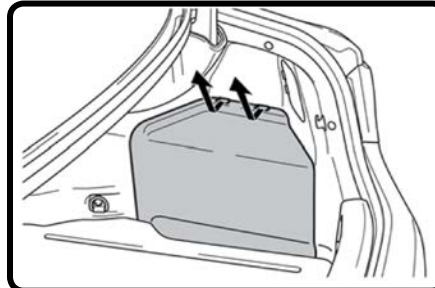

12V Battery in Trunk

ALTERNATE PROCEDURE



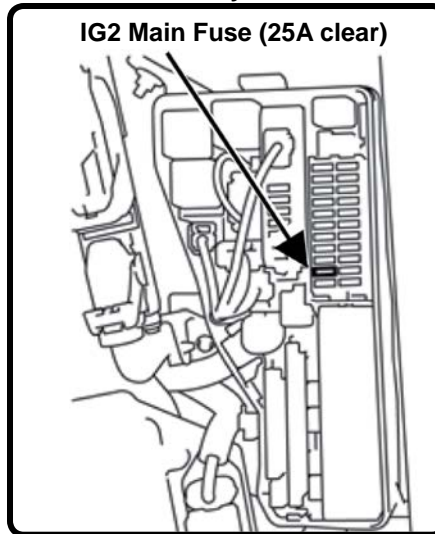

(if power button is inaccessible)

1. Open hood and remove engine compartment fuse box cover (driver's side).
2. Remove IG2 MAIN fuse (25A clear) from the fuse box. If the correct fuse cannot be identified, pull all fuses in fuse box.
3. Disconnect 12V battery (trunk passenger side, auxiliary box).



IG2 MAIN Fuse Located in the Engine Compartment

WARNINGS

-  NEVER cut, breach, or touch high voltage components or cabling. Doing so could result in serious injury or death.
-  The high voltage system may remain powered for up to 10 minutes after the vehicle is shut off.
-  The SRS System (airbags, etc.) may remain powered for up to 90 seconds after disabling.
-  This vehicle may be equipped with a 34V low voltage subsystem. 34V has a higher arc potential than 12V.
-  Lack of engine noise does not mean vehicle is OFF. Silent movement or instant restart capability exists until vehicle is fully shut down.

LEXUS

LEXUS

ES300h

HEV



2013-18



HYBRID

ES300h

(continued) **EXTRICATION INFORMATION**

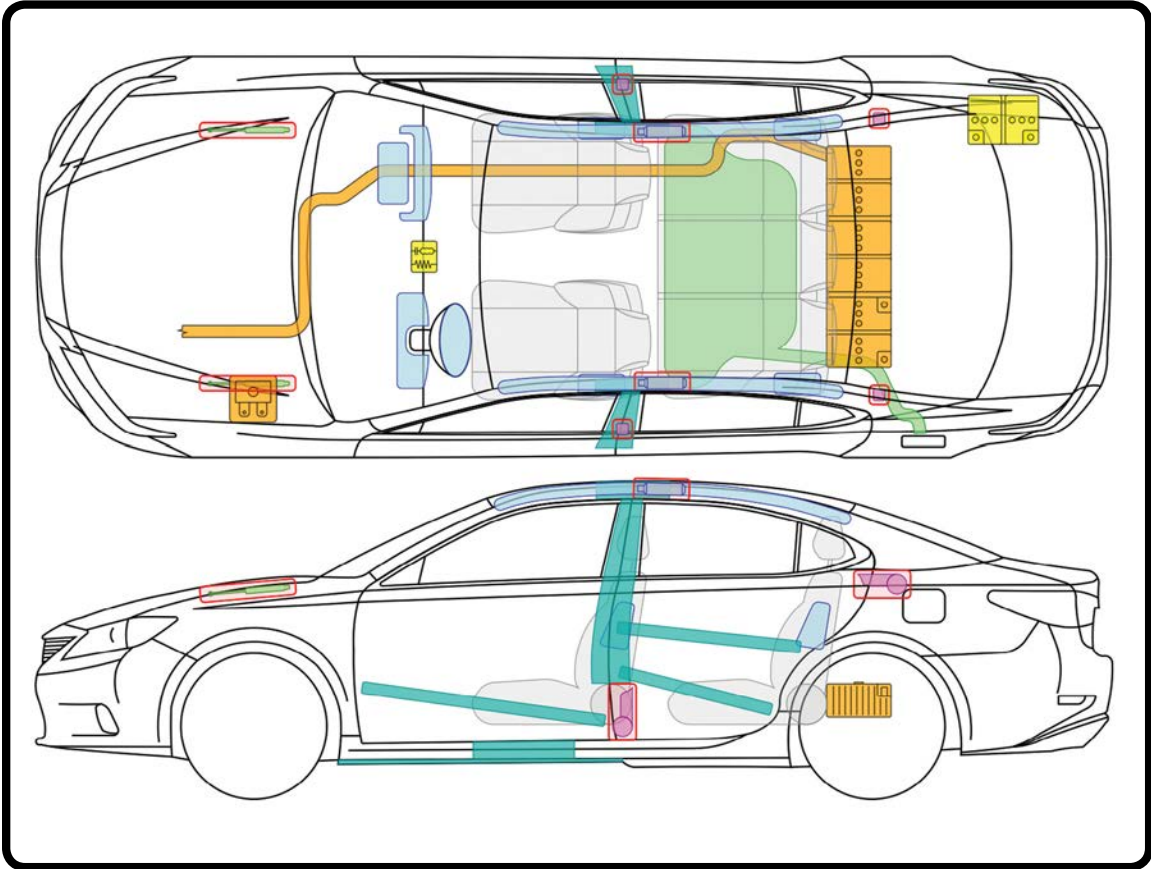

LEGEND

Airbag	Bodywork Reinforcements	SRS Control Unit
Stored Gas Inflator	Support Cylinder for Hood	12V Battery
Seatbelt Tensioner or Pretensioner	Fuel Tank	High-Voltage Power Cable
High-Voltage Battery		

For towing and post-incident instructions, see the **POST-INCIDENT** section on page 20.

LEXUS

LEXUS



2007-11



HYBRID

VEHICLE INFORMATION

IMMOBILIZE VEHICLE

- 1. **Chock the wheels.**
- 2. **Set parking brake.**
(foot pedal)
- 3. **Place vehicle into park.**
(center console)

DISABLE VEHICLE

Determine if vehicle is ON by presence of READY indicator in the instrument cluster.

PRIMARY PROCEDURE

- 1. If ON, turn the vehicle's ignition off (push-button, instrument panel). If the smart key is easily accessible, remove it and keep it at least 16 feet (5 meters) away from the vehicle.
- 2. Disconnect the 12V battery (trunk, driver's side).

ALTERNATE PROCEDURE 1

(if power button is inaccessible)

- 1. Disconnect 12V battery (trunk, driver's side).
- 2. In the engine compartment, remove engine covers and driver's side fuse box cover.
- 3. Remove the IGCT No. 1 fuse (20A yellow) from the fuse box. If the correct fuse cannot be identified, remove them all.

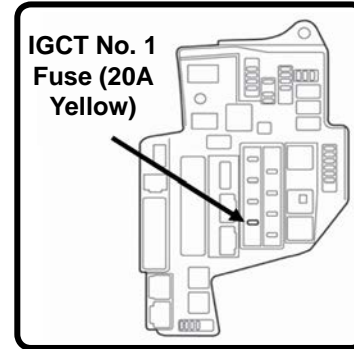

Fuse Box

ALTERNATE PROCEDURE 2

(if power button and engine compartment are inaccessible)

- 1. Remove RH J/B-B fuse (30A green) from the trunk near auxiliary battery positive post. If correct fuse cannot be identified, pull all three.
- 2. Disconnect the 12V battery (trunk, driver's side).

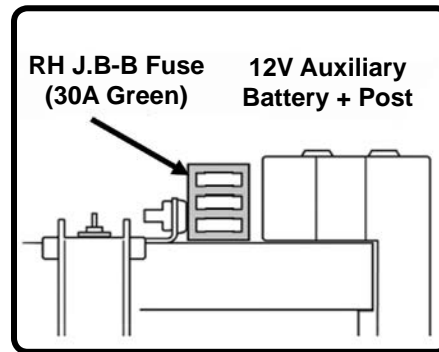

12V Battery Fuse

WARNINGS (continued on the next page)

- NEVER cut, breach, or touch high voltage components or cabling. Doing so could result in serious injury or death.
- The high voltage system may remain powered for up to 10 minutes after shutoff/disabling. Avoid touching, cutting, or opening any orange high voltage cable or component.
- Airbags and SRS may remain powered for up to 90 seconds after shutoff/disabling. Avoid breaching SRS components.
- This vehicle may contain two 12V batteries. The auxiliary battery that controls the low voltage system is located in the trunk, on the driver's side rear quarter panel well. If the optional battery for the active suspension is present, it is located in the spare tire well. The optional battery does not need to be disconnected, but if in doubt, disconnect both.

LEXUS

LEXUS

GS 450h



2007-11

HYBRID



GS 450h

LEXUS

LEXUS

(continued) **EXTRICATION INFORMATION**

WARNINGS (continued)

- High voltage is applied to HID bulb socket when the headlights are on. Do not touch or penetrate bulb socket when headlights are on.
- This vehicle may be equipped with a 37V medium voltage subsystem. 37V has a higher arc potential than 12V.
- Lack of engine noise does not mean vehicle is OFF. Silent movement or instant restart capability exists until vehicle is fully shut down.

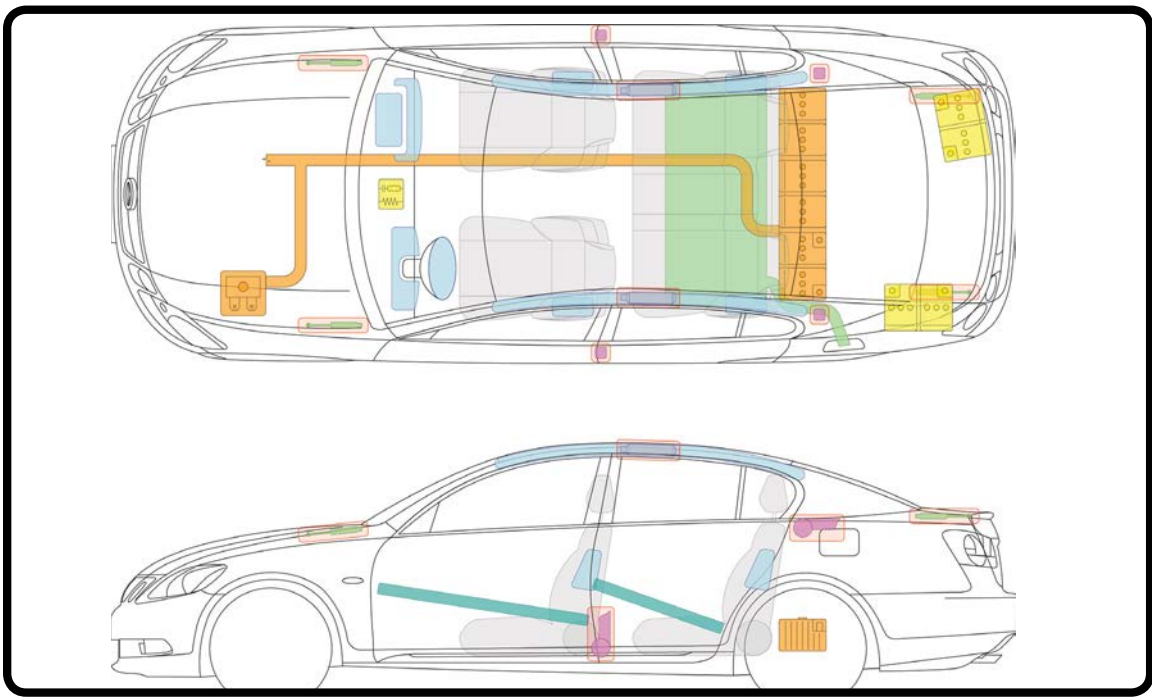

LEGEND		
Airbag	Bodywork Reinforcements	SRS Control Unit
Stored Gas Inflator	Support Cylinder for Hood	12V Battery
Seatbelt Tensioner or Pretensioner	Fuel Tank	High-Voltage Power Cable
High-Voltage Battery	Emergency Disconnect (Remove Fuse)	

For towing and post-incident instructions, see the **POST-INCIDENT** section on page 20.



2013-15



2016-18

2013-18

HYBRID



VEHICLE INFORMATION

IMMOBILIZE VEHICLE

1. **Chock the wheels.**
2. **Set parking brake.**
(push parking brake switch, right of the steering column)
3. **Place vehicle into park.**
(center console)

DISABLE VEHICLE

Determine if vehicle is ON by presence of READY indicator in the instrument cluster. If the vehicle is shut off, the instrument cluster gauges will not be illuminated.

PRIMARY PROCEDURE

1. If ON, turn the vehicle's ignition off (push-button, instrument panel). If the smart key is easily accessible, remove it and keep it at least 16 feet (5 meters) away from the vehicle.
2. Disconnect the 12V battery (trunk, driver's side).

ALTERNATE PROCEDURE

(if power button is inaccessible)

1. In the engine compartment, remove the driver's side fuse box cover.
2. Remove the IG2 MAIN fuse (20A yellow) from the fuse box. If the correct fuse cannot be identified, remove them all.
3. Disconnect 12V battery (trunk, driver's side).

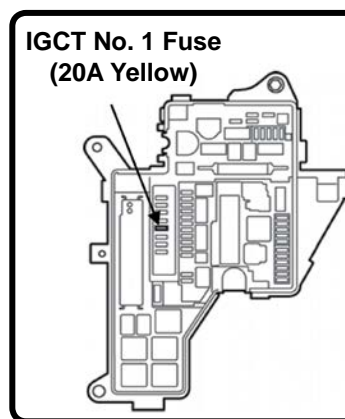

Fuse Box

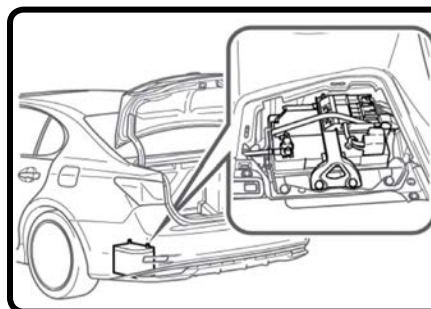

12V Battery Location

WARNINGS

- NEVER cut, breach, or touch high voltage components or cabling. Doing so could result in serious injury or death.
- The high voltage system may remain powered for up to 10 minutes after shutoff/disabling. Avoid touching, cutting, or opening any orange high voltage cable or component.
- Airbags and SRS may remain powered for up to 90 seconds after shutoff/disabling. Avoid breaching SRS components.
- This vehicle may be equipped with a 46V medium voltage subsystem. 46V has a higher arc potential than 12V.
- Lack of engine noise does not mean vehicle is OFF. Silent movement or instant restart capability exists until vehicle is fully shut down.

LEXUS

LEXUS

GS 450h

HEV



2013-18









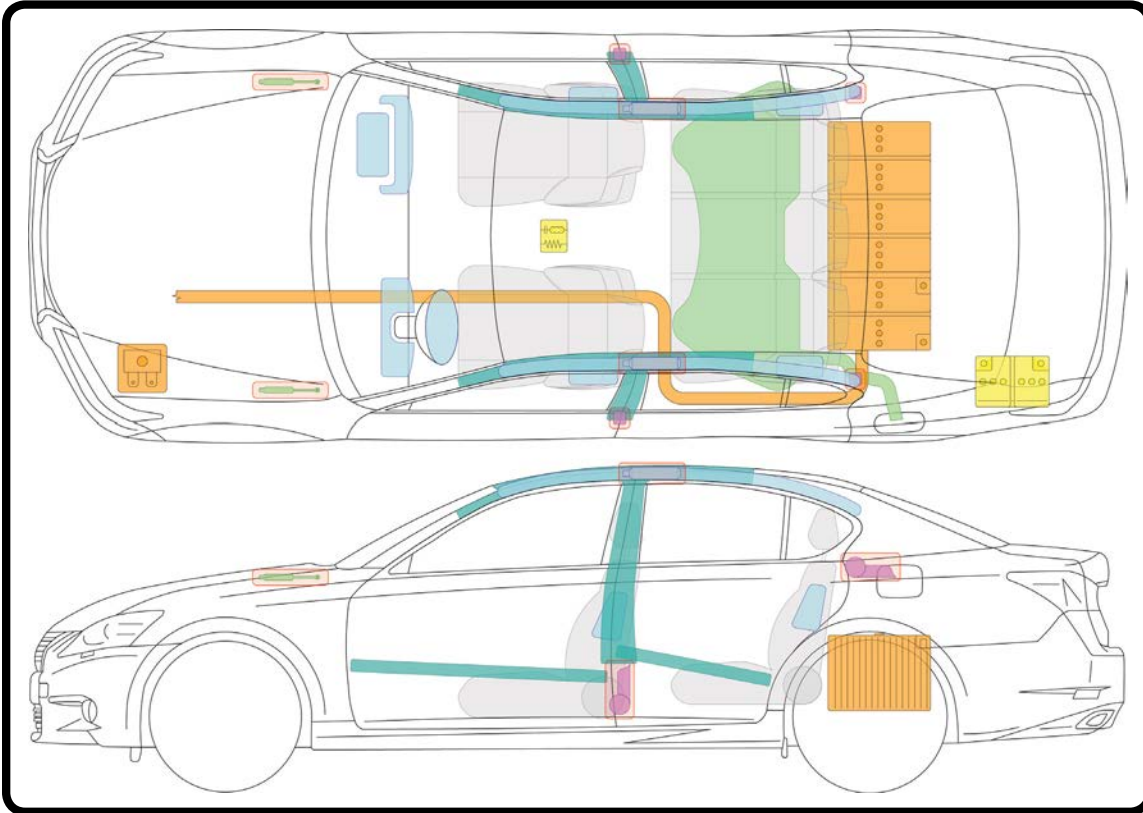

HYBRID

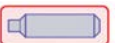
GS 450h

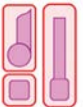
(continued) **EXTRICATION INFORMATION**



LEGEND		
 Airbag	 Bodywork Reinforcements	 SRS Control Unit
 Stored Gas Inflator	 Support Cylinder for Hood	 12V Battery
 Seatbelt Tensioner or Pretensioner	 Fuel Tank	 High-Voltage Power Cable
 High-Voltage Battery	 Emergency Disconnect (Remove Fuse)	

For towing and post-incident instructions, see the **POST-INCIDENT** section on page 20.

LEXUS

LEXUS



2010-12



HYBRID

VEHICLE INFORMATION

IMMOBILIZE VEHICLE

- 1. **Chock the wheels.**
- 2. **Set parking brake.**
(foot pedal)
- 3. **Place vehicle into park.**
(push-button, center console)

DISABLE VEHICLE

Determine if vehicle is ON by illumination of READY light. Vehicle is OFF if instrument cluster is "blacked out".

PRIMARY PROCEDURE

- 1. If ON, turn the vehicle's ignition off (push-button, instrument panel). If the smart key is easily accessible, keep it at least 16 feet (5 meters) away from the vehicle.
- 2. Disconnect the 12V battery (trunk, driver's side).

ALTERNATE PROCEDURE

(if power button is inaccessible)

- 1. Remove underhood fuse box cover.
- 2. Remove IGCT No. 2 fuse (10A red) from the engine compartment fuse box. If the correct fuse cannot be identified, pull all of the fuses in fuse box.
- 3. Disconnect 12V auxiliary battery (trunk).

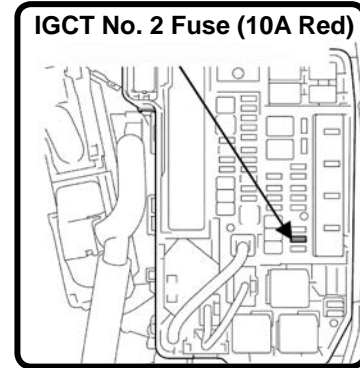

Fuse Box

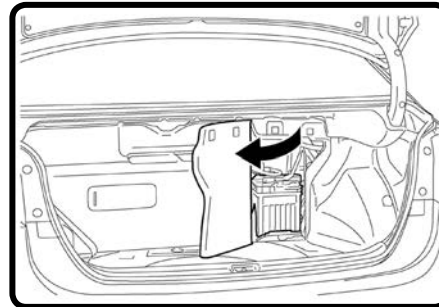

12V Battery Location

WARNINGS

- NEVER cut, breach, or touch high voltage components or cabling. Doing so could result in serious injury or death.
- The high voltage system may remain powered for up to 10 minutes after shutoff/disabling. Avoid touching, cutting, or opening any orange high voltage cable or component.
- Airbags and SRS may remain powered for up to 90 seconds after shutoff/disabling. Avoid breaching SRS components.
- Lack of engine noise does not mean vehicle is OFF. Silent movement or instant restart capability exists until vehicle is fully shut down.

LEXUS

LEXUS

ES250h

HEV



2010-12









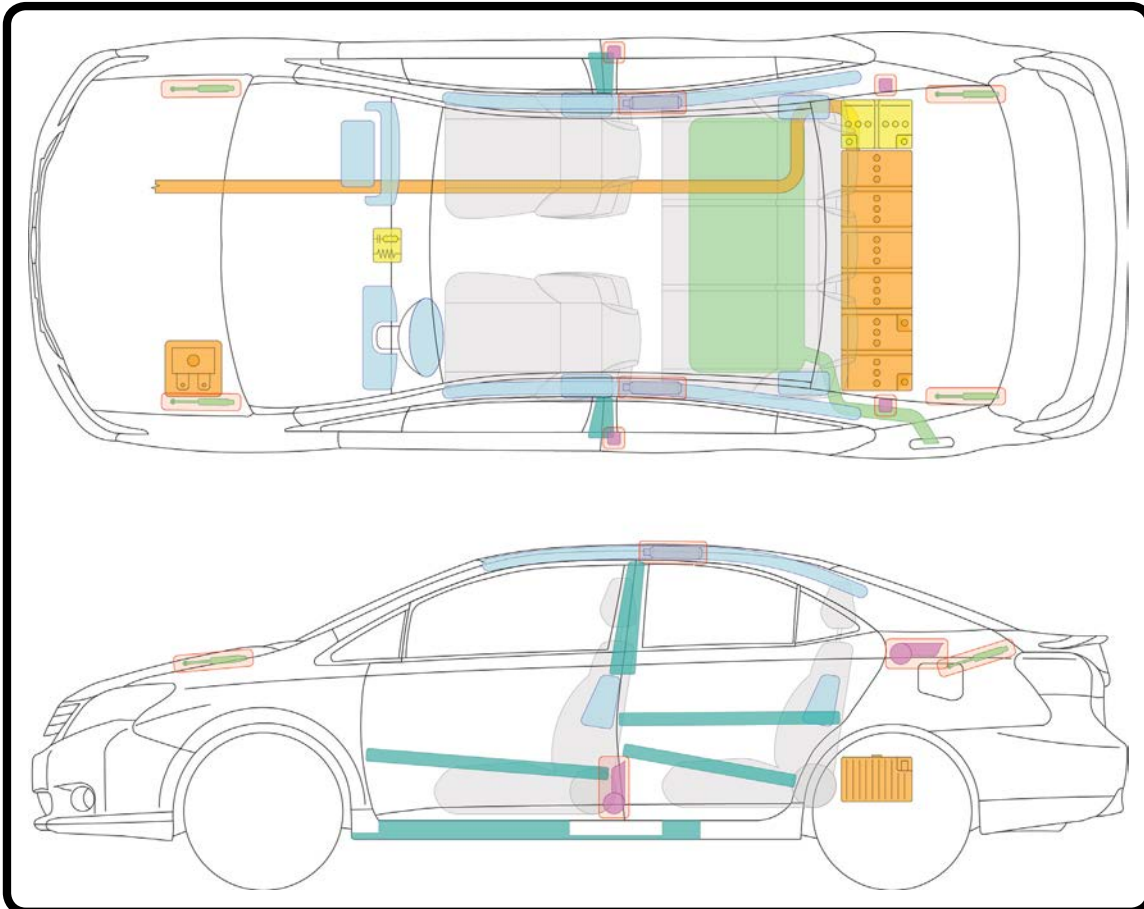

HYBRID

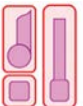

HS250H

(continued) **EXTRICATION INFORMATION**

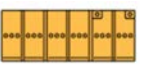

LEGEND		
 Airbag	 Bodywork Reinforcements	 SRS Control Unit
 Stored Gas Inflator	 Support Cylinder for Hood	 12V Battery
 Seatbelt Tensioner or Pretensioner	 Fuel Tank	 High-Voltage Power Cable
 High-Voltage Battery	 Emergency Disconnect (Remove Fuse)	

For towing and post-incident instructions, see the **POST-INCIDENT** section on page 20.

LEXUS

LEXUS



2018



MULTI STAGE
HYBRID

VEHICLE INFORMATION

Li-ion

See pages 15, 22.

IMMOBILIZE VEHICLE

1. **Chock the wheels.**
2. **Set parking brake.**
(push-button, to the right of steering column)
3. **Place vehicle into park.**
(push-button below gear selector, center console)

DISABLE VEHICLE

Determine if vehicle is ON by illumination of READY light.

PRIMARY PROCEDURE

1. If ON, shut off ignition (push-button, right of instrument panel).
2. Remove proximity key and keep it at least 16 feet (5 meters) from vehicle.
3. Disconnect negative 12V battery cable (under luggage compartment floorboard).

ALTERNATE PROCEDURE

(if power button is inaccessible)

1. Open trunk and remove fuse box cover (under luggage compartment floorboard).
2. Remove J/B D-B fuse (40A pink) from the fuse box. If the correct fuse cannot be identified, pull all fuses in fuse box.
3. Disconnect negative 12V battery cable (under luggage compartment floorboard).

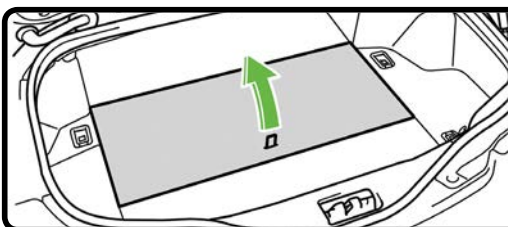

Luggage Compartment

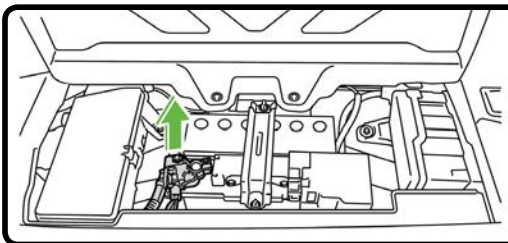



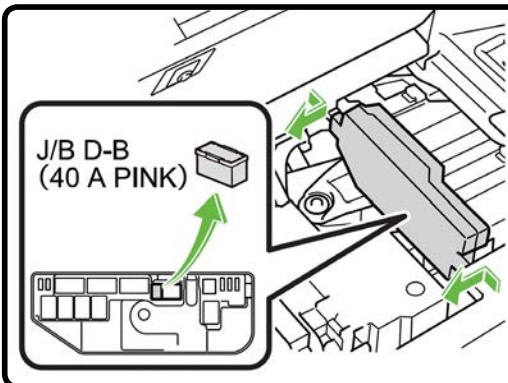

12V Battery Luggage Compartment



Remove J/B D-B (40A pink) Fuse in Trunk

WARNINGS

-  NEVER cut, breach, or touch high voltage components or cabling. Doing so could result in serious injury or death.
-  The high voltage system may remain powered for up to 10 minutes after shutoff/disabling. Avoid touching, cutting, or opening any orange high voltage cable or component.
-  Airbags and SRS may remain powered for up to 90 seconds after shutoff/disabling. Avoid breaching SRS components.
-  Lack of engine noise does not mean vehicle is OFF. Silent movement or instant restart capability exists until vehicle is fully shut down.

LEXUS

LEXUS

LC500h



2018









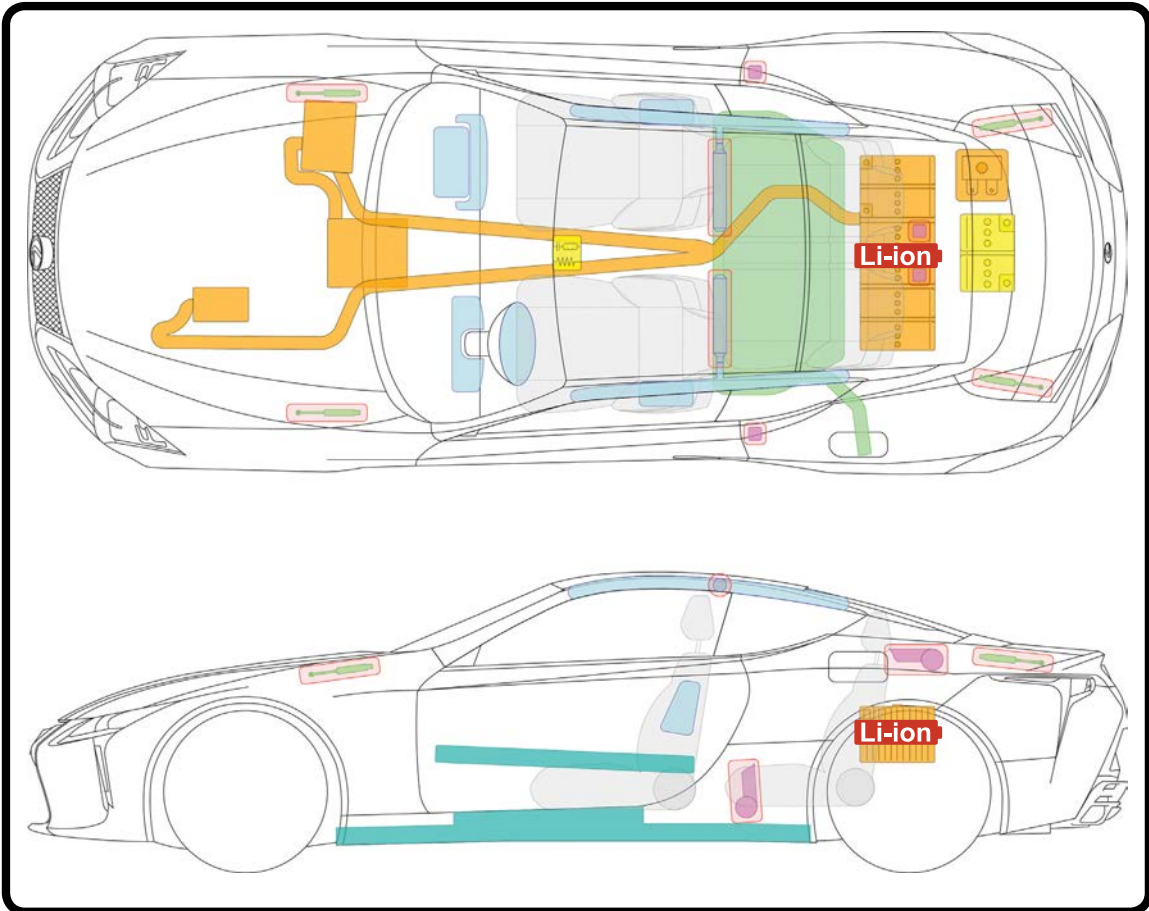



ES300h

Li-ion (continued) **EXTRICATION INFORMATION**

See pages 15, 22.

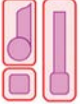

LEGEND

 Airbag	 Bodywork Reinforcements	 SRS Control Unit
 Stored Gas Inflator	 Support Cylinder for Hood	 12V Battery
 Seatbelt Tensioner or Pretensioner	 Fuel Tank	 High-Voltage Power Cable
 High-Voltage Battery	 Emergency Disconnect (Remove Fuse)	

For towing and post-incident instructions, see the **POST-INCIDENT** section on page 20.



2018



MULTI STAGE
HYBRID

VEHICLE INFORMATION

Li-ion

See pages 15, 22.

IMMOBILIZE VEHICLE

1. **Chock the wheels.**
2. **Set parking brake.**
(push-button, to the right of steering column)
3. **Place vehicle into park.**
(gear selector, center console)

DISABLE VEHICLE

Determine if vehicle is ON by illumination of READY light.

PRIMARY PROCEDURE

1. If ON, shut off ignition (push-button, right of instrument panel).
2. Remove proximity key and keep it at least 16 feet (5 meters) from vehicle.
3. Disconnect negative 12V battery cable (under luggage compartment floorboard).

ALTERNATE PROCEDURE

(if power button is inaccessible)

1. Open trunk and remove fuse box cover (under luggage compartment floorboard).
2. Remove IGCT NO.1 fuse (30A green) from the fuse box. If the correct fuse cannot be identified, pull all fuses in fuse box.
3. Disconnect negative 12V battery cable (under luggage compartment floorboard).

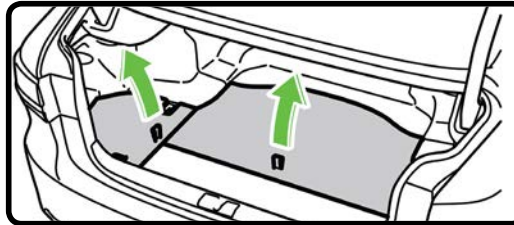

Luggage Compartment

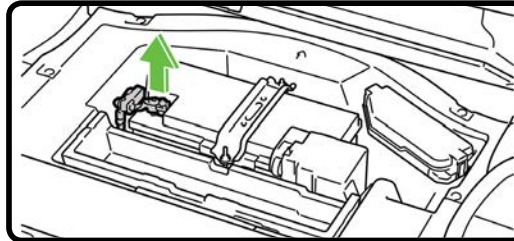



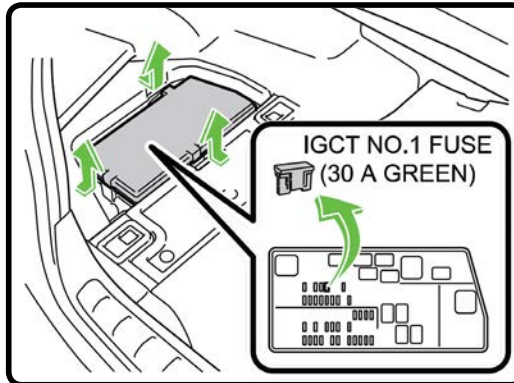

12V Battery Luggage Compartment



Remove IGCT NO. 1 (30A green) Fuse

WARNINGS

-  NEVER cut, breach, or touch high voltage components or cabling. Doing so could result in serious injury or death.
-  The high voltage system may remain powered for up to 10 minutes after shutoff/disabling. Avoid touching, cutting, or opening any orange high voltage cable or component.
-  Airbags and SRS may remain powered for up to 90 seconds after shutoff/disabling. Avoid breaching SRS components.
-  Lack of engine noise does not mean vehicle is OFF. Silent movement or instant restart capability exists until vehicle is fully shut down.

LEXUS

LEXUS

LS 500h



2018









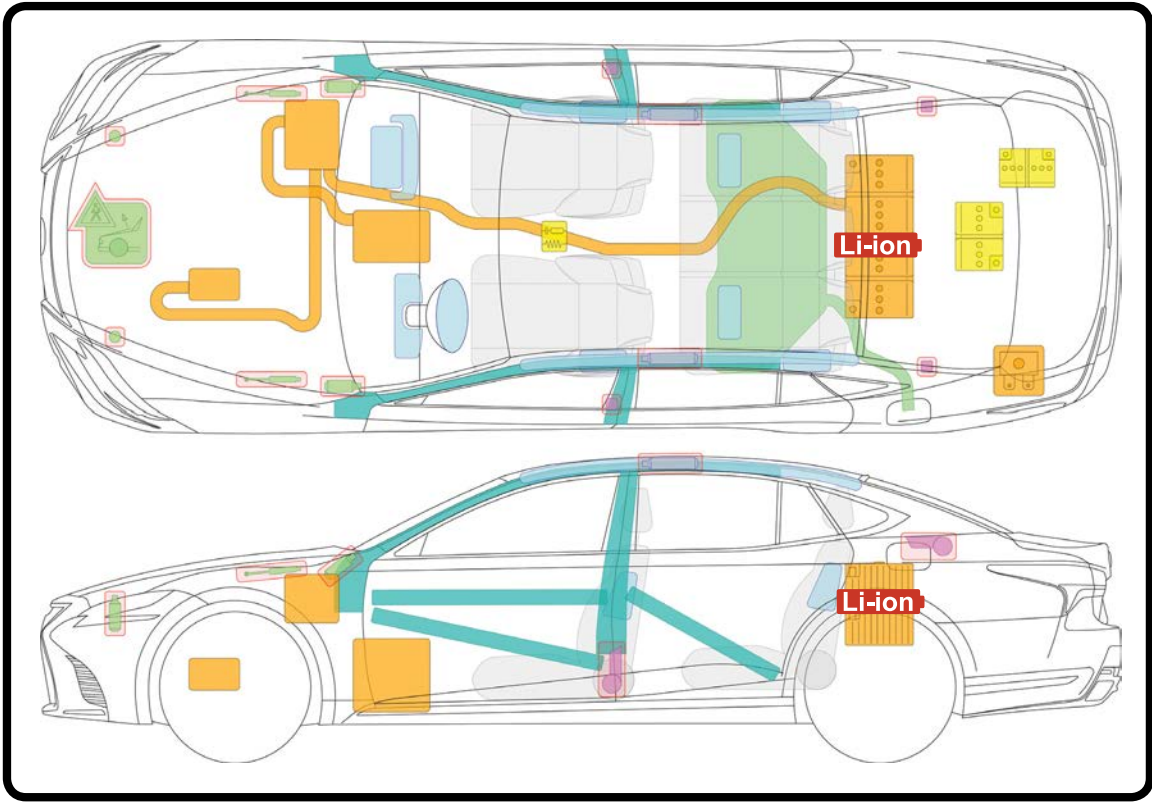



LEXUS LS500h

Li-ion (continued) **EXTRICATION INFORMATION**

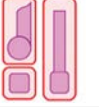
See pages 15, 22.



LEGEND		
 Airbag	 Bodywork Reinforcements	 SRS Control Unit
 Stored Gas Inflator	 Support Cylinder for Hood	 12V Battery
 Seatbelt Tensioner or Pretensioner	 Fuel Tank	 High-Voltage Power Cable
 High-Voltage Battery	 Emergency Disconnect (Remove Fuse)	

For towing and post-incident instructions, see the **POST-INCIDENT** section on page 20.

LEXUS



2008-09

2008-16

HYBRID



VEHICLE INFORMATION

IMMOBILIZE VEHICLE

1. **Chock the wheels.**
2. **Set parking brake.** (push-button, to the right of steering column)
3. **Place vehicle into park** (center console)

DISABLE VEHICLE

Determine if vehicle is ON by illumination of READY light. Vehicle is OFF if instrument cluster is "blacked out".

PRIMARY PROCEDURE

1. If ON, turn the vehicle's ignition off (push-button, instrument panel). If the smart key is easily accessible, keep it at least 16 feet (5 meters) away from the vehicle.
2. Disconnect the 12V battery (trunk, driver's side).

ALTERNATE PROCEDURE

(if power button is inaccessible)

1. Remove passenger's side engine cover then underhood fuse box cover.
2. Remove IG 2 relay (fuse) from the engine compartment fuse box. If correct relay cannot be identified, pull both relays in fuse box.
3. Disconnect 12V battery (trunk, driver's side).

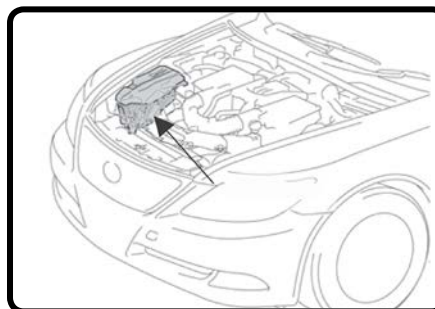



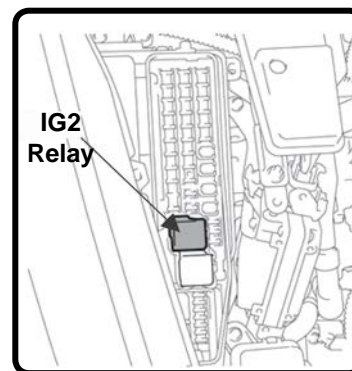

Fuse Box Location



Fuse Location

WARNINGS

-  NEVER cut, breach, or touch high voltage components or cabling. Doing so could result in serious injury or death.
-  The high voltage system may remain powered for up to 10 minutes after shutoff/disabling. Avoid touching, cutting, or opening any orange high voltage cable or component.
-  Airbags and SRS may remain powered for up to 90 seconds after shutoff/disabling. Avoid breaching SRS components.
-  This vehicle may be equipped with a 46V medium voltage subsystem indicated by dull yellow cabling. 46V has a higher arc potential than 12V.
-  Lack of engine noise does not mean vehicle is OFF. Silent movement or instant restart capability exists until vehicle is fully shut down.

LEXUS

LEXUS

ES 600h L

HEV



2008-16

HYBRID







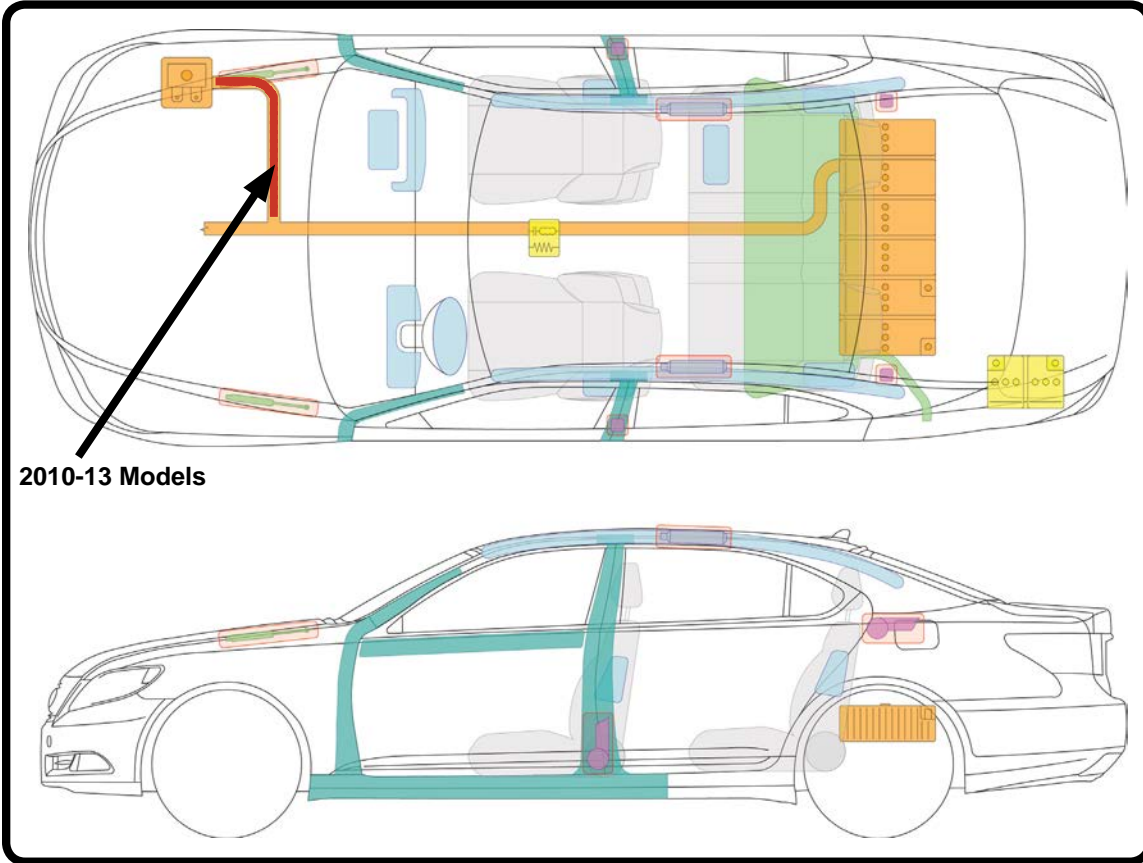



2008-09

(continued) **EXTRICATION INFORMATION**

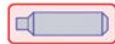

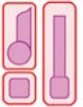
2010-13 Models

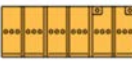
LEGEND

 Airbag	 Bodywork Reinforcements	 SRS Control Unit
 Stored Gas Inflator	 Support Cylinder for Hood	 12V Battery
 Seatbelt Tensioner or Pretensioner	 Fuel Tank	 High-Voltage Power Cable
 High-Voltage Battery	 Emergency Disconnect (Remove Fuse)	

For towing and post-incident instructions, see the **POST-INCIDENT** section on page 20.

LEXUS ES 350

LEXUS

LEXUS ES 350



2010-12

2008-16

HYBRID



VEHICLE INFORMATION

SPECIAL CONCERNS – IDENTIFICATION

2008-09



HYBRID

2010-12



HYBRID

2013-16



HYBRID

LEXUS

LEXUS

LS600hL

HEV



2008-16

HYBRID



2010-12

LEXUS ES 350

LEXUS

LEXUS

THIS PAGE INTENTIONALLY LEFT BLANK



2015-18



HYBRID

VEHICLE INFORMATION

IMMOBILIZE VEHICLE

1. **Chock the wheels.**
2. **Set parking brake.**
(push/pull switch, center console)
3. **Place vehicle into park.**
(gear selector, center console)

DISABLE VEHICLE

Determine if vehicle is ON by illumination of READY light.

PRIMARY PROCEDURE

1. If ON, shut off ignition (push-button, right of instrument panel).
2. Remove proximity key and keep it at least 16 feet (5 meters) from vehicle.
3. Disconnect negative 12V battery cable (under luggage compartment floorboard, driver's side).

ALTERNATE PROCEDURE

(if power button is inaccessible)

1. Open hood and remove engine compartment fuse box cover (driver's side).
2. Remove IG2-MAIN fuse (20A yellow) from the fuse box. If the correct fuse cannot be identified, pull all fuses in fuse box.
3. Disconnect negative 12V battery cable (under luggage compartment floorboard, driver's side).

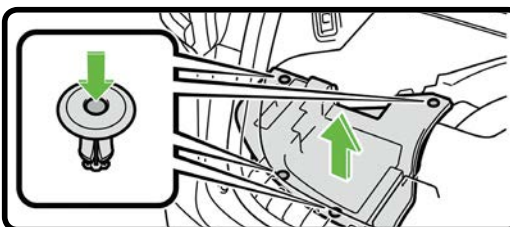

Luggage Compartment

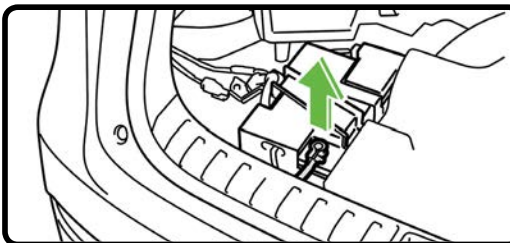

12V Battery Luggage Compartment

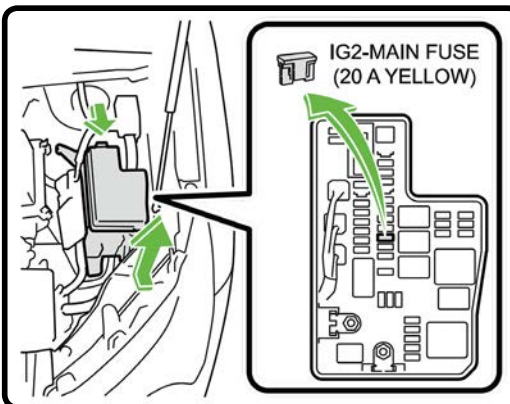

Remove IG2-MAIN (20A yellow) Fuse

WARNINGS

- NEVER cut, breach, or touch high voltage components or cabling. Doing so could result in serious injury or death.
- The high voltage system may remain powered for up to 10 minutes after shutoff/disabling. Avoid touching, cutting, or opening any orange high voltage cable or component.
- Airbags and SRS may remain powered for up to 90 seconds after shutoff/disabling. Avoid breaching SRS components.
- Lack of engine noise does not mean vehicle is OFF. Silent movement or instant restart capability exists until vehicle is fully shut down.

LEXUS

LEXUS

NX300h

HEV



2015-18



NX300h

(continued) **EXTRICATION INFORMATION**

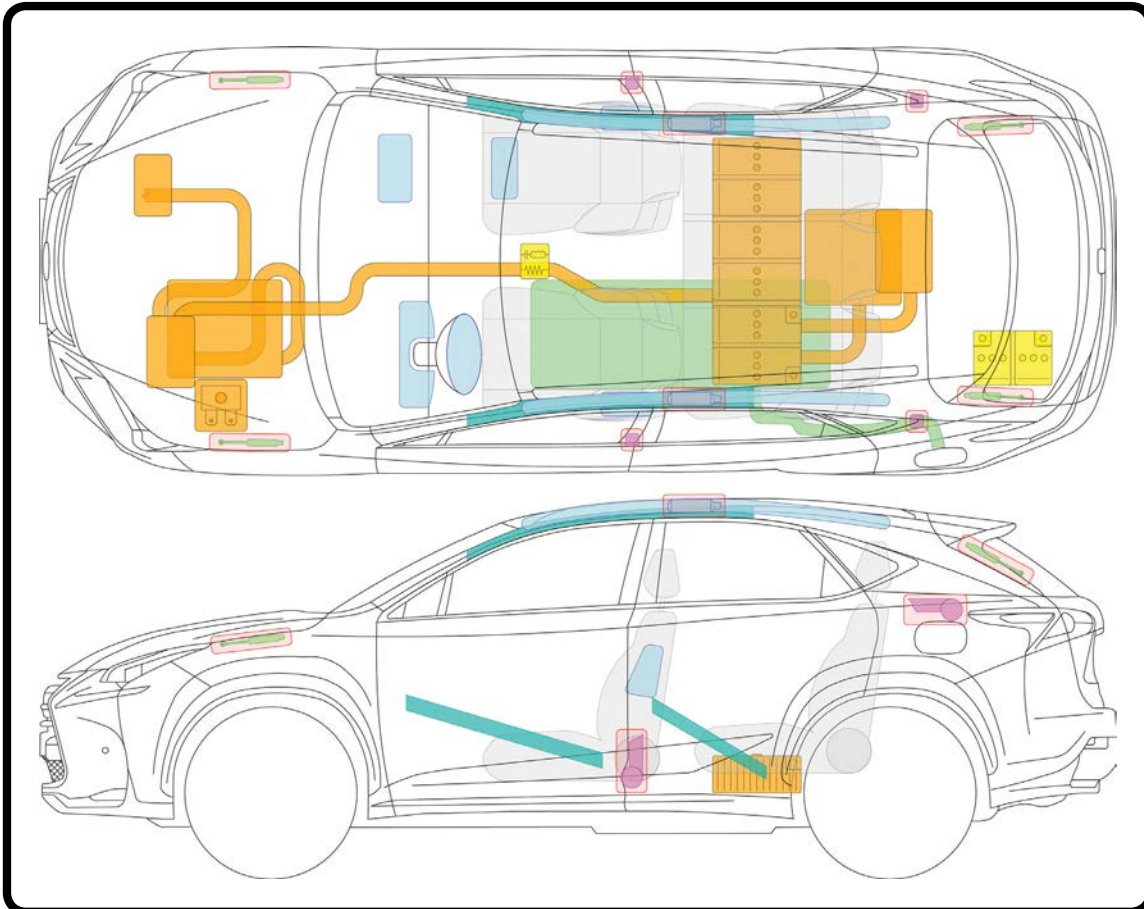

LEGEND		
Airbag	Bodywork Reinforcements	SRS Control Unit
Stored Gas Inflator	Support Cylinder for Hood	12V Battery
Seatbelt Tensioner or Pretensioner	Fuel Tank	High-Voltage Power Cable
High-Voltage Battery	Emergency Disconnect (Remove Fuse)	

For towing and post-incident instructions, see the **POST-INCIDENT** section on page 20.

LEXUS

LEXUS



2006-08



VEHICLE INFORMATION

IMMOBILIZE VEHICLE

- 1. **Chock the wheels.**
- 2. **Set parking brake.**
(foot pedal)
- 3. **Place vehicle into park.**
(center console)

DISABLE VEHICLE

PRIMARY PROCEDURE

- 1. If ON, turn the vehicle's ignition off (key, steering column). Remove key.
- 2. Disconnect the 12V battery (engine compartment).

ALTERNATE PROCEDURE

(if key is inaccessible)

- 1. Disconnect the 12V battery (engine compartment).
- 2. Open the hood and remove engine cover.
- 3. Remove the IGCT No. 4 fuse (10A red colored) in the engine compartment fuse box (refer to illustration).
- 4. If the correct fuse cannot be identified, pull all fuses in the fuse box.

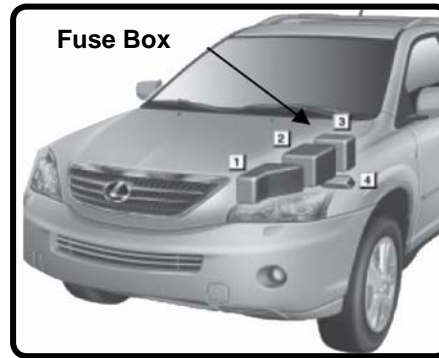



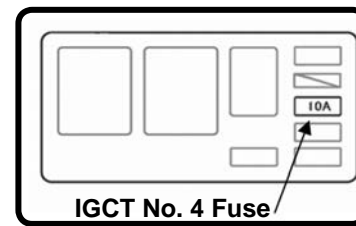

Fuse Box Location



Fuse Location

WARNINGS

-  NEVER cut, breach, or touch high voltage components or cabling. Doing so could result in serious injury or death.
-  The high voltage system may remain powered for up to 5 minutes after shutoff/disabling. Avoid touching, cutting, or opening any orange high voltage cable or component.
-  Airbags and SRS may remain powered for up to 90 seconds after shutoff/disabling. Avoid breaching SRS components.
-  This vehicle may be equipped with a 42V medium voltage subsystem indicated by yellow cabling. 42V has a higher arc potential than 12V.
-  Lack of engine noise does not mean vehicle is OFF. Silent movement or instant restart capability exists until vehicle is fully shut down.

LEXUS

LEXUS

RX 400h

HEV



2006-08







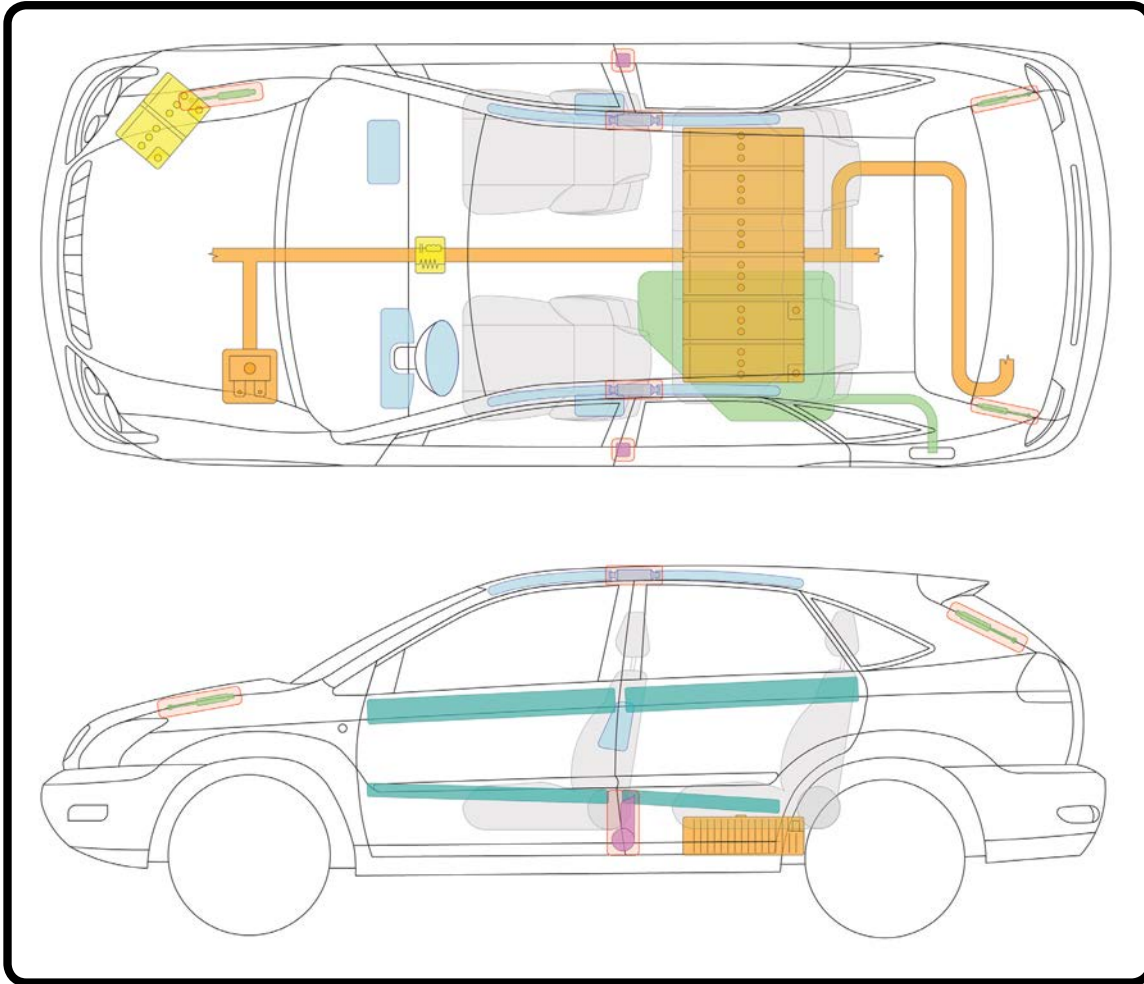

400h

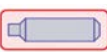

LEXUS RX 400h

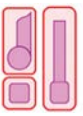
(continued) **EXTRICATION INFORMATION**



LEGEND		
 Airbag	 Bodywork Reinforcements	 SRS Control Unit
 Stored Gas Inflator	 Support Cylinder for Hood	 12V Battery
 Seatbelt Tensioner or Pretensioner	 Fuel Tank	 High-Voltage Power Cable
 High-Voltage Battery	 Emergency Disconnect (Remove Fuse)	

For towing and post-incident instructions, see the **POST-INCIDENT** section on page 20.

LEXUS

LEXUS



2010-15



HYBRID

VEHICLE INFORMATION

IMMOBILIZE VEHICLE

1. Chock the wheels.
2. Set parking brake. (foot pedal)
3. Place vehicle into park. (center console)

DISABLE VEHICLE

Determine if vehicle is ON by presence of READY indicator in the instrument cluster.

PRIMARY PROCEDURE

1. If ON, turn the vehicle's ignition off (push button). If the smart key is easily accessible, remove it and keep it at least 16 feet (5 meters) away from the vehicle.
2. Disconnect the 12V battery (cargo area, driver's side).

ALTERNATE PROCEDURE

(if power button is inaccessible)

1. Open hood, remove engine cover and fuse box cover.
2. Remove IG2 MAIN fuse (30A green) from fuse box. If correct fuse cannot be identified, pull all fuses in fuse box.
3. Disconnect 12V battery in cargo area (driver's side).

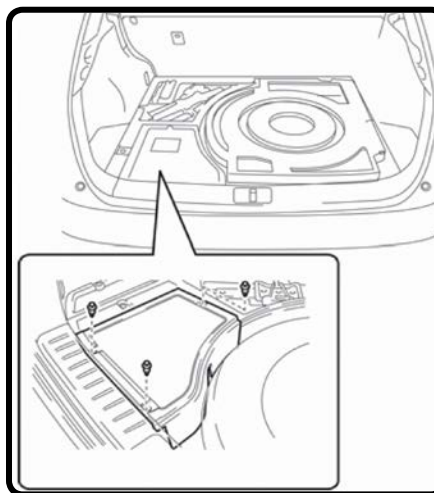

Auxiliary Battery Location

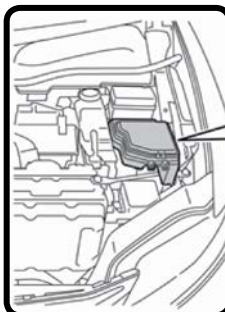



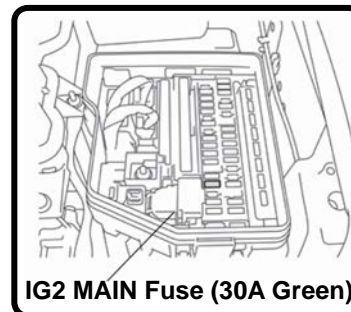

Fuse Box Location



IG2 MAIN Fuse (30A Green)

Fuse Location

WARNINGS

-  NEVER cut, breach, or touch high voltage components or cabling. Doing so could result in serious injury or death.
-  The high voltage system may remain powered for up to 10 minutes after shutoff/disabling. Avoid touching, cutting, or opening any orange high voltage cable or component.
-  Airbags and SRS may remain powered for up to 90 seconds after shutoff/disabling. Avoid breaching SRS components.
-  This vehicle may be equipped with a 46V medium voltage subsystem. 46V has a higher arc potential than 12V.
-  Lack of engine noise does not mean vehicle is OFF. Silent movement or instant restart capability exists until vehicle is fully shut down.

LEXUS

LEXUS

RX 450h

HEV



2010-15

HYBRID











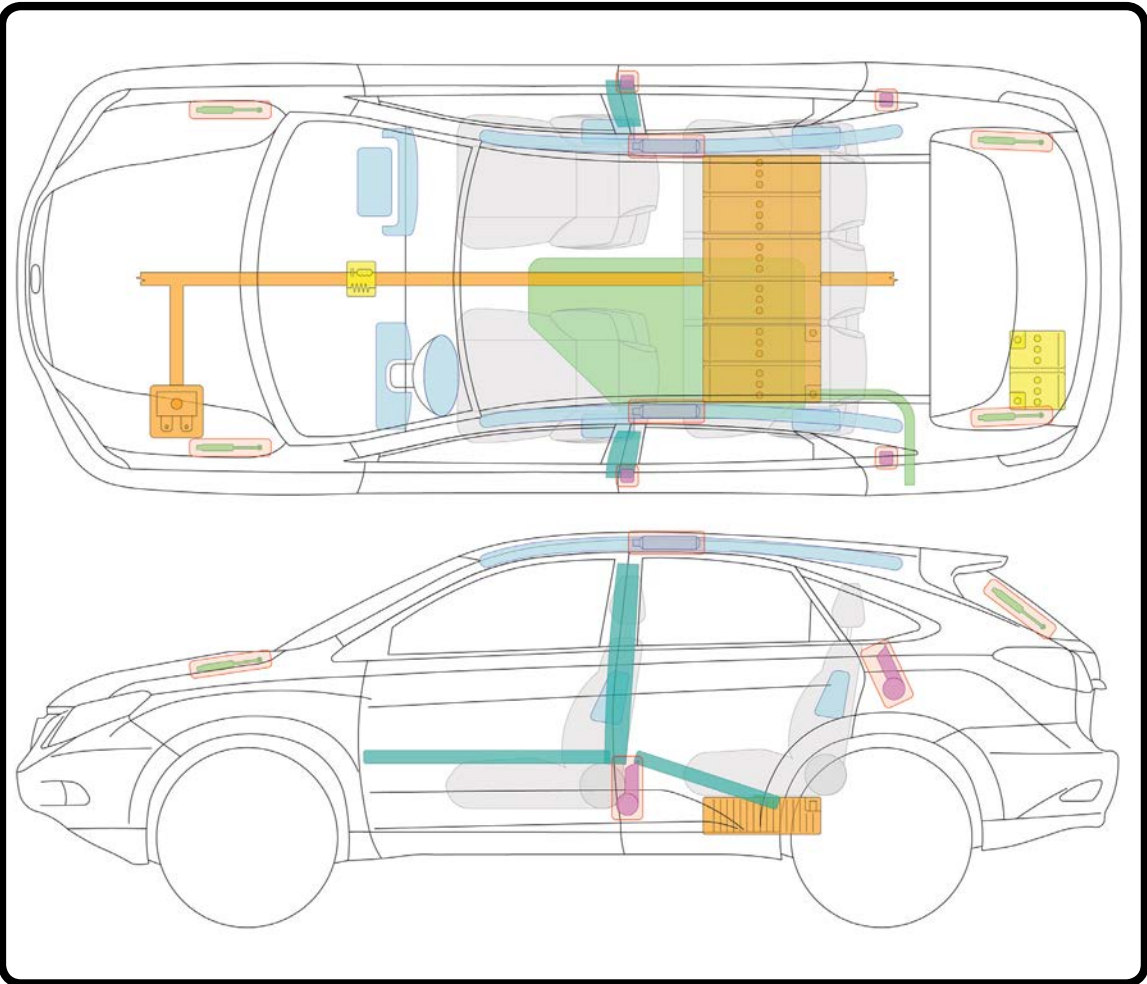

LEXUS RX450h

LEXUS

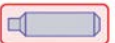
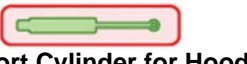
LEXUS

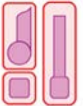
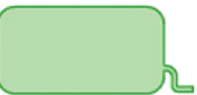
(continued) **EXTRICATION INFORMATION**



LEGEND		
 Airbag	 Bodywork Reinforcements	 SRS Control Unit
 Stored Gas Inflator	 Support Cylinder for Hood	 12V Battery
 Seatbelt Tensioner or Pretensioner	 Fuel Tank	 High-Voltage Power Cable
 High-Voltage Battery	 Emergency Disconnect (Remove Fuse)	

For towing and post-incident instructions, see the **POST-INCIDENT** section on page 20.



2016-18



HYBRID

VEHICLE INFORMATION

IMMOBILIZE VEHICLE

- 1. **Chock the wheels.**
- 2. **Set parking brake.**
(push/pull switch, center console)
- 3. **Place vehicle into park.**
(gear selector, center console)

DISABLE VEHICLE

Determine if vehicle is ON by illumination of READY light.

PRIMARY PROCEDURE

- 1. If ON, shut off ignition (push-button, right of instrument panel).
- 2. Remove proximity key and keep it at least 16 feet (5 meters) from vehicle.
- 3. Disconnect negative 12V battery cable (under luggage compartment floorboard).

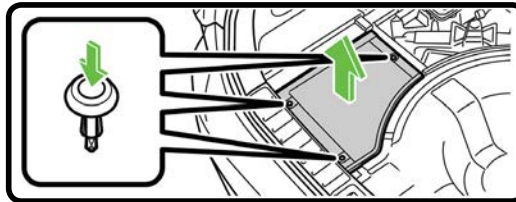

Luggage Compartment

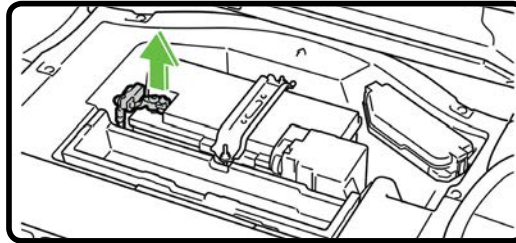

12V Battery Luggage Compartment

ALTERNATE PROCEDURE

(if power button is inaccessible)

- 1. Open hood and remove engine compartment fuse box cover (driver's side).
- 2. Remove IG2-MAIN fuse (20A yellow) from the fuse box. If the correct fuse cannot be identified, pull all fuses in fuse box.
- 3. Disconnect negative 12V battery cable (under luggage compartment floorboard).

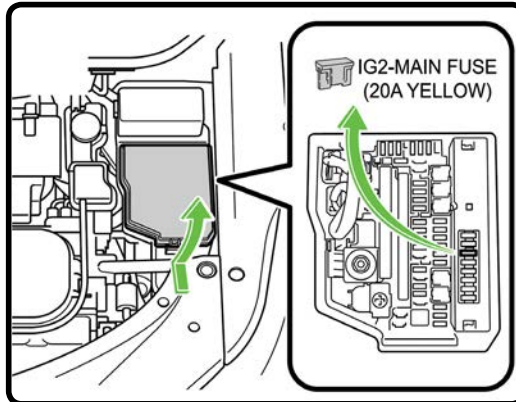

Remove IG2-MAIN (20A yellow) Fuse

WARNINGS

- NEVER cut, breach, or touch high voltage components or cabling. Doing so could result in serious injury or death.
- The high voltage system may remain powered for up to 10 minutes after shutoff/disabling. Avoid touching, cutting, or opening any orange high voltage cable or component.
- Airbags and SRS may remain powered for up to 90 seconds after shutoff/disabling. Avoid breaching SRS components.
- Lack of engine noise does not mean vehicle is OFF. Silent movement or instant restart capability exists until vehicle is fully shut down.

LEXUS

LEXUS

RX 450h

HEV



2016-18







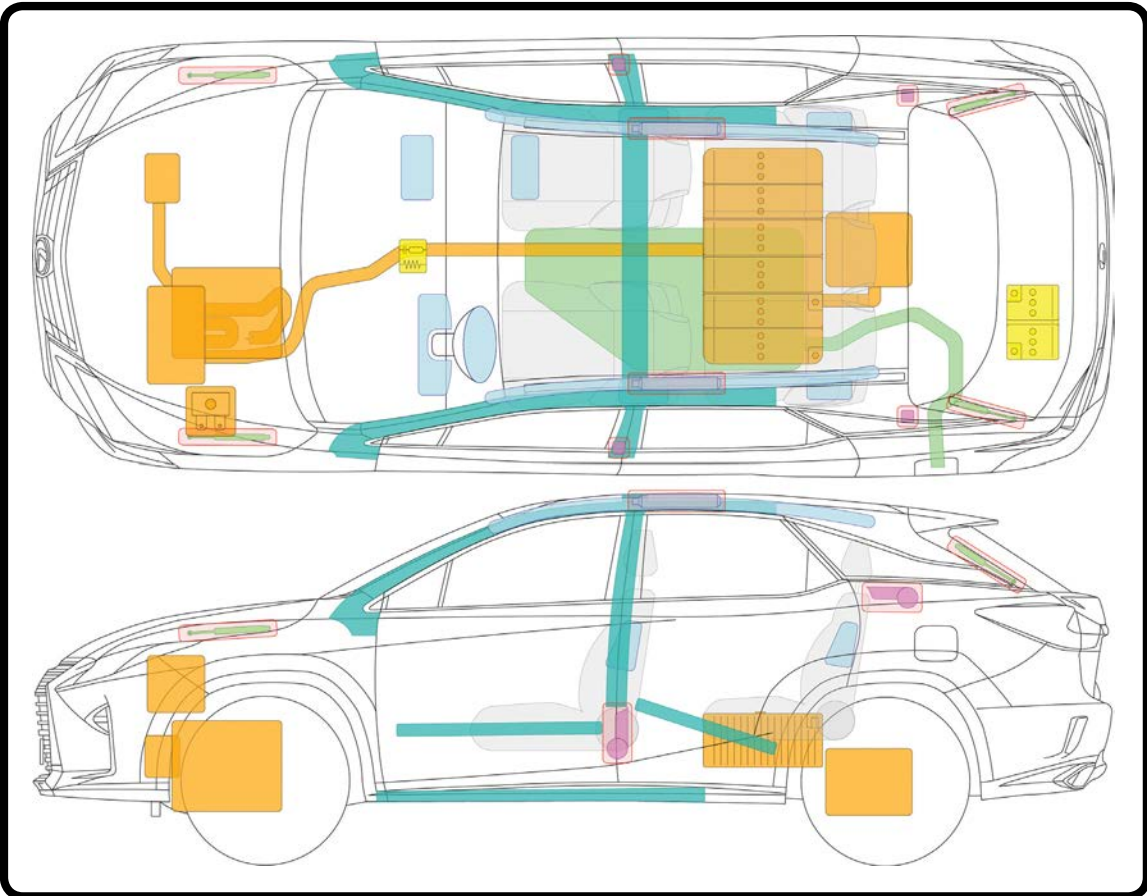

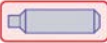

LEXUS RX 450h

(continued) **EXTRICATION INFORMATION**

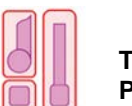

LEGEND

 Airbag	 Bodywork Reinforcements	 SRS Control Unit
 Stored Gas Inflator	 Support Cylinder for Hood	 12V Battery
 Seatbelt Tensioner or Pretensioner	 Fuel Tank	 High-Voltage Power Cable
 High-Voltage Battery	 Emergency Disconnect (Remove Fuse)	

For towing and post-incident instructions, see the **POST-INCIDENT** section on page 20.

LEXUS

LEXUS



2011-12



VEHICLE INFORMATION

IMMOBILIZE VEHICLE

- 1. Chock the wheels.
- 2. Set parking brake. (foot pedal)
- 3. Place vehicle into park. (center console)

DISABLE VEHICLE

Determine if vehicle is ON by illumination of color LCD screens on both sides of speedometer.

PRIMARY PROCEDURE

- 1. If ON, turn the vehicle's ignition off (key on steering column). Remove key.
- 2. Disconnect the negative cable from the 12V battery (engine compartment, driver's side).

ALTERNATE PROCEDURE

- 1. Disconnect the negative cable from the 12V battery.
- 2. Locate the seat backrest latch release levers (2) in the rear storage area between the high-voltage battery and the body sheet metal.
- 3. Push the release lever toward the outboard side of the vehicle.
- 4. Lower rear seat to access disconnect from passenger cabin.
- 5. Remove the high voltage service disconnect.

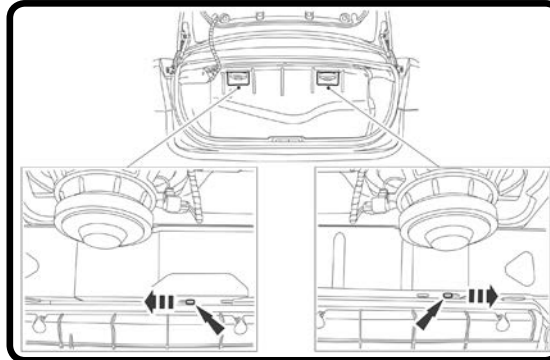



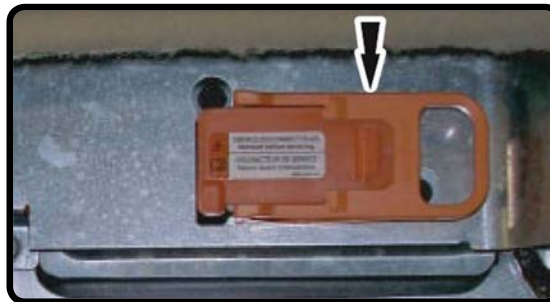

Seat Backrest Latch Releases



High-Voltage Disconnect

WARNINGS

-  NEVER cut, breach, or touch high voltage components or cabling. Doing so could result in serious injury or death.
-  If the vehicle has exposed cables, make sure to wear high-voltage rubber gloves and other protective clothing.
-  If the vehicle is submerged, do not touch high voltage cabling or components until you are SURE the high-voltage battery is fully discharged (when fizzing/bubbling stops).
-  Lack of engine noise does not mean vehicle is OFF. Silent movement or instant restart capability exists until vehicle is fully shut down.

LINCOLN

LINCOLN

MKZ

HEV



2011-12



MKZ

(continued) **EXTRICATION INFORMATION**

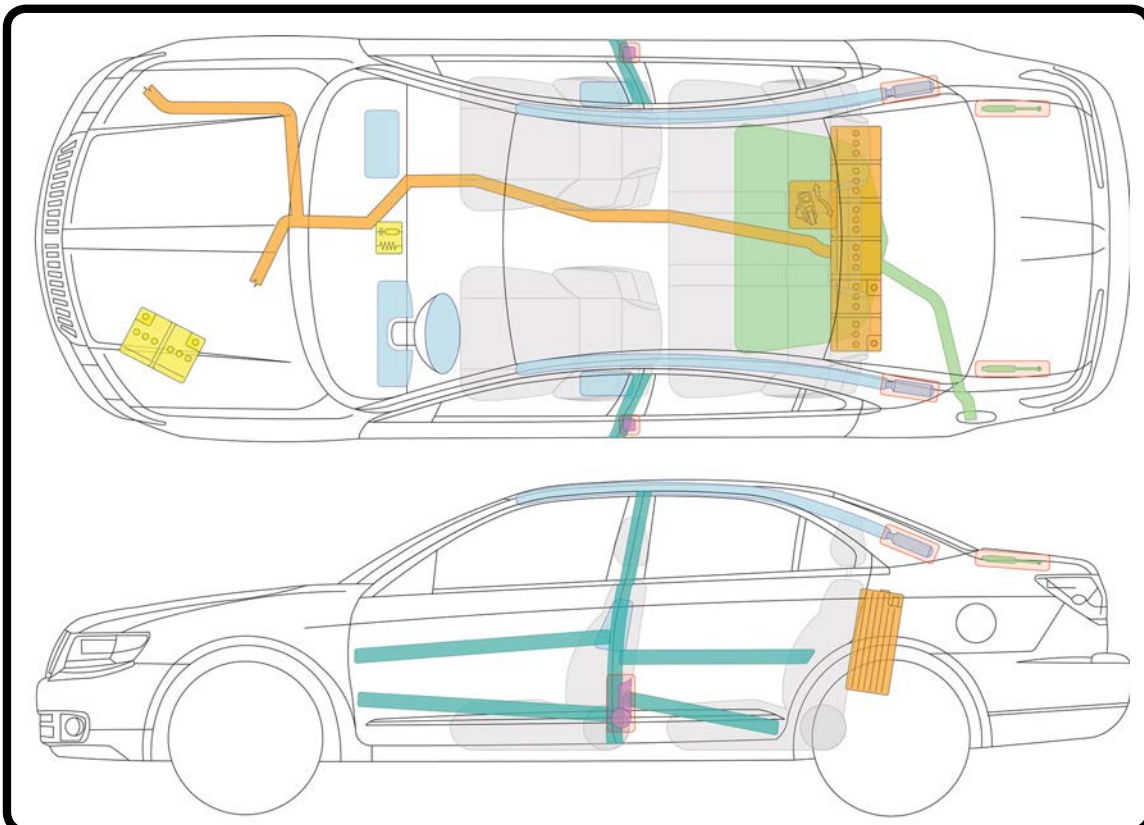

LEGEND		
Airbag	Bodywork Reinforcements	SRS Control Unit
Stored Gas Inflator	Support Cylinder for Hood	12V Battery
Seatbelt Tensioner or Pretensioner	Fuel Tank	High-Voltage Power Cable
High-Voltage Battery	Emergency Disconnect (Remove Plug)	

SUBMERSION

Ford recommends that a submerged vehicle not be removed from water until the high voltage battery is completely discharged (when microbubbling has completely stopped).

For towing and post-incident instructions, see the **POST-INCIDENT** section on page 20.

LINCOLN



2013-18



VEHICLE INFORMATION

Li-ion

See pages 15, 22.

IMMOBILIZE VEHICLE

1. **Chock the wheels.**
2. **Set parking brake.**
(foot pedal)
3. **Place vehicle into park.**
(center console)

DISABLE VEHICLE

Determine if vehicle is ON by illumination of color LCD screens on both sides of speedometer.

PRIMARY PROCEDURE

1. If ON, turn the vehicle's ignition off (Key/Button on dash). Remove key.
2. Disconnect the negative cable from the 12V battery (trunk, driver's side).

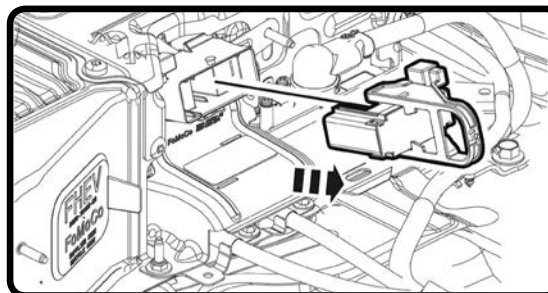

HV Service Disconnect

ALTERNATE PROCEDURE

1. Disconnect the negative cable from the 12V battery (trunk, driver's side).
2. HV service disconnect behind the rear seat back on the driver side. Fold the rear seat back down and remove the cover to access.
3. Pull lever handle outward to disengage interlock. Rotate the lever to horizontal. Remove the HV service disconnect completely.

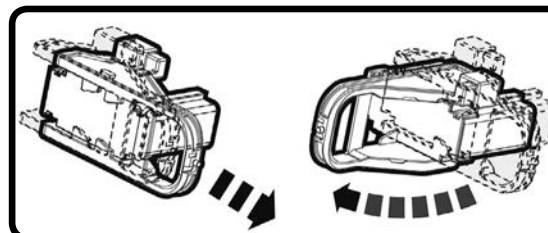



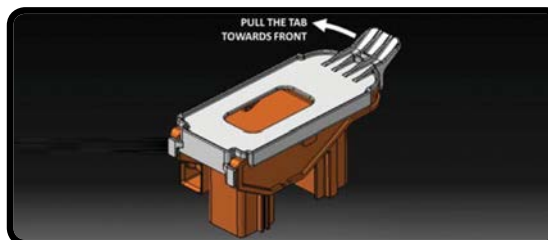

HV Service Disconnect Detail



2014 and Later Year Vehicles Only

WARNINGS

-  NEVER cut, breach, or touch high voltage components or cabling. Doing so could result in serious injury or death.
-  If the vehicle has exposed cables, make sure to wear high-voltage rubber gloves and other protective clothing.
-  If the vehicle is submerged, do not touch high voltage cabling or components until you are SURE the high-voltage battery is fully discharged (when fizzing/bubbling stops).
-  If the vehicle is equipped with remote start, high-voltage may be present in the system if the ignition is off.
-  Lack of engine noise does not mean vehicle is OFF. Silent movement or instant restart capability exists until vehicle is fully shut down.

LINCOLN

LINCOLN

MKZ

HEV



2013-18



MKZ







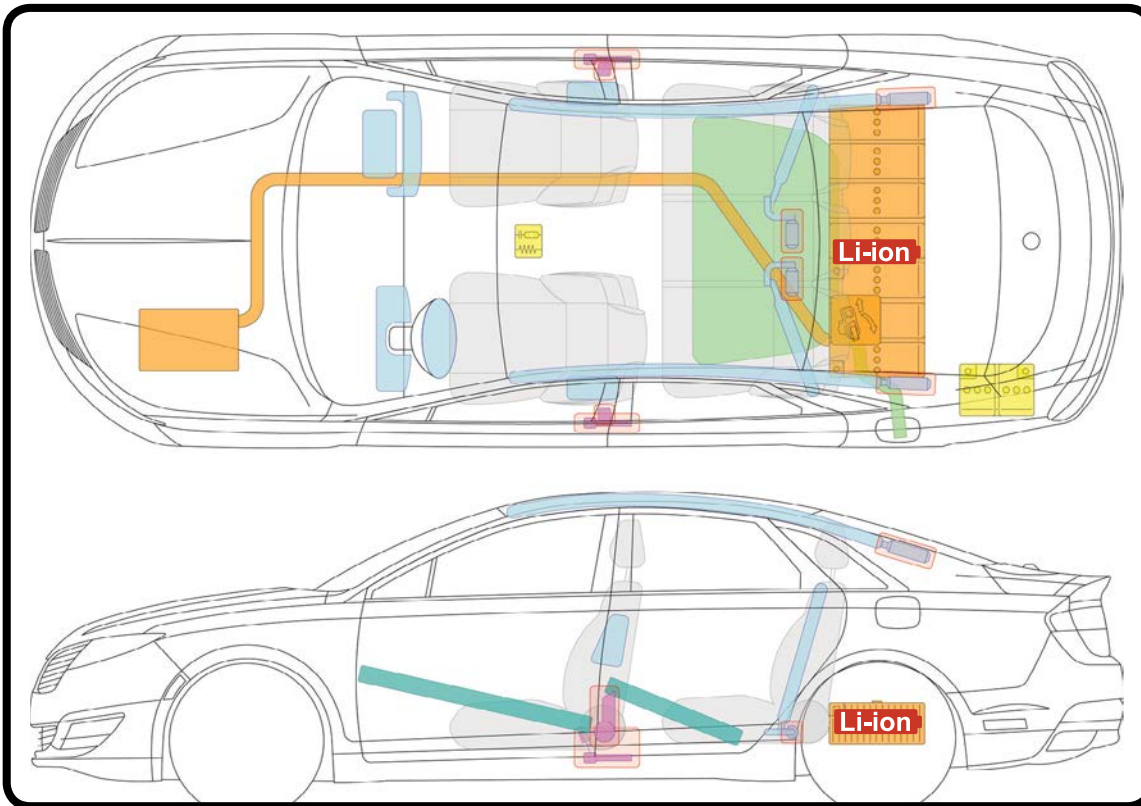

Li-ion (continued)

See pages 15, 22.

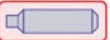
EXTRICATION INFORMATION

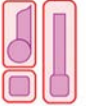

LEGEND

 Airbag	 Bodywork Reinforcements	 SRS Control Unit
 Stored Gas Inflator	 Support Cylinder for Hood	 12V Battery
 Seatbelt Tensioner or Pretensioner	 Fuel Tank	 High-Voltage Power Cable
 High-Voltage Battery	 Emergency Disconnect (Remove Plug)	

SUBMERSION

Ford recommends that a submerged vehicle not be removed from water until the high voltage battery is completely discharged (when microbubbling has completely stopped).

For towing and post-incident instructions, see the **POST-INCIDENT** section on page 20.

LINCOLN

LINCOLN



2008-09



VEHICLE INFORMATION

IMMOBILIZE VEHICLE

- 1. **Chock the wheels.**
- 2. **Set parking brake.**
(foot pedal)
- 3. **Place vehicle into park.**
(center console)

DISABLE VEHICLE

Determine if vehicle is ON by the presence of a small green vehicle icon on the right side of the instrument panel and the tachometer pointing to "EV".

PRIMARY PROCEDURE

- 1. If ON, turn the vehicle's ignition off (key on steering column). Remove key.
- 2. Disconnect the negative cable from the 12V battery (engine compartment, driver's side).

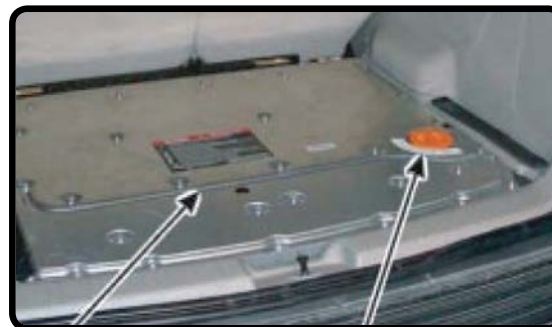

HV Battery Pack

HV Service Disconnect Switch



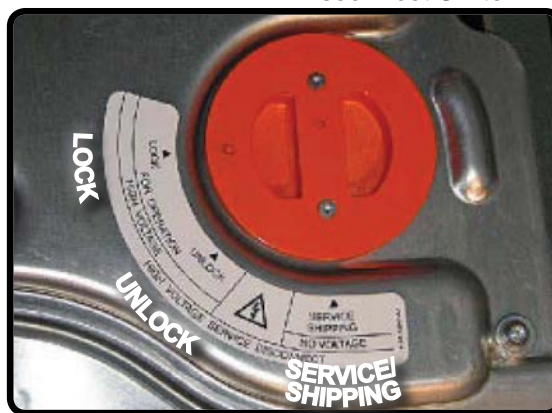

ALTERNATE PROCEDURE

- 1. Disconnect the negative cable from the 12V battery.
- 2. Remove the high voltage service disconnect (located on top of the high-voltage battery in the cargo area) by turning it counterclockwise to the UNLOCK position. Then place the switch in the SERVICE/SHIPPING position.



High-Voltage Service Disconnect Switch Shown in LOCK position

WARNINGS

-  NEVER cut, breach, or touch high voltage components or cabling. Doing so could result in serious injury or death.
-  If neither the ignition nor the 12V battery can be accessed, removing the service disconnect alone will disable the high voltage system, but NOT the airbags.
-  If the vehicle has exposed cables, make sure to wear high-voltage rubber gloves and other protective clothing.
-  If the vehicle is submerged, do not touch high voltage cabling or components until you are SURE the high-voltage battery is fully discharged (when fizzing/bubbling stops).
-  Lack of engine noise does not mean vehicle is OFF. Silent movement or instant restart capability exists until vehicle is fully shut down.

MAZDA

TRIBUTE

MAZDA

HEV



2008-09



HYBRID







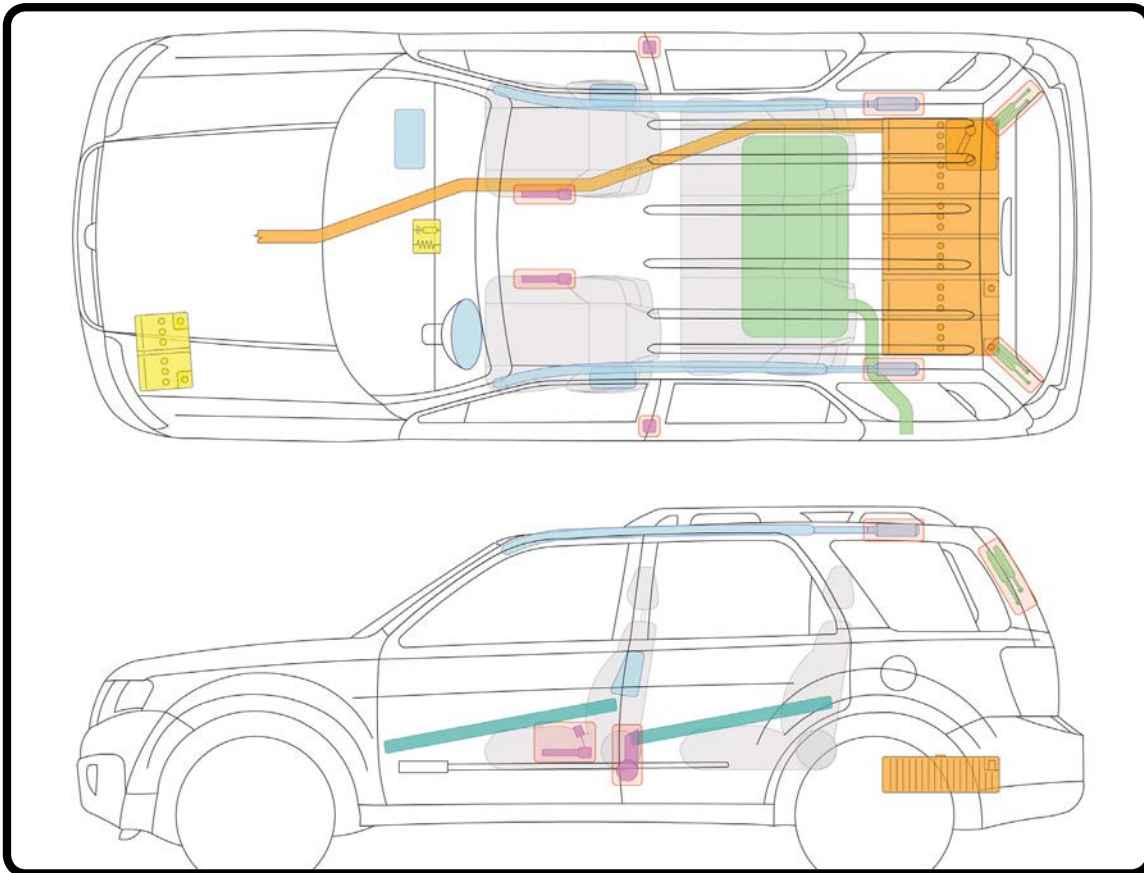

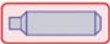

TRIBUTE

(continued) **EXTRICATION INFORMATION**

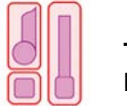

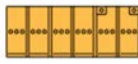
LEGEND

 Airbag	 Bodywork Reinforcements	 SRS Control Unit
 Stored Gas Inflator	 Support Cylinder for Hood	 12V Battery
 Seatbelt Tensioner or Pretensioner	 Fuel Tank	 High-Voltage Power Cable
 High-Voltage Battery	 Emergency Disconnect (Switch Off)	

SUBMERSION

Ford recommends that a submerged vehicle not be removed from water until the high voltage battery is completely discharged (when microbubbling has completely stopped).

For towing and post-incident instructions, see the **POST-INCIDENT** section on page 20.

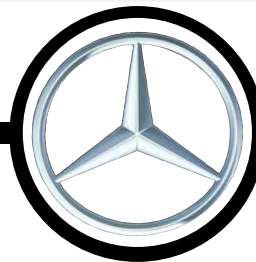

2011-12

MERCEDES-BENZ

Mercedes-Benz

F-CELL

VEHICLE INFORMATION

 See page 24.

IMMOBILIZE VEHICLE

1. **Chock the wheels.**
2. **Set parking brake.** (hand brake, center console)
3. **Place vehicle into park.** (gear selector, center console)

DISABLE VEHICLE

PRIMARY PROCEDURE

1. If ON, turn vehicle ignition key to the OFF position and remove key.
2. Disconnect the 12V battery (on passenger's side of the firewall in the engine compartment).
3. Unplug the HV disconnect (X) (on the top of the refrigerant compressor on the driver's side of the engine compartment). First pull the retaining ring (1) upwards, then unplug the HV disconnect (2).

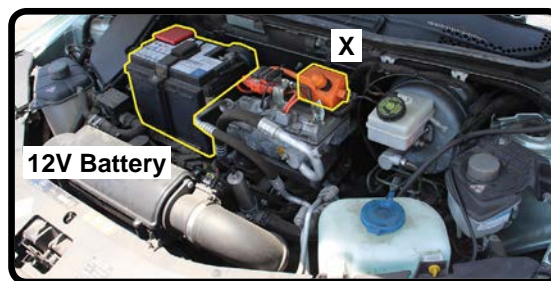

Battery and Service Interruption Location

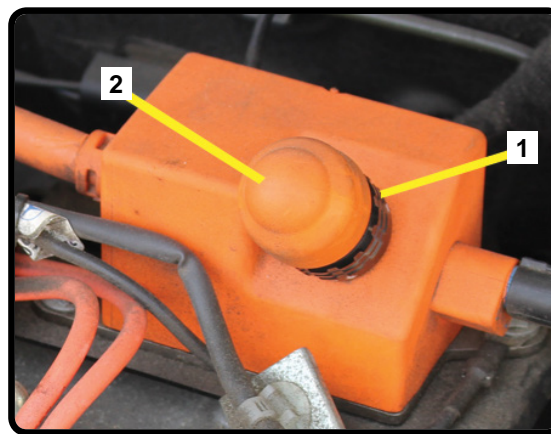

Pull Ring (1) Upwards Then Unplug (2)



SPECIAL CONCERNS

PRESSURE RELIEF VALVE (PRV)

In the event of a malfunction of the hydrogen pressure regulator in the fuel system, the PRV opens and enables the controlled release of the hydrogen via the vent line into the atmosphere. The pressure relief valve opens at pressures above approx. 16 bar. The protective cap on the outlet of the vent line is blown off by the pressure of the escaping hydrogen.

NOTE: Hydrogen gas typically burns with a flame that is only visible at night.

WARNINGS

-  NEVER cut, breach, or touch high voltage components or cabling. Doing so could result in serious injury or death.
-  Do NOT cut the fuel lines, cutting fuel lines will release hydrogen in the fuel lines.
-  Fuel cell vehicles operate silently, lack of an engine noise does not mean the vehicle is OFF. Silent movement capability exists until vehicle is fully shut down.

2011-12

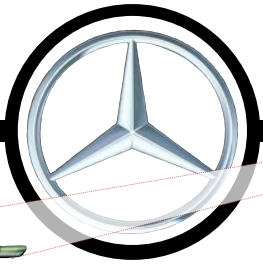

F CELL



See page 24.

(continued)

EXTRICATION INFORMATION

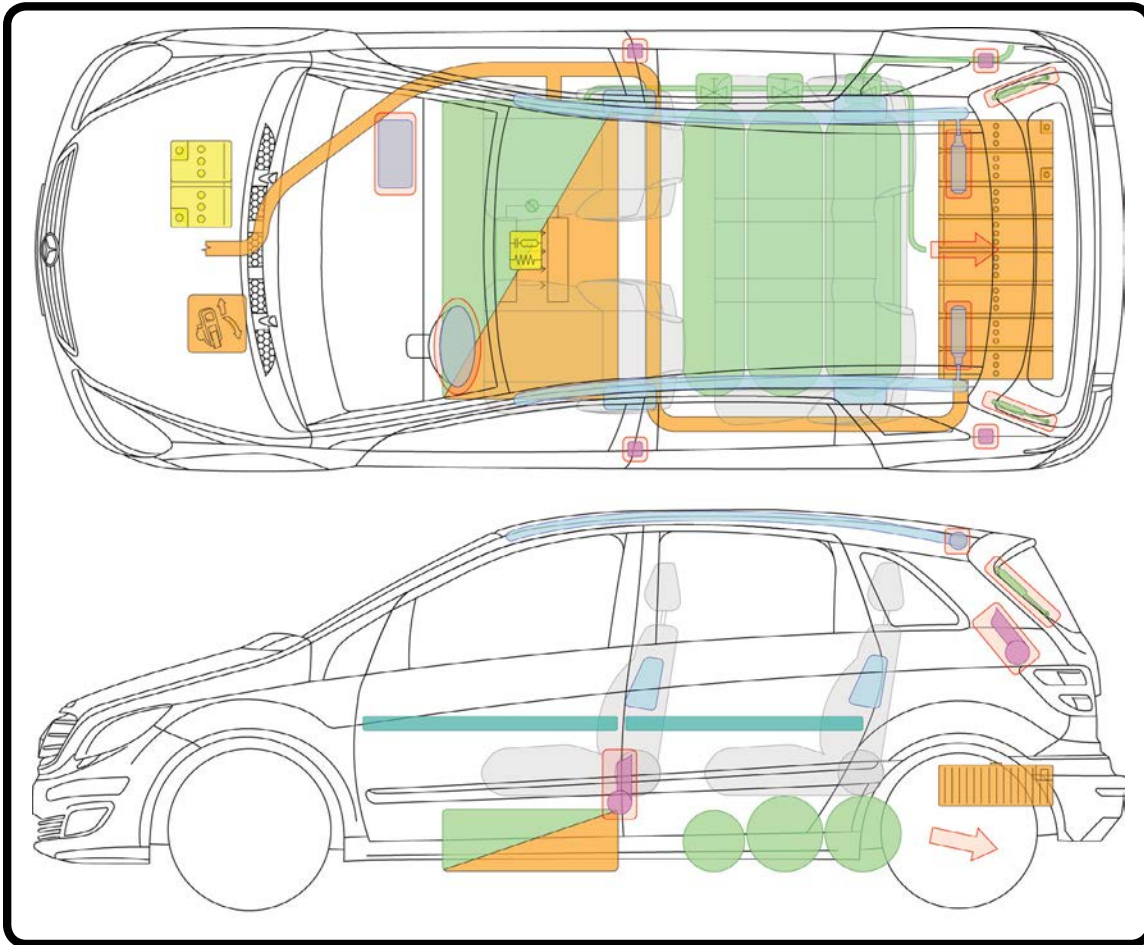

LEGEND		
Airbag	Bodywork Reinforcements	SRS Control Unit
Stored Gas Inflator	Support Cylinder for Hood	12V Battery
Seatbelt Tensioner or Pretensioner	Fuel Tank	High-Voltage Power Cable
High-Voltage Battery	Emergency Disconnect (Remove Plug)	Pressure Relief Valve

For towing and post-incident instructions, see the **POST-INCIDENT** section on page 20.

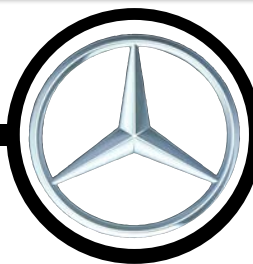

2010-11

Mercedes-Benz

ML 450

VEHICLE INFORMATION

IMMOBILIZE VEHICLE

1. **Chock the wheels.**
2. **Set parking brake.**
(foot pedal)
3. **Place vehicle into park.**
(push-button on steering column gear lever)

DISABLE VEHICLE

PRIMARY PROCEDURE

1. If ON, turn off vehicle ignition (key and/or push-button). Remove key.
2. If possible, disconnect 12V battery (under passenger's seat). If optional 2nd 12V battery is installed, disconnect it as well.
3. If possible, remove proximity key and keep it at least 15 feet (4.5 meters) from vehicle.



ALTERNATE PROCEDURE

Unplug HV Connector (service disconnect) from HV battery (under rear deck lid in trunk).



HV Connector Location

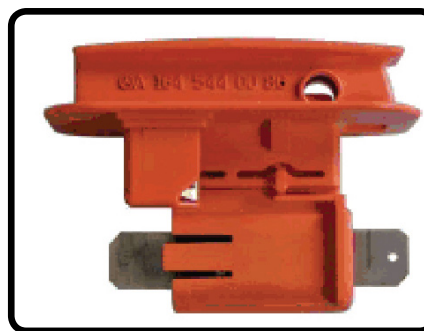

WARNINGS FOR HV DISCONNECT

-  Do not touch HV battery.
-  Insulating gloves must be worn when releasing and disconnecting HV connector on HV battery.
-  Rescue crews should only unplug the HV connector when they have appropriate training or professional qualifications and there are no bare HV cables or bare HV components within 20 centimeters (8 inches) of the HV battery connector.



HV Connector

WARNINGS

-  NEVER cut, breach, or touch high voltage components or cabling. Doing so could result in serious injury or death.
-  Insulating gloves must be worn when unplugging the service disconnect.
-  Lack of engine noise does not mean vehicle is OFF. Silent movement or instant restart capability exists until vehicle is fully shut down.

HEV

MERCEDES-BENZ

ML 450

Mercedes-Benz



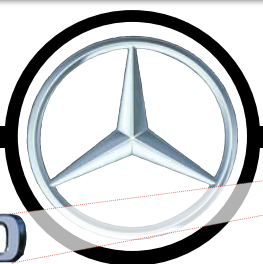





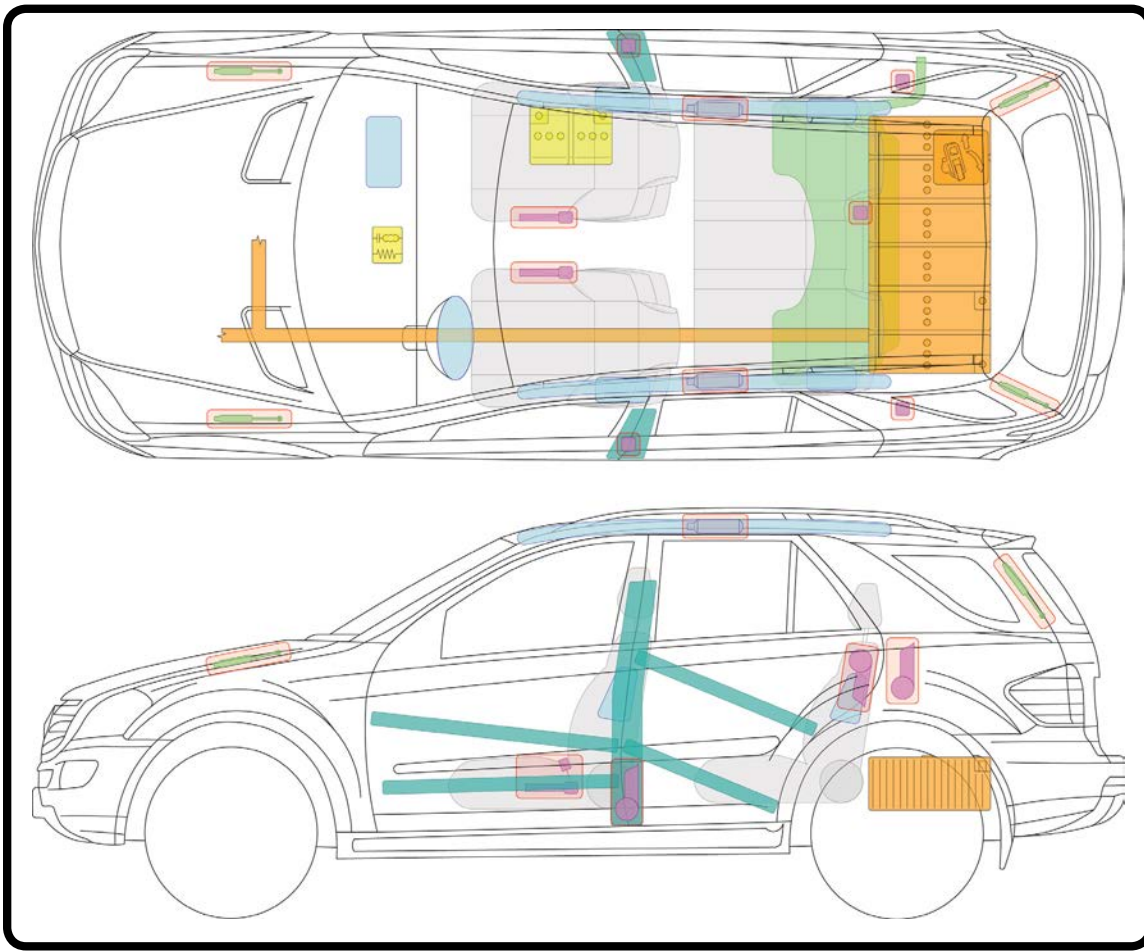

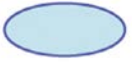
2010-11

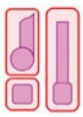

HYBRID

(continued) **EXTRICATION INFORMATION**



LEGEND		
	Airbag	 SRS Control Unit
	Stored Gas Inflator	 12V Battery
	Seatbelt Tensioner or Pretensioner	 High-Voltage Power Cable
	High-Voltage Battery	 Emergency Disconnect (Remove Plug)
	Bodywork Reinforcements	
	Support Cylinder for Hood	
	Fuel Tank	

For towing and post-incident instructions, see the **POST-INCIDENT** section on page 20.

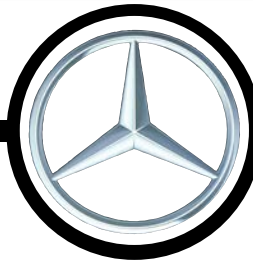

2010-13

Mercedes-Benz

S 400

VEHICLE INFORMATION

IMMOBILIZE VEHICLE

1. **Chock the wheels.**
2. **Set parking brake.**
(push-button, panel left of steering column)
3. **Place vehicle into park.**
(push-button on steering column gear lever)

DISABLE VEHICLE

PRIMARY PROCEDURE

1. If ON, turn off ignition (push-button and/or steering column key). Remove key.
2. Disconnect 12V battery (trunk).
3. If possible, remove key and keep it at least 15 feet (4.5 meters) from vehicle.

ALTERNATE PROCEDURE 1

(if ignition is inaccessible)

1. Unplug low voltage (LV) connector from HV battery (under hood).
2. Disconnect 12V battery (trunk).

ALTERNATE PROCEDURE 2

(if HV battery is deformed)

Unplug HV connector from HV battery (under hood).

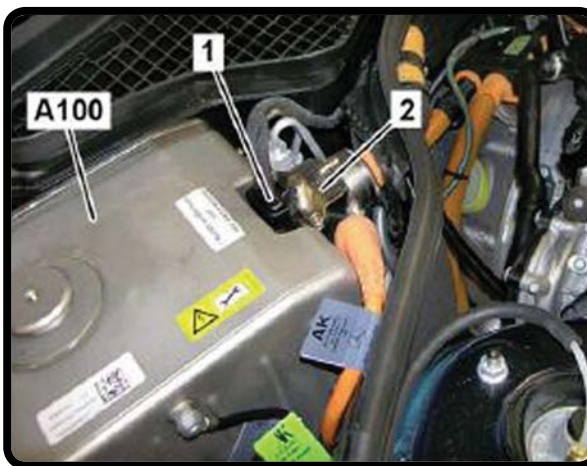

1. LV Connector

2. HV Connector

WARNINGS FOR HV DISCONNECT:

- Do not touch HV battery.
- Insulating gloves must be worn when releasing and disconnecting HV connector on HV battery.
- Rescue crews should only unplug the HV connector when they have appropriate training or professional qualifications and there are no bare HV cables or bare HV components within 20 centimeters (8 inches) of the HV battery connector.

WARNINGS

- NEVER cut, breach, or touch high voltage components or cabling. Doing so could result in serious injury or death.
- Insulating gloves must be worn when unplugging the HV disconnect.
- Lack of engine noise does not mean vehicle is OFF. Silent movement or instant restart capability exists until vehicle is fully shut down.

HEV

MERCEDES-BENZ

S 400

Mercedes-Benz



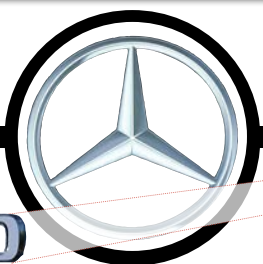



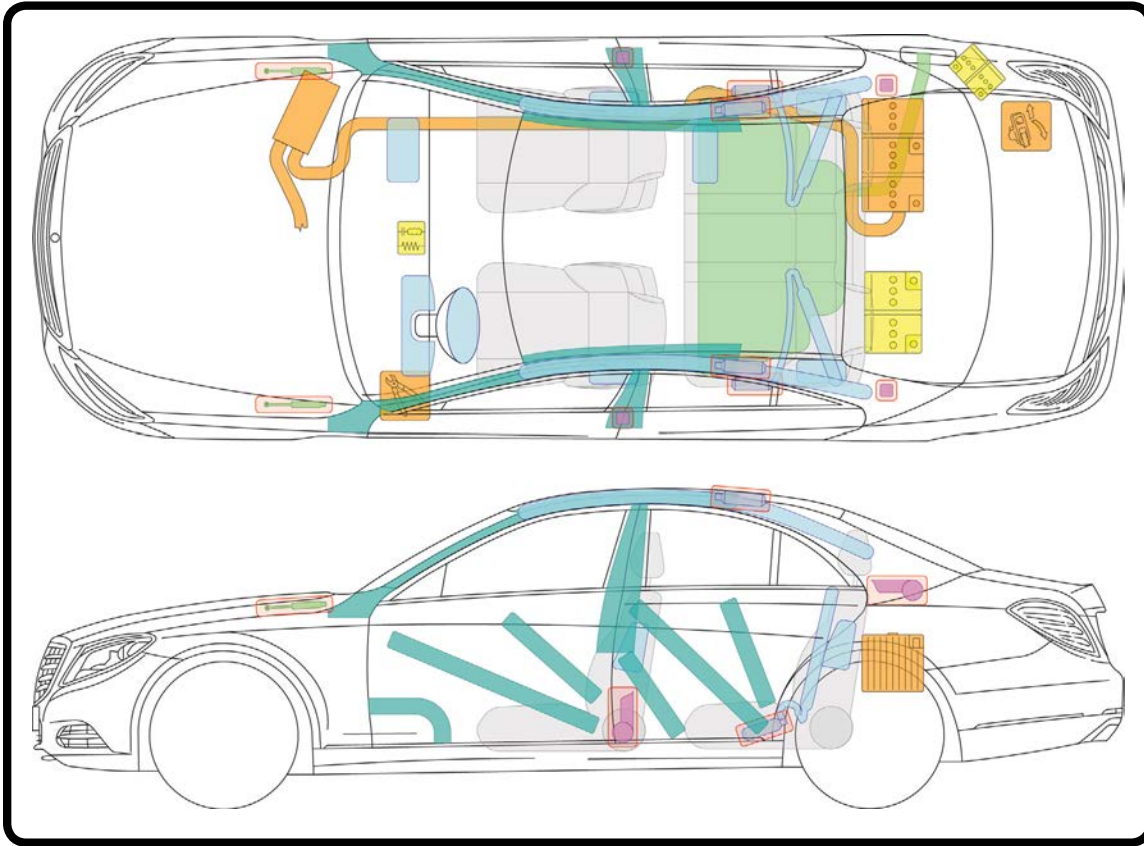

2010-13

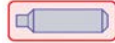

HYBRID

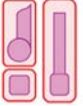
(continued) **EXTRICATION INFORMATION**

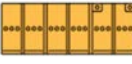

LEGEND		
 Airbag	 Bodywork Reinforcements	 SRS Control Unit
 Stored Gas Inflator	 Support Cylinder for Hood	 12V Battery
 Seatbelt Tensioner or Pretensioner	 Fuel Tank	 High-Voltage Power Cable
 High-Voltage Battery	 Emergency Disconnect (Switch Off)	

For towing and post-incident instructions, see the **POST-INCIDENT** section on page 20.



2006-07



VEHICLE INFORMATION

IMMOBILIZE VEHICLE

1. Chock the wheels.
2. Set parking brake.
(hand brake, center console)
3. Place vehicle into park.
(center console)

DISABLE VEHICLE

Determine if vehicle is ON by the presence of a small green vehicle icon on the right side of the instrument panel. Also, if the tachometer is on the Green EV bar, the vehicle is in its READY mode.

PRIMARY PROCEDURE

1. If ON, turn the vehicle's ignition off (key on steering column). Remove key.
2. Disconnect the negative cable from the 12V battery (engine compartment, driver's side).

ALTERNATE PROCEDURE

1. Disconnect the negative cable from the 12V battery.
2. Remove the high voltage service disconnect (located on top of the high-voltage battery in the cargo area) by turning it counterclockwise to the UNLOCK position. Then place the switch in the SERVICE/SHIPPING position.



HV Battery Pack

HV Service Disconnect Switch

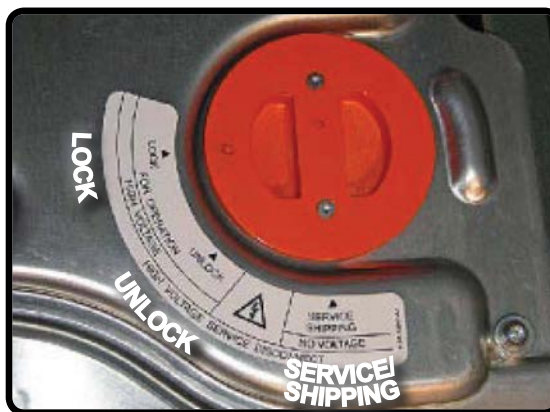

High-Voltage Service Disconnect Switch Shown in LOCK position

WARNINGS

- NEVER cut, breach, or touch high voltage components or cabling. Doing so could result in serious injury or death.
- If the vehicle has exposed cables, make sure to wear high-voltage rubber gloves and other protective clothing.
- If the vehicle is submerged, do not touch high voltage cabling or components until you are SURE the high-voltage battery is fully discharged (when fizzing/bubbling stops).
- Lack of engine noise does not mean vehicle is OFF. Silent movement or instant restart capability exists until vehicle is fully shut down.

MERCURY

MERCURY

MARINER

HEV



2006-07









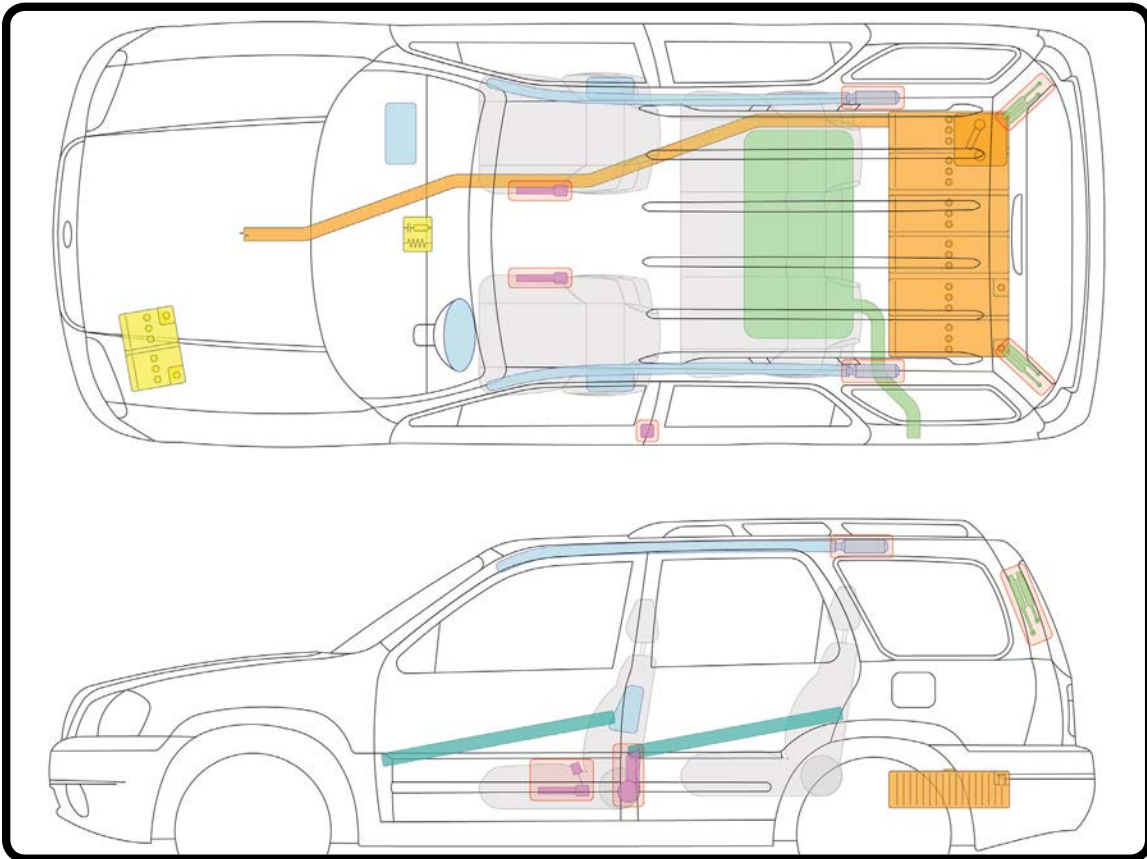

MERCURY

MARINER

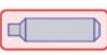
(continued) **EXTRICATION INFORMATION**

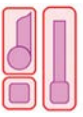

LEGEND

 Airbag	 Bodywork Reinforcements	 SRS Control Unit
 Stored Gas Inflator	 Support Cylinder for Hood	 12V Battery
 Seatbelt Tensioner or Pretensioner	 Fuel Tank	 High-Voltage Power Cable
 High-Voltage Battery	 Emergency Disconnect (Switch Off)	

SUBMERSION

Ford recommends that a submerged vehicle not be removed from water until the high voltage battery is completely discharged (when microbubbling has completely stopped).

For towing and post-incident instructions, see the **POST-INCIDENT** section on page 20.

MERCURY



2008-11



VEHICLE INFORMATION

IMMOBILIZE VEHICLE

- 1. **Chock the wheels.**
- 2. **Set parking brake.**
(foot pedal)
- 3. **Place vehicle into park.**
(center console)

DISABLE VEHICLE

Determine if vehicle is ON by the presence of a small green vehicle icon on the right side of the instrument panel. Also, if the tachometer is on the Green EV bar, the vehicle is in its READY mode.

PRIMARY PROCEDURE

- 1. If ON, turn the vehicle's ignition off (key on steering column). Remove key.
- 2. Disconnect the negative cable from the 12V battery (engine compartment, driver's side).



HV Battery Pack

HV Service Disconnect Switch





ALTERNATE PROCEDURE

- 1. Disconnect the negative cable from the 12V battery.
- 2. Remove the high voltage service disconnect (located on top of the high-voltage battery in the cargo area) by turning it counterclockwise to the UNLOCK position. Then place the switch in the SERVICE/SHIPPING position.



High-Voltage Service Disconnect Switch Shown in LOCK position

WARNINGS

-  NEVER cut, breach, or touch high voltage components or cabling. Doing so could result in serious injury or death.
-  If the vehicle has exposed cables, make sure to wear high-voltage rubber gloves and other protective clothing.
-  If the vehicle is submerged, do not touch high voltage cabling or components until you are SURE the high-voltage battery is fully discharged (when fizzing/bubbling stops).
-  Lack of engine noise does not mean vehicle is OFF. Silent movement or instant restart capability exists until vehicle is fully shut down.

MERCURY

MERCURY

MARINER

HEV



2008-11









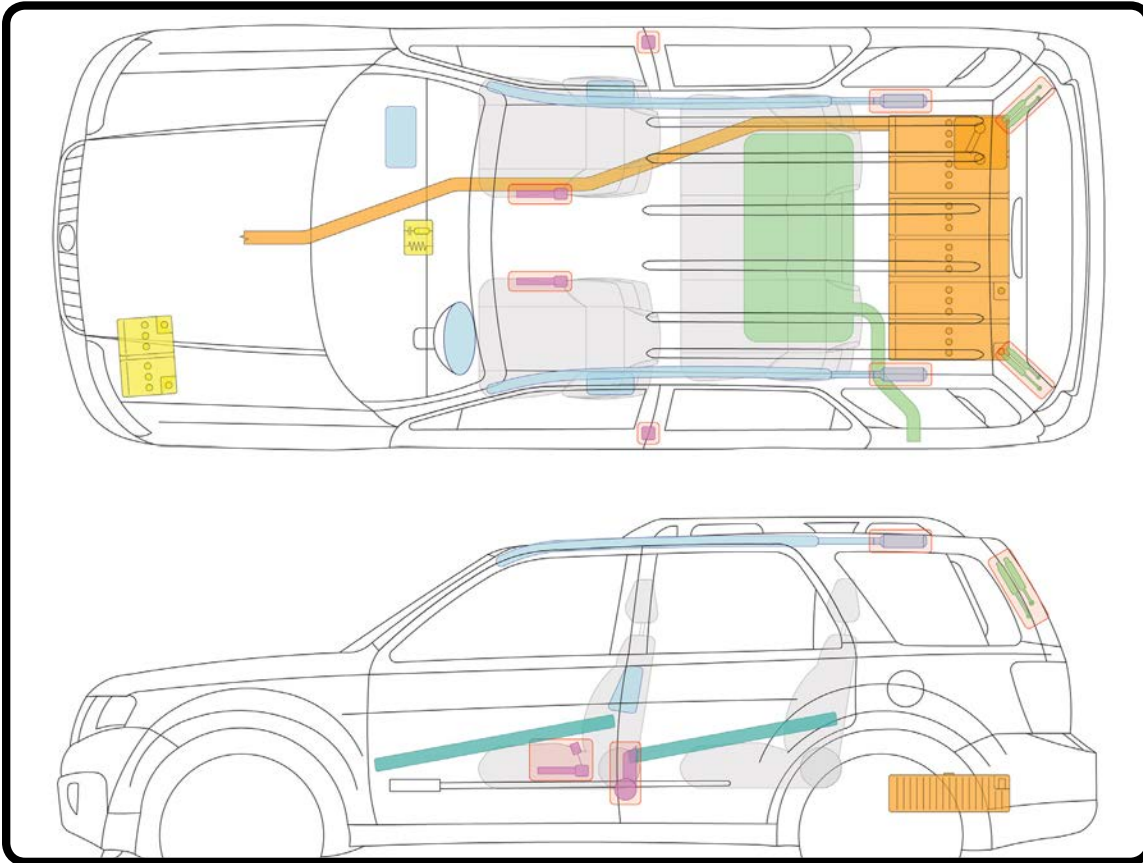



MERCURY

MARINER

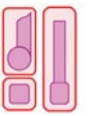
(continued) **EXTRICATION INFORMATION**



LEGEND		
 Airbag	 Bodywork Reinforcements	 SRS Control Unit
 Stored Gas Inflator	 Support Cylinder for Hood	 12V Battery
 Seatbelt Tensioner or Pretensioner	 Fuel Tank	 High-Voltage Power Cable
 High-Voltage Battery	 Emergency Disconnect (Switch Off)	

SUBMERSION

Ford recommends that a submerged vehicle not be removed from water until the high voltage battery is completely discharged (when microbubbling has completely stopped).

For towing and post-incident instructions, see the **POST-INCIDENT** section on page 20.

MERCURY



2010-11



VEHICLE INFORMATION

IMMOBILIZE VEHICLE

1. **Chock the wheels.**
2. **Set parking brake.**
(foot pedal)
3. **Place vehicle into park.**
(center console)

DISABLE VEHICLE

Determine if vehicle is ON by illumination of color LCD screens on both sides of speedometer.

PRIMARY PROCEDURE

1. If ON, turn the vehicle's ignition off (key on steering column). Remove key.
2. Disconnect the negative cable from the 12V battery (engine compartment, driver's side).

ALTERNATE PROCEDURE

1. Disconnect the negative cable from the 12V battery.
2. Locate the seat backrest latch release levers (2) in the rear storage area between the high-voltage battery and the body sheet metal.
3. Push the release lever toward the outboard side of the vehicle.
4. Lower rear seat to access disconnect from passenger cabin.
5. Remove the high voltage service disconnect.

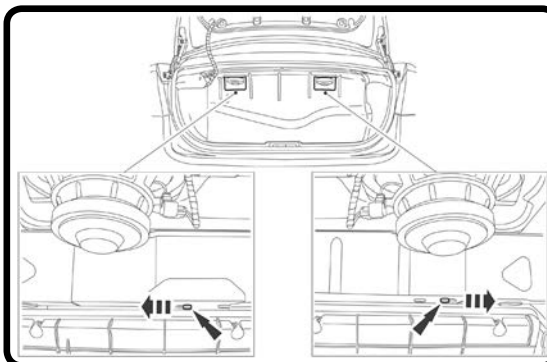





Seat Backrest Latch Releases



High-Voltage Disconnect

WARNINGS

-  NEVER cut, breach, or touch high voltage components or cabling. Doing so could result in serious injury or death.
-  If the vehicle has exposed cables, make sure to wear high-voltage rubber gloves and other protective clothing.
-  If the vehicle is submerged, do not touch high voltage cabling or components until you are SURE the high-voltage battery is fully discharged (when fizzing/bubbling stops).
-  Lack of engine noise does not mean vehicle is OFF. Silent movement or instant restart capability exists until vehicle is fully shut down.

MERCURY

MERCURY

MILAN

HEV



2010-11









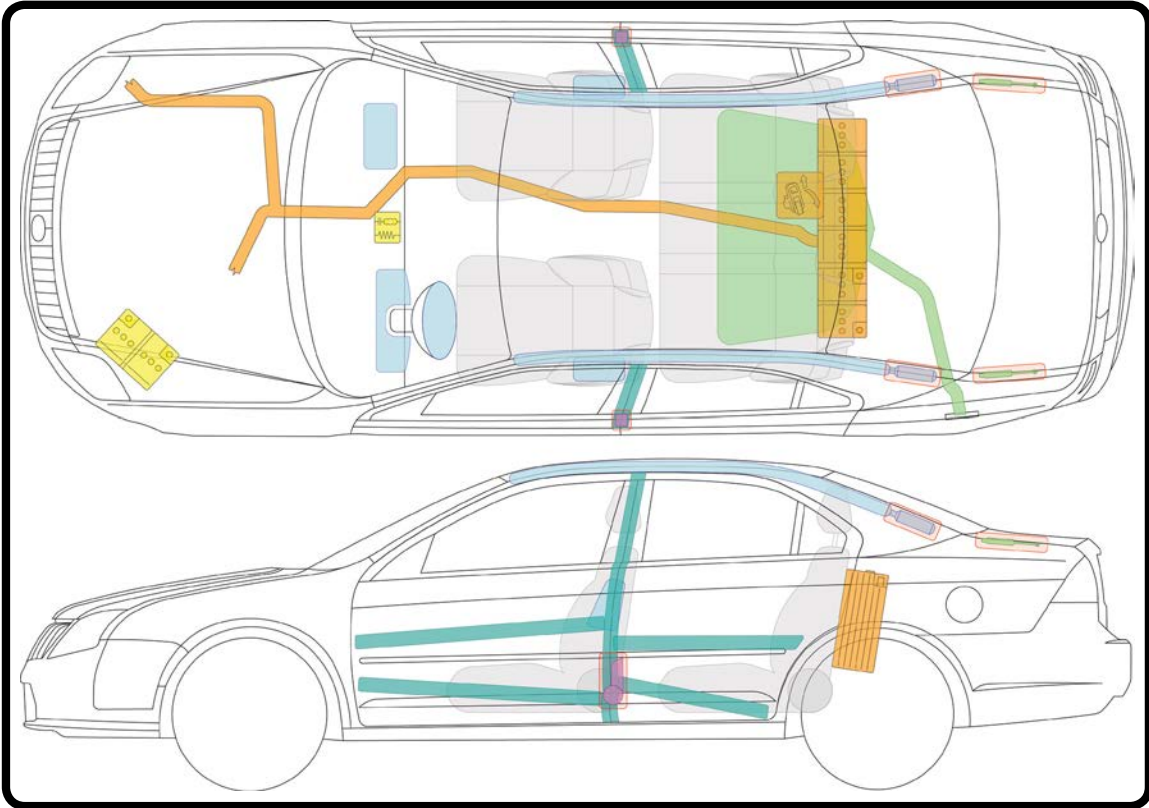

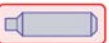

MERCURY

MILAN

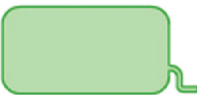
(continued) **EXTRICATION INFORMATION**

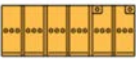

LEGEND		
 Airbag	 Bodywork Reinforcements	 SRS Control Unit
 Stored Gas Inflator	 Support Cylinder for Hood	 12V Battery
 Seatbelt Tensioner or Pretensioner	 Fuel Tank	 High-Voltage Power Cable
 High-Voltage Battery	 Emergency Disconnect (Remove Plug)	

SUBMERSION

Ford recommends that a submerged vehicle not be removed from water until the high voltage battery is completely discharged (when microbubbling has completely stopped).

For towing and post-incident instructions, see the **POST-INCIDENT** section on page 20.

MERCURY



2017-18



VEHICLE INFORMATION

Li-ion

See pages 15, 22.

IMMOBILIZE VEHICLE

1. **Chock the wheels.**
2. **Set parking brake.**
(pull the "P" switch, center console)
3. **Place vehicle into park.**
(gear selector, center console)

DISABLE VEHICLE

Determine if vehicle is ON by presence of READY indicator near the tachometer.

PRIMARY PROCEDURE

1. If ON, turn the vehicle's ignition off by pressing the Start/Stop button.
2. Remove proximity key and keep it at least 16 feet from the vehicle.
3. Disconnect the 12V negative battery cable (underneath battery cover in the engine compartment).
4. Disconnect the (1) connector lock (red) and pull apart (2) high voltage connection (right side trim panel in trunk). The connector and socket cannot be pulled apart entirely.



12V Battery Disconnect

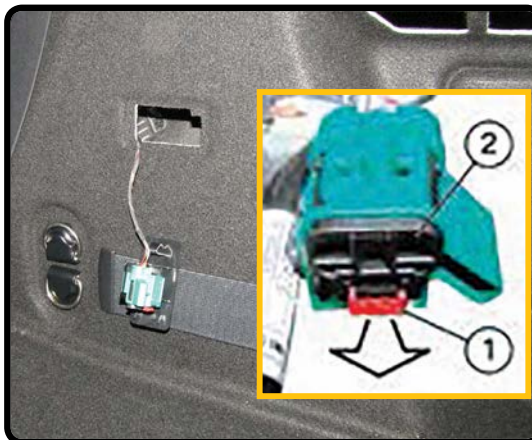

HV Connector Lock





HV Disconnect Cable

ALTERNATE PROCEDURE

(if trunk disconnect is not accessible)

1. Cut the high voltage disconnect cable in the engine compartment.
2. Disconnect the 12V negative battery cable (underneath battery cover in the engine compartment).

WARNINGS

-  NEVER cut, breach, or touch high voltage components or cabling (orange coating). Doing so could result in serious injury or death.
-  Even after the high-voltage system has been switched off, there may still be residual voltage. This will dissipate, however, in a few seconds.
-  Lack of engine noise does not mean vehicle is OFF. Silent movement capability exists until vehicle is fully shut down.

MINI

MINI

COOPERS



2017-18



COOPER S

Li-ion (continued) **EXTRICATION INFORMATION**

See pages 15, 22.

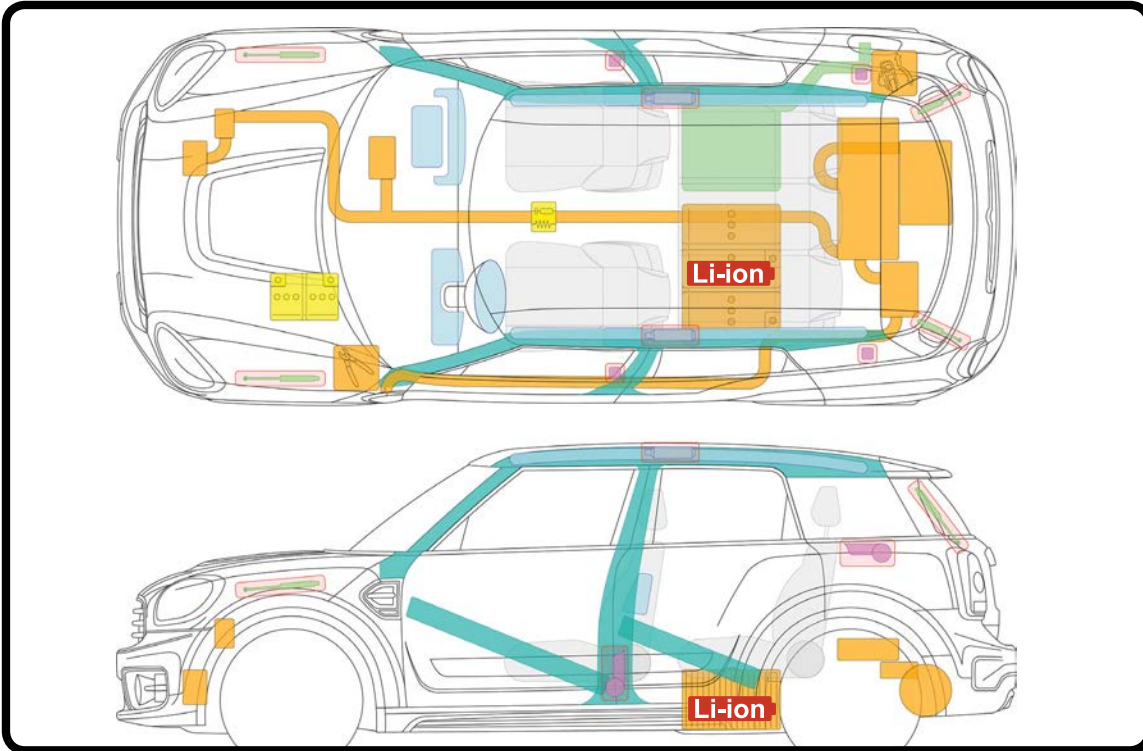

LEGEND		
	Airbag	
	Stored Gas Inflator	
	Seatbelt Tensioner or Pretensioner	
	High-Voltage Battery	
	Bodywork Reinforcements	
	Support Cylinder for Hood	

A PLUGGED IN VEHICLE

If the vehicle is plugged in for charging, you should first unplug it. If access to unplug the vehicle is unavailable, “remove charge power” from the vehicle (done by turning off the power to the charge station).

For towing and post-incident instructions, see the **POST-INCIDENT** section on page 20.



Vehicle Charging Plug

MINI



2012-17

i MiEV

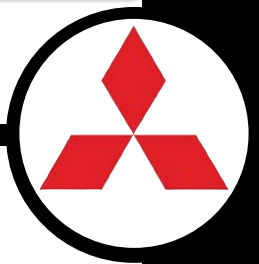

VEHICLE INFORMATION

Li-ion

See pages 15, 22.

IMMOBILIZE VEHICLE

1. **Chock the wheels.**
2. **Set parking brake.**
(hand brake, center console)
3. **Place vehicle into park.**
(lever, center console)

DISABLE VEHICLE

NOTE: Mitsubishi strongly recommends first responders use insulated electrical PPE (400V gloves and rubber soled insulating shoes) for all response situations.

Determine if vehicle is ON by presence of READY indicator.

PRIMARY PROCEDURE

(if extrication is not necessary)

1. If ON, turn off ignition (key, steering column).
2. Wait 1 minute.
3. Disconnect negative 12V battery cable (under hood—hood release is under the instrument panel beside the **front passenger's door**).



Hood Release Latch

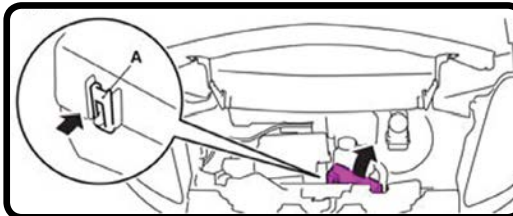

Fuse Box Location

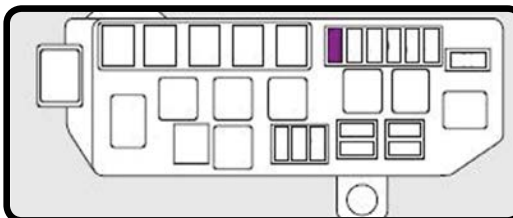

Fuse No. 7 Location

ALTERNATE PROCEDURE 1

(if ignition is not accessible)

1. Open hood, remove fuse box cover (hood release is under the instrument panel beside the **front passenger's door**).
2. Remove No. 7 15A fuse shown in figure. If the correct fuse cannot be identified, remove all fuses and relays in fuse box.
3. Wait 1 minute.
4. Disconnect negative 12V battery cable (under hood).
5. Wait 5 minutes for capacitors to drain down before beginning extrication.

ALTERNATE PROCEDURE 2 (if ignition is not accessible, and electrical PPE is available)

1. Follow Alternate Procedure 1 steps 1–5.
2. Remove service plug (under driver's seat—see diagram on next page).

WARNINGS (continued on the next page)



NEVER cut, breach, or touch high voltage components or cabling. Doing so could result in serious injury or death. Do not touch damaged or exposed HV components without insulated electrical PPE (400V gloves minimum).

MITSUBISHI

MITSUBISHI

i MiEV



2012-17

i MiEV



i MiEV

Li-ion (continued) **EXTRICATION INFORMATION**

See pages 15, 22.

WARNINGS (continued)

- Do not remove service plug without insulated electrical PPE.
- The high voltage system may remain powered for up to 1 minutes after the vehicle is shut off.
- Wait 5 minute for complete discharge of the airbag capacitor after the battery cable has been disconnected.
- In the event of a fire involving a charging station, reference the **FIRE** portion of this guide, and treat it as an energized electrical fire until power to the charger can be shut down.
- This vehicle does not have an internal combustion engine. Lack of engine noise does not mean vehicle is OFF. Silent movement capability exists until vehicle is fully shut down.

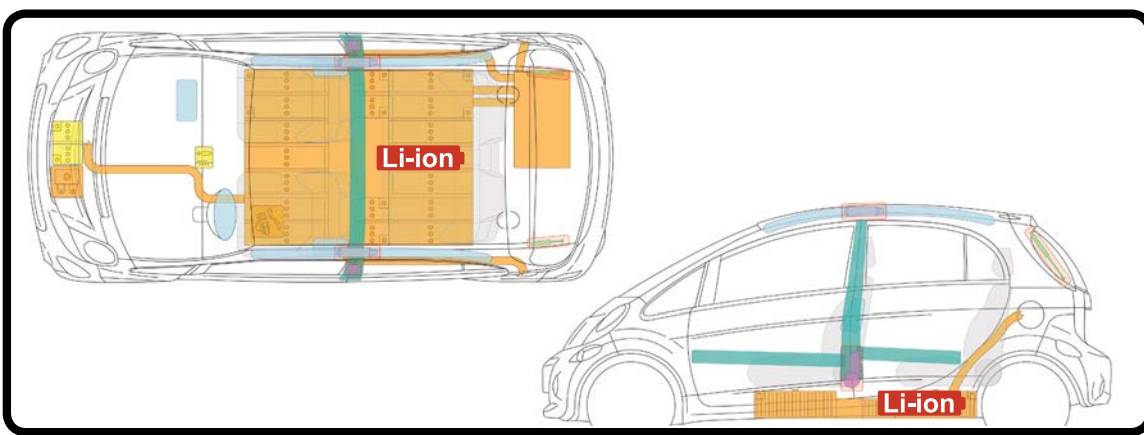

Airbag	Bodywork Reinforcements	SRS Control Unit
Stored Gas Inflator	Support Cylinder for Hood	12V Battery
Seatbelt Tensioner or Pretensioner		High-Voltage Power Cable
High-Voltage Battery	Emergency Disconnect (Remove Fuse)	Emergency Disconnect (Remove Plug)

SUBMERSION

After removing the vehicle from water, flush the high voltage battery by the following procedure: Remove the service lid (under front left seat) while wearing insulating PPE (400V minimum resistance gloves), and pour at least 8 gallons (30 liters) of non-saline water into the service lid hole.

For towing and post-incident instructions, see the **POST-INCIDENT** section on page 20.

MITSUBISHI

MITSUBISHI



2018

PLUG-IN HYBRID
EV

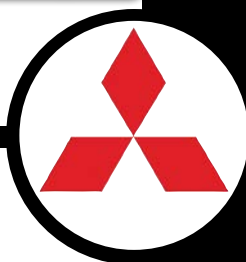

VEHICLE INFORMATION

Li-ion

See pages 15, 22.

IMMOBILIZE VEHICLE

1. **Chock the wheels.**
2. **Set parking brake.**
(electric switch, center console)
3. **Place vehicle into park.**
(electric button on center console)

DISABLE VEHICLE

Determine if vehicle is ON by presence of READY indicator.

PRIMARY PROCEDURE

1. If ON, turn off ignition (push-button, right of steering column).
2. If possible, locate and remove proximity key and keep at least 6 feet away from vehicle.
3. Disconnect negative cable from 12V battery (trunk, left side).



12V Battery Negative Cable In Trunk

ALTERNATE PROCEDURE 1

(if ignition is not accessible)

1. Open hood, remove fuse box cover.
2. Remove Terminal F7, 10A fuse (red) shown in figure. If the correct fuse cannot be identified, remove all fuses and relays in fuse box.
3. Disconnect negative cable from 12V battery (trunk, left side).

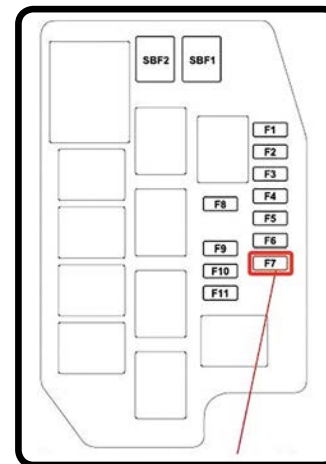

F7 Fuse Location

WARNINGS

- NEVER cut, breach, or touch high voltage components or cabling. Doing so could result in serious injury or death.
- Do not remove service plug without insulated electrical PPE.
- The high voltage system may remain powered for up to 10 minutes after the vehicle is shut off.
- Wait 5 minute for complete discharge of the airbag capacitor after the battery cable has been disconnected.
- Lack of engine noise does not mean vehicle is OFF. Silent movement or instant restart capability exists until vehicle is fully shut down.

MITSUBISHI

MITSUBISHI

OUTLANDER



2018

PHEV









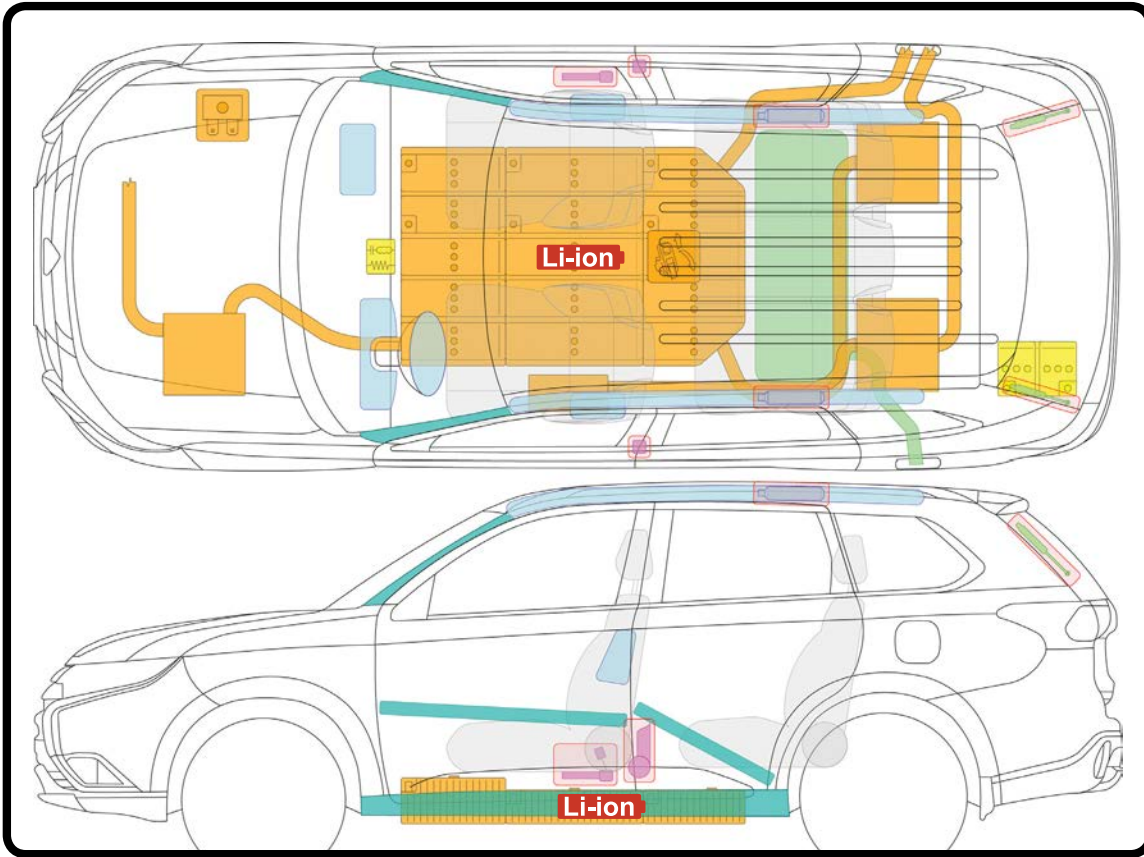

OUTLANDER

Li-ion (continued) **EXTRICATION INFORMATION**

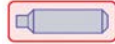
See pages 15, 22.

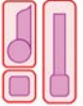

LEGEND

 Airbag	 Bodywork Reinforcements	 SRS Control Unit
 Stored Gas Inflator	 Support Cylinder for Hood	 12V Battery
 Seatbelt Tensioner or Pretensioner		 High-Voltage Power Cable
 High-Voltage Battery	 Emergency Disconnect (Remove Fuse)	 Emergency Disconnect (Remove Plug)

For towing and post-incident instructions, see the **POST-INCIDENT** section on page 20.



2007-11

HYBRID



NISSAN

NISSAN

ALTIMA

VEHICLE INFORMATION

IMMOBILIZE VEHICLE

- 1. Chock the wheels.
- 2. Set parking brake. (foot pedal)
- 3. Place vehicle into park. (center console)

DISABLE VEHICLE

Verify if vehicle is ON by presence of green READY light in the instrument cluster. READY

PRIMARY PROCEDURE

- 1. If ON, turn off ignition (push-button, right of steering column).
- 2. If possible, locate and remove proximity key and keep at least 3.25 feet (1 meter) away from vehicle.
- 3. Disconnect negative cable from 12V battery (trunk, right side).

ALTERNATE PROCEDURE 1

- 1. Disconnect negative cable from 12V battery (trunk, right side).
- 2. Locate underhood fuse box (driver's side) and remove cover.
- 3. Remove IGCT 50A relay. If correct fuse cannot be identified, pull all fuses in fuse box.

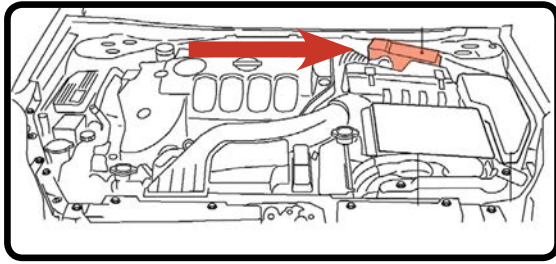

Fuse Box Location

ALTERNATE PROCEDURE 2

(if ignition is not accessible)

- 1. Disconnect both positive and negative cables from 12V battery (trunk, right side).
- 2. Remove service disconnect from HV battery (requires electrical PPE). Location is indicated on next page. Access HV switch in trunk, front right side.

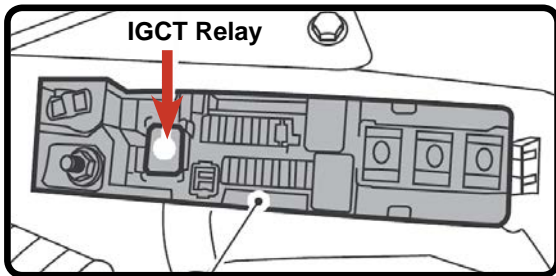

High Voltage Fuse and Fusible Link Box

WARNINGS (continued on the next page)

- NEVER cut, breach, or touch orange high voltage components or cabling. Doing so could result in serious injury or death.
- The high voltage system may remain powered for up to 10 minutes after the vehicle is disabled. The HV system will be below 60V after 5 minutes.
- SRS may remain powered for up to 3 minutes after vehicle is disabled.
- Removal of service plug requires use of electrical PPE (insulated gloves, shoes, and face shield)
- High voltage cables on the underside of the vehicle are encased in a black plastic protector, hiding them from sight.

HEV



2007-11

HYBRID



ALTIMA

NISSAN

(continued) **EXTRICATION INFORMATION**

WARNINGS (continued)

Lack of engine noise does not mean vehicle is OFF. Silent movement or instant restart capability exists until vehicle is fully shut down.

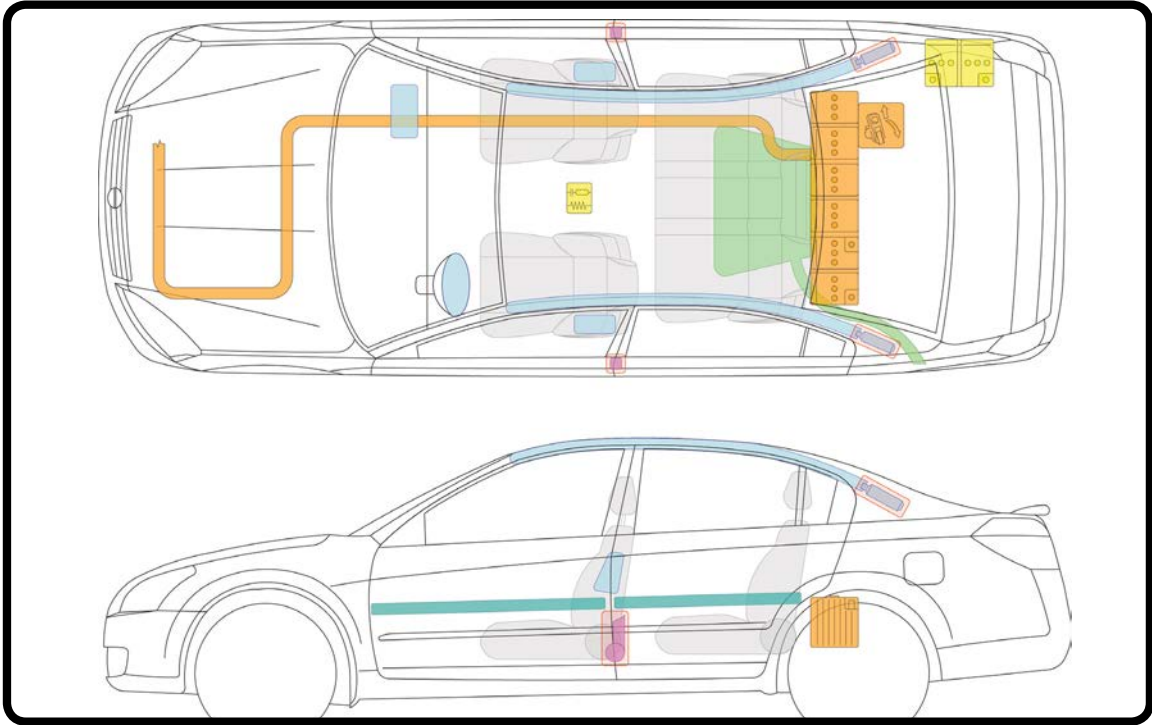

LEGEND		
Airbag	Bodywork Reinforcements	SRS Control Unit
Stored Gas Inflator	Support Cylinder for Hood	12V Battery
Seatbelt Tensioner or Pretensioner	Fuel Tank	High-Voltage Power Cable
High-Voltage Battery	Emergency Disconnect (Remove Plug)	

STORAGE

The service disconnect should be removed prior to vehicle storage.

For towing and post-incident instructions, see the **POST-INCIDENT** section on page 20.



2011-12

Zero Emission



VEHICLE INFORMATION

Li-ion
See pages 15, 22.

IMMOBILIZE VEHICLE

1. **Chock the wheels.**
2. **Set parking brake.**
(pull up on push/pull switch, center console)
3. **Place vehicle into park.**
(push P in joystick, center console)

DISABLE VEHICLE

Determine if the vehicle is ON by presence of READY indicator:

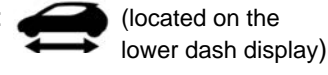

PRIMARY PROCEDURE

1. If ON, turn off vehicle by pressing power button.
2. Verify READY indicator is OFF.
3. If possible, keep proximity key at least 16 feet (5 meters) away from vehicle.
4. Disconnect negative 12V battery cable (under hood).

ALTERNATE PROCEDURE 1

1. Open under-hood fuse box (may be difficult to access).
2. Remove fuses F3, F15, F21. If correct fuse cannot be identified, pull all fuses in fuse box.
3. Disconnect negative 12V battery cable (under hood).

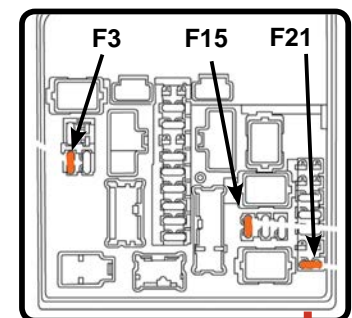

Fuse Box

ALTERNATE PROCEDURE 2

1. Locate and lift the carpet flap behind the center console.
2. Remove access cover bolts and cover (10 mm hex bolts).
3. Remove the service plug by pressing the locking tab (1) and rotating the handle (2) upward. Using the handle, pull service plug completely out of socket.
4. Disconnect negative 12V battery cable (under hood).

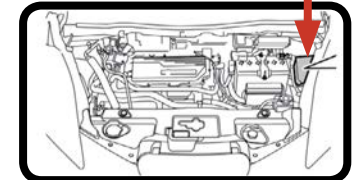

Fuse Box Location

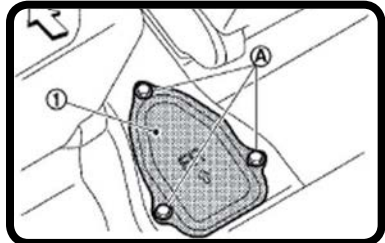

Disconnect Cover

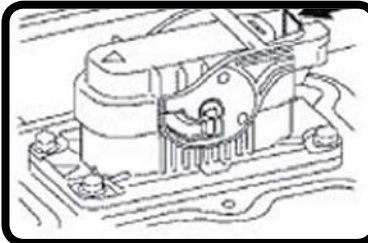

Remove Service Plug 1

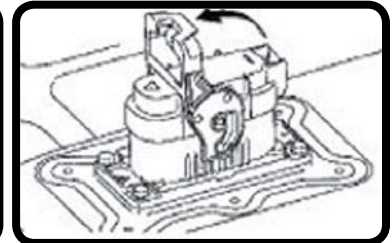

Remove Service Plug 2

WARNINGS (continued on the next page)

- NEVER cut, breach, or touch orange high voltage components or cabling. Doing so could result in serious injury or death.
- The high voltage system may remain powered for up to 10 minutes after the vehicle is disabled. The HV system will be below 60V after 5 minutes.
- SRS may remain powered for up to 3 minutes after vehicle is disabled.

NISSAN LEAF

NISSAN

EV



2011-12

Zero Emission



LEAF

NISSAN

Li-ion (continued) **EXTRICATION INFORMATION**

See pages 15, 22.

WARNINGS (continued)

- Removal of service plug requires the use of electrical PPE (insulated gloves, shoes, and face shield).
- In the event of a fire involving a charging station, reference the **FIRE** portion of this guide, and treat it as an energized electrical fire until power to the charger can be shut down.
- This vehicle does not have an internal combustion engine. Lack of engine noise does not mean vehicle is OFF. Silent movement capability exists until vehicle is fully shut down.

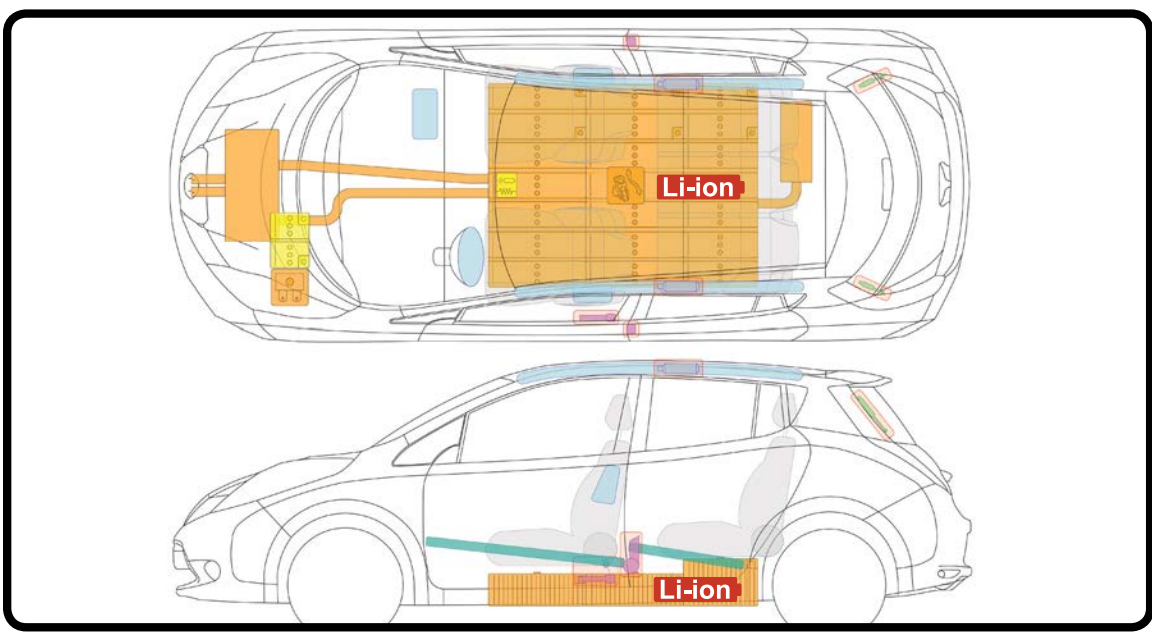

LEGEND			
Airbag	Bodywork Reinforcements	SRS Control Unit	
Stored Gas Inflator	Support Cylinder for Hood	12V Battery	
Seatbelt Tensioner or Pretensioner		High-Voltage Power Cable	
High-Voltage Battery	Emergency Disconnect (Remove Fuse)	Emergency Disconnect (Remove Plug)	

STORAGE

The service disconnect should be removed prior to vehicle storage.

For towing and post-incident instructions, see the **POST-INCIDENT** section on page 20.



2013-17

Zero Emission



VEHICLE INFORMATION

Li-ion

See pages 15, 22.

IMMOBILIZE VEHICLE

1. **Chock the wheels.**
2. **Set parking brake.**
(pull up on push/pull switch, center console)
3. **Place vehicle into park.**
(push P in joystick, center console)

DISABLE VEHICLE

Determine if the vehicle is ON by presence of READY indicator:  (located on the lower dash display)

PRIMARY PROCEDURE

1. If ON, turn off vehicle by pressing power button.
2. Verify READY indicator is OFF.
3. If possible, keep proximity key at least 16 feet (5 meters) away from vehicle.
4. Disconnect negative 12V battery cable (under hood).

ALTERNATE PROCEDURE 1

1. Open both under-hood fuse boxes.
2. Remove fuses F24, F3 and 20A VCM (yellow). If correct fuse cannot be identified, pull all fuses in fuse box.
3. Disconnect negative 12V battery cable (under hood).

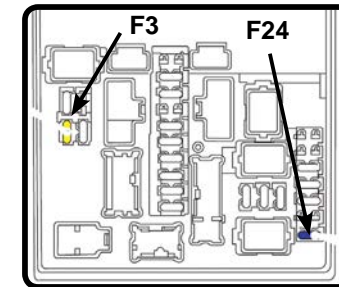

Fuse Box

ALTERNATE PROCEDURE 2

1. Locate and lift the carpet flap behind the center console.
2. Remove access cover bolts and cover (10 mm hex bolts).
3. Remove the service plug by (1) pull up and release the green lever, (2) press the locking tab to release and rotate, (3) pull the service plug out completely.
4. Disconnect negative 12V battery cable (under hood).

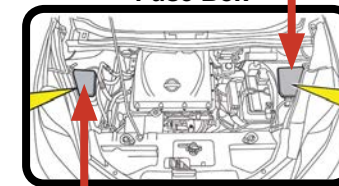

2 Fuse Boxes

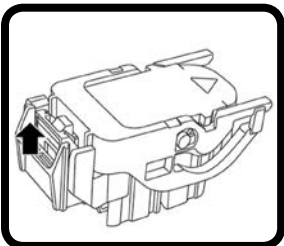

Pull Up and Release

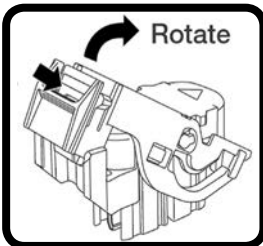

Release and Rotate

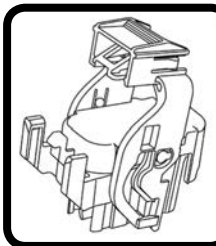

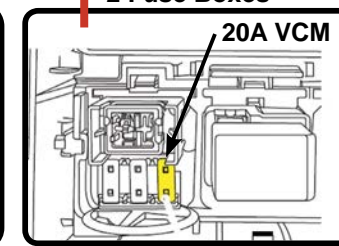

Pull Plug Out



Fuse Box

WARNINGS (continued on the next page)

-  NEVER cut, breach, or touch orange high voltage components or cabling. Doing so could result in serious injury or death.
-  The high voltage system may remain powered for up to 10 minutes after the vehicle is disabled. The HV system will be below 60V after 5 minutes.
-  SRS may remain powered for up to 3 minutes after vehicle is disabled.

NISSAN LEAF

NISSAN



2013-17

Zero Emission



LEAF

NISSAN

Li-ion (continued) **EXTRICATION INFORMATION**

See pages 15, 22.

WARNINGS (continued)

- Removal of service plug requires the use of electrical PPE (insulated gloves, shoes, and face shield).
- In the event of a fire involving a charging station, reference the **FIRE** portion of this guide, and treat it as an energized electrical fire until power to the charger can be shut down.
- This vehicle does not have an internal combustion engine. Lack of engine noise does not mean vehicle is OFF. Silent movement capability exists until vehicle is fully shut down.

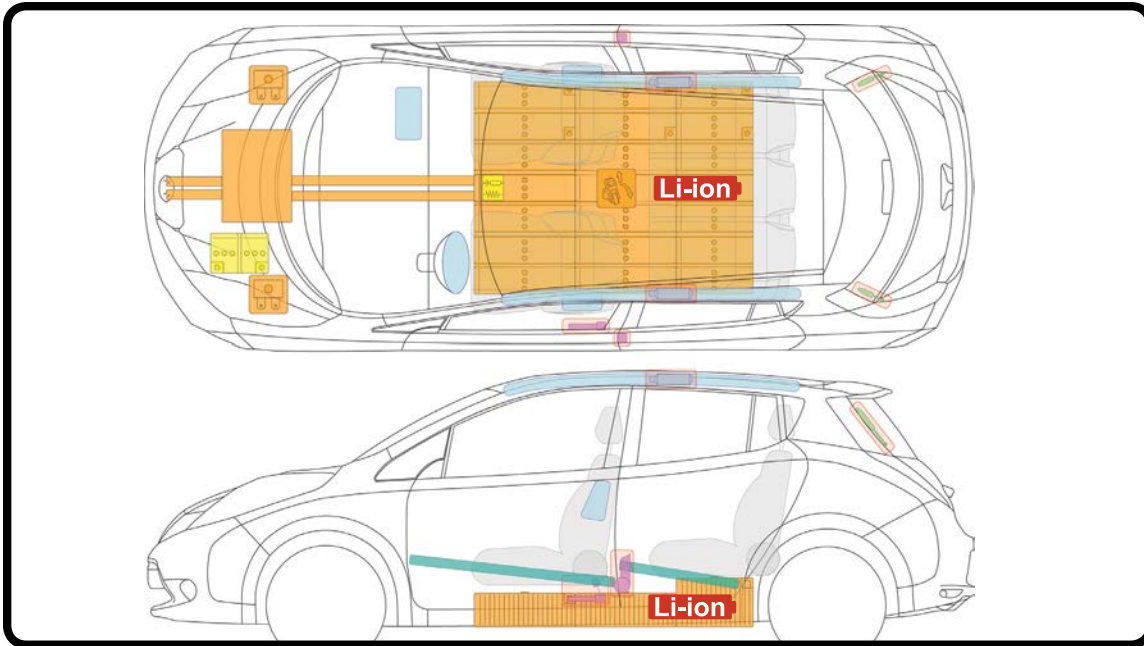

LEGEND

	Airbag		Bodywork Reinforcements		SRS Control Unit
	Stored Gas Inflator		Support Cylinder for Hood		12V Battery
	Seatbelt Tensioner or Pretensioner				High-Voltage Power Cable
	High-Voltage Battery		Emergency Disconnect (Remove Fuse)		Emergency Disconnect (Remove Plug)

STORAGE

The service disconnect should be removed prior to vehicle storage.

For towing and post-incident instructions, see the **POST-INCIDENT** section on page 20.



2018

Zero Emission



VEHICLE INFORMATION

Li-ion
See pages 15, 22.

IMMOBILIZE VEHICLE

- 1. **Chock the wheels.**
- 2. **Set parking brake.**
(pull up on push/pull switch, center console)
- 3. **Place vehicle into park.**
(push P in joystick, center console)

DISABLE VEHICLE

Determine if the vehicle is ON by presence of READY indicator:  (located on the lower dash display)

PRIMARY PROCEDURE

- 1. If ON, turn off vehicle by pressing power button.
- 2. Verify READY indicator is OFF.
- 3. If possible, keep proximity key at least 16 feet (5 meters) away from vehicle.
- 4. Disconnect negative 12V battery cable (under hood).

ALTERNATE PROCEDURE 1

- 1. Open the fuse box (under hood).
- 2. Remove F/S1 RLY fuse (blue). If correct fuse cannot be identified, pull all fuses in fuse box.
- 3. Disconnect negative 12V battery cable (under hood).

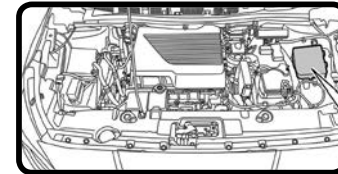

Fuse Box

ALTERNATE PROCEDURE 2

- 1. Locate and lift the carpet flap behind the center console.
- 2. Remove access cover bolts and cover (10 mm hex bolts).
- 3. Remove the service plug by (1) pull up and release the green lever, (2) press the locking tab to release and rotate, (3) pull the service plug out completely.
- 4. Disconnect negative 12V battery cable (under hood).

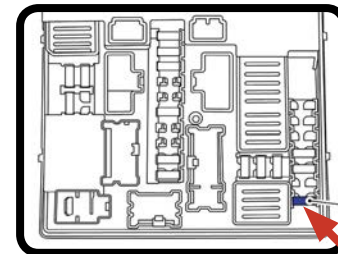

F/S1 RLY Fuse (blue)

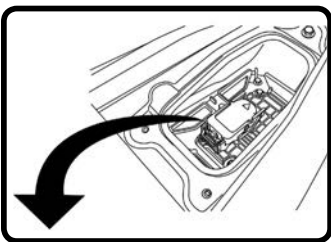

Service Plug

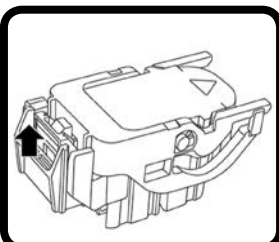

Pull Up and Release

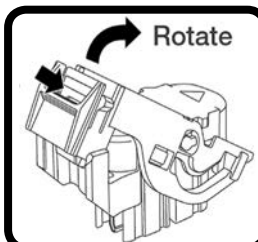

Release and Rotate

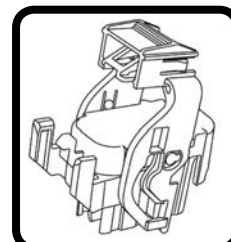

Pull Plug Out

WARNINGS (continued on the next page)



NEVER cut, breach, or touch orange high voltage components or cabling. Doing so could result in serious injury or death.



The high voltage system may remain powered for up to 10 minutes after the vehicle is disabled. The HV system will be below 60V after 5 minutes.



SRS may remain powered for up to 3 minutes after vehicle is disabled.

NISSAN

NISSAN

LEAF



2018

Zero Emission



LEAF

NISSAN

Li-ion (continued) **EXTRICATION INFORMATION**

See pages 15, 22.

WARNINGS (continued)

- ⚠ Removal of service plug requires the use of electrical PPE (insulated gloves, shoes, and face shield).
- ⚠ In the event of a fire involving a charging station, reference the **FIRE** portion of this guide, and treat it as an energized electrical fire until power to the charger can be shut down.
- ⚠ This vehicle does not have an internal combustion engine. Lack of engine noise does not mean vehicle is OFF. Silent movement capability exists until vehicle is fully shut down.

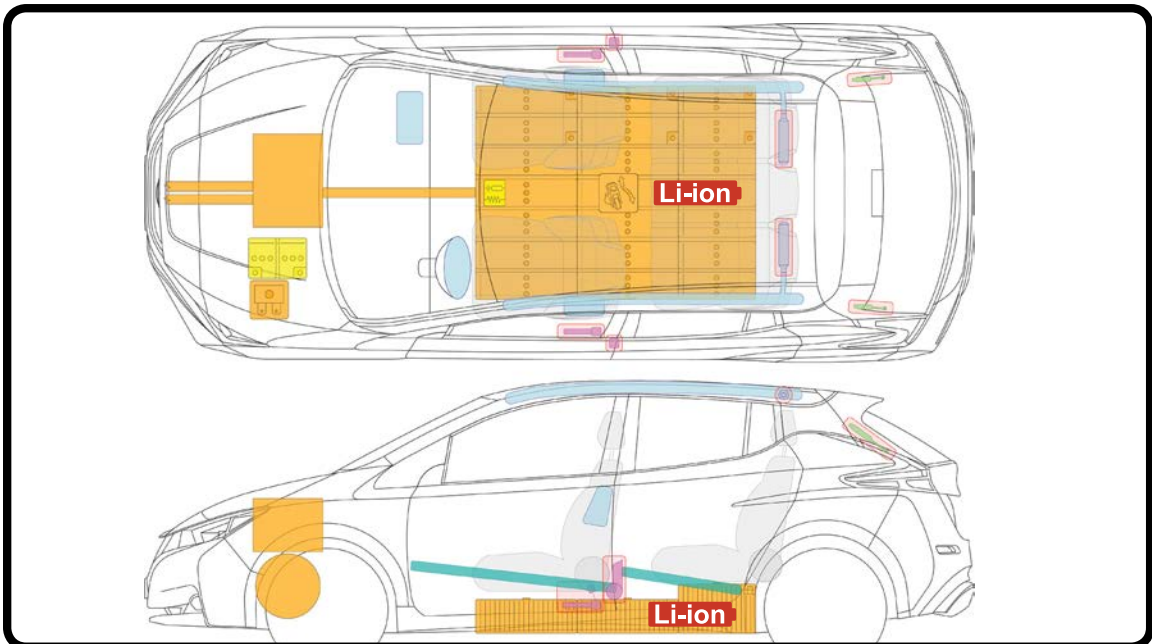

LEGEND			
	Airbag		Bodywork Reinforcements
	Stored Gas Inflator		Support Cylinder for Hood
	Seatbelt Tensioner or Pretensioner		SRS Control Unit
	High-Voltage Battery		12V Battery
	Emergency Disconnect (Remove Fuse)		High-Voltage Power Cable
	Emergency Disconnect (Remove Plug)		Li-ion

STORAGE

The service disconnect should be removed prior to vehicle storage.

For towing and post-incident instructions, see the **POST-INCIDENT** section on page 20.



2016

PURE DRIVE
HYBRID



VEHICLE INFORMATION

Li-ion

See pages 15, 22.

IMMOBILIZE VEHICLE

1. **Chock the wheels.**
2. **Set parking brake.**
(foot pedal)
3. **Place vehicle into park.**
(center console)

DISABLE VEHICLE

Determine if the vehicle is ON by presence of READY indicator:  (located on the lower dash display)

PRIMARY PROCEDURE

1. If ON, turn off vehicle, press power button.
2. Verify READY indicator is OFF.
3. If possible, keep proximity key at least 16 feet (5 meters) away from vehicle.
4. Disconnect negative 12V battery cable (under hood, under motor cover).

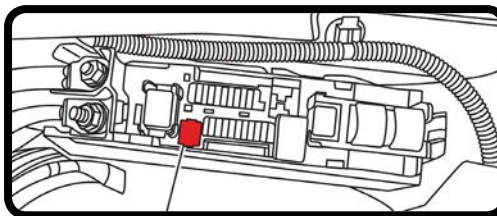

Remove Fuse F/L IGCT RLY 50A (red)

ALTERNATE PROCEDURE 1

1. Open under-hood fuse box.
2. Remove F/L IGCT RLY 50A fuse (red). If correct fuse cannot be identified, pull all fuses in fuse box.
3. Disconnect negative 12V battery cable (under hood, under motor cover).

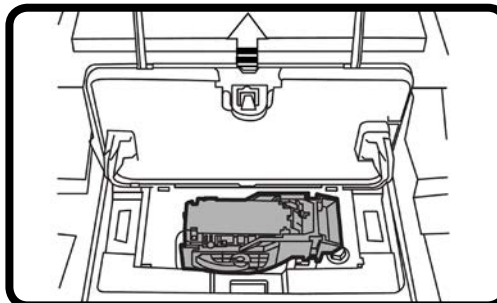





Service Plug In Center Console

ALTERNATE PROCEDURE 2

1. Open center console and remove service plug cover.
2. Remove the service plug by (1) pull service plug lever, (2) release lever locking tab, (3) rotate green lever outward, (4) pull the service plug out completely. (See next page for detail diagram)
3. Disconnect negative 12V battery cable (under hood, under motor cover).

WARNINGS

-  NEVER cut, breach, or touch orange high voltage components or cabling. Doing so could result in serious injury or death.
-  The high voltage system may remain powered for up to 10 minutes after the vehicle is disabled.
-  SRS may remain powered for up to 3 minutes after vehicle is disabled.
-  Removal of service plug requires use of electrical PPE (insulated gloves, shoes, and face shield).
-  Lack of engine noise does not mean vehicle is OFF. Silent movement or instant restart capability exists until vehicle is fully shut down.

NISSAN

NISSAN

MURANO

HEV



2016

PURE DRIVE
HYBRID









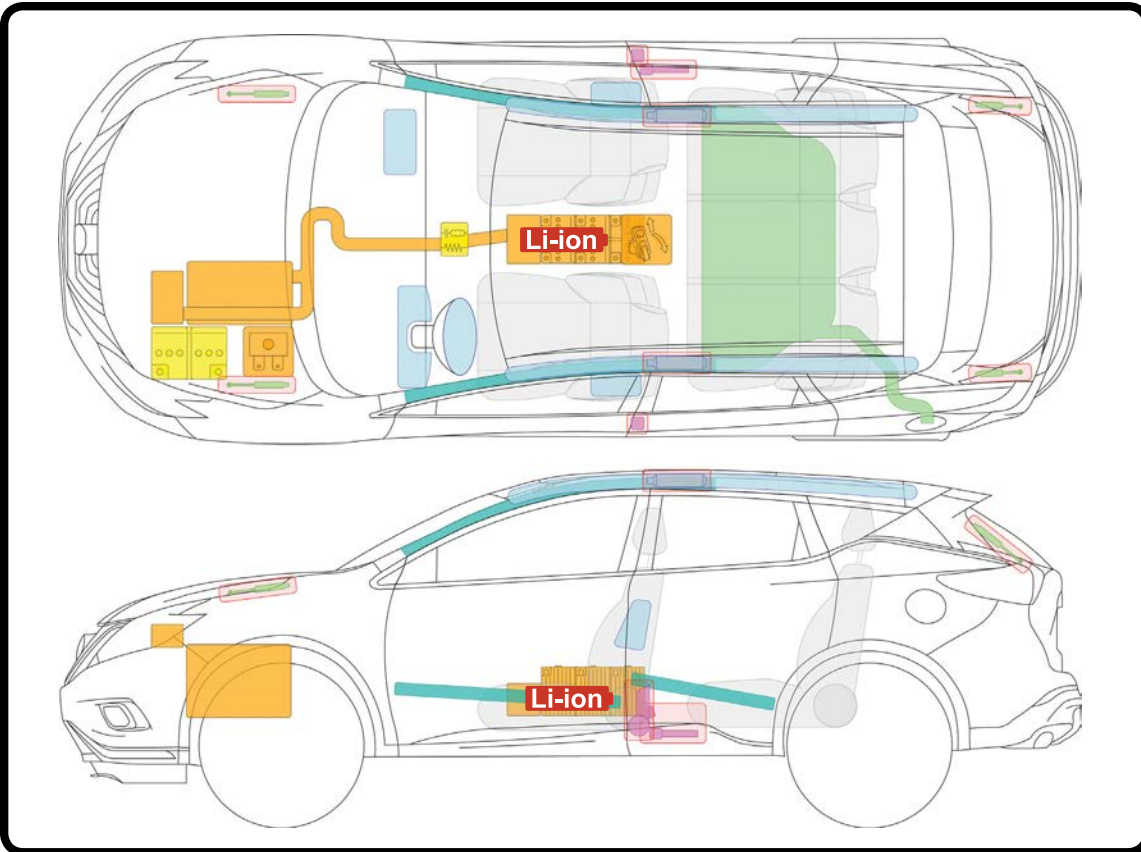





MURANO

Li-ion (continued) **EXTRICATION INFORMATION**

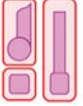
See pages 15, 22.



LEGEND

 Airbag	 Bodywork Reinforcements	 SRS Control Unit
 Stored Gas Inflator	 Support Cylinder for Hood	 12V Battery
 Seatbelt Tensioner or Pretensioner	 Fuel Tank	 High-Voltage Power Cable
 High-Voltage Battery	 Emergency Disconnect (Remove Fuse)	 Emergency Disconnect (Remove Plug)

STORAGE

The service disconnect should be removed prior to vehicle storage.

For towing and post-incident instructions, see the **POST-INCIDENT** section on page 20.

NISSAN



2014-15

PURE DRIVE
HYBRID



VEHICLE INFORMATION

Li-ion
See pages 15, 22.

IMMOBILIZE VEHICLE

- 1. **Chock the wheels.**
- 2. **Set parking brake.** (foot pedal)
- 3. **Place vehicle into park.** (center console)

DISABLE VEHICLE

Determine if the vehicle is ON by presence of READY indicator:  (located on the lower dash display)

PRIMARY PROCEDURE

- 1. If ON, turn off vehicle, press power button.
- 2. Verify READY indicator is OFF.
- 3. If possible, keep proximity key at least 16 feet (5 meters) away from vehicle.
- 4. Disconnect negative 12V battery cable (under hood).



12V Battery Disconnect

ALTERNATE PROCEDURE 1

- 1. Open under-hood fuse box.
- 2. Remove fuse F/L V IGCT RLY 50A (red). If correct fuse cannot be identified, pull all fuses in fuse box.
- 3. Disconnect negative 12V battery cable (under hood).









Remove Fuse F/L V IGCT RLY (red)

ALTERNATE PROCEDURE 2

- 1. Open luggage compartment and lift luggage floor board.
- 2. Remove the service plug by (1) pull service plug lever, (2) release lever locking tab, (3) rotate green lever outward, (4) pull the service plug out completely. (See next page for detail diagram)
- 3. Disconnect negative 12V battery cable (under hood).

WARNINGS

-  NEVER cut, breach, or touch orange high voltage components or cabling. Doing so could result in serious injury or death.
-  The high voltage system may remain powered for up to 10 minutes after the vehicle is disabled.
-  SRS may remain powered for up to 3 minutes after vehicle is disabled.
-  Removal of service plug requires use of electrical PPE (insulated gloves, shoes, and face shield)
-  High voltage cables on the underside of the vehicle are encased in a black plastic protector, hiding them from sight.
-  Lack of engine noise does not mean vehicle is OFF. Silent movement or instant restart capability exists until vehicle is fully shut down.

NISSAN

NISSAN
PATHFINDER

HEV



2014-15



PATHFINDER

NISSAN

Li-ion (continued) **EXTRICATION INFORMATION**

See pages 15, 22.

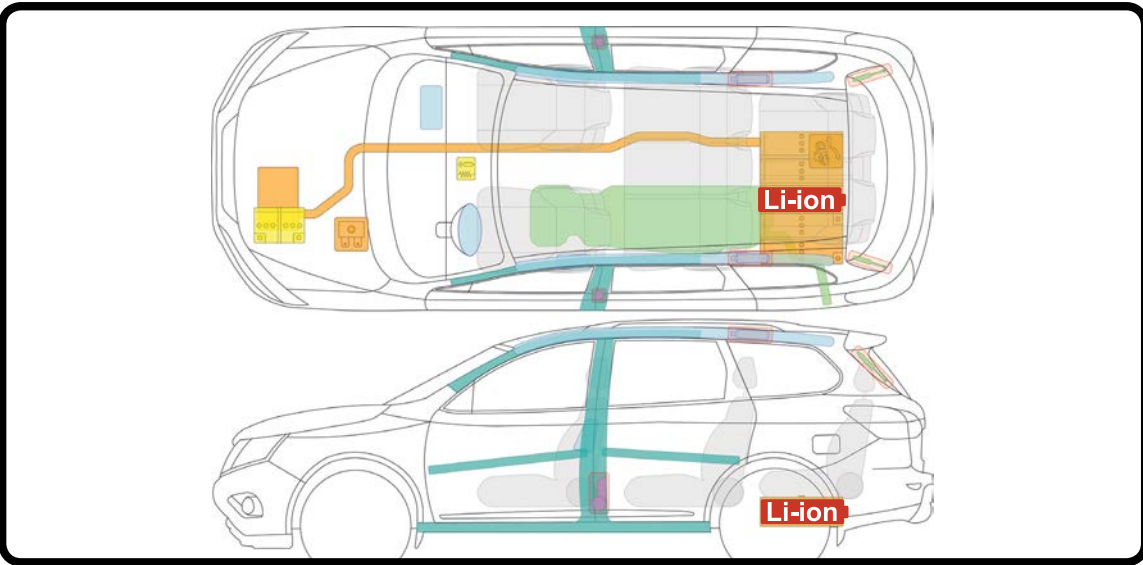

LEGEND		
	Airbag	
	Stored Gas Inflator	
	Seatbelt Tensioner or Pretensioner	
	High-Voltage Battery	
	Bodywork Reinforcements	
	Support Cylinder for Hood	

REMOVING THE SERVICE DISCONNECT (DETAIL)



Service Plug Access Under Luggage Floor Board



1. Pull Lever
2. Release Locking Tab



3. Rotate Lever
4. Pull Out Plug

STORAGE

The service disconnect should be removed prior to vehicle storage.

For towing and post-incident instructions, see the **POST-INCIDENT** section on page 20.



2017-18

PURE DRIVE
HYBRID



VEHICLE INFORMATION

Li-ion

See pages 15, 22.

IMMOBILIZE VEHICLE

1. **Chock the wheels.**
2. **Set parking brake.**
(foot pedal)
3. **Place vehicle into park.**
(center console)

DISABLE VEHICLE

Determine if the vehicle is ON by presence of READY indicator:  (located on the lower dash display)

PRIMARY PROCEDURE

1. If ON, turn off vehicle, press power button.
2. Verify READY indicator is OFF.
3. If possible, keep proximity key at least 16 feet (5 meters) away from vehicle.
4. Disconnect negative 12V battery cable (luggage compartment, under floor board).

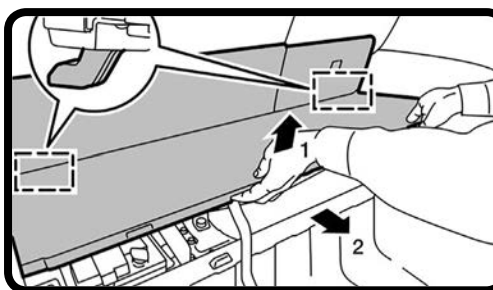

12V Battery Location

ALTERNATE PROCEDURE 1

1. Open under-hood fuse box.
2. Remove fuse F/L 50A IGCT RLY (red). If correct fuse cannot be identified, pull all fuses in fuse box.
3. Disconnect negative 12V battery cable (luggage compartment, under floor board).

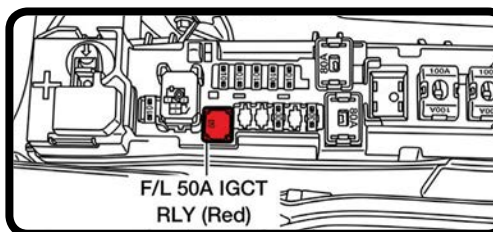





Remove Fuse F/L 50A IGCT RLY (red)

ALTERNATE PROCEDURE 2

1. Open luggage compartment and lift luggage floor board.
2. Remove the service plug by (1) pull service plug lever, (2) release lever locking tab, (3) rotate green lever outward, (4) pull the service plug out completely. (See next page for detail diagram)
3. Disconnect negative 12V battery cable (luggage compartment, under floor board).

WARNINGS

-  NEVER cut, breach, or touch orange high voltage components or cabling. Doing so could result in serious injury or death.
-  The high voltage system may remain powered for up to 10 minutes after the vehicle is disabled.
-  SRS may remain powered for up to 3 minutes after vehicle is disabled.
-  Removal of service plug requires use of electrical PPE (insulated gloves, shoes, and face shield)
-  Lack of engine noise does not mean vehicle is OFF. Silent movement or instant restart capability exists until vehicle is fully shut down.

NISSAN

NISSAN

ROGUE

HEV



2017-18



ROGUE

Li-ion (continued) **EXTRICATION INFORMATION**

See pages 15, 22.

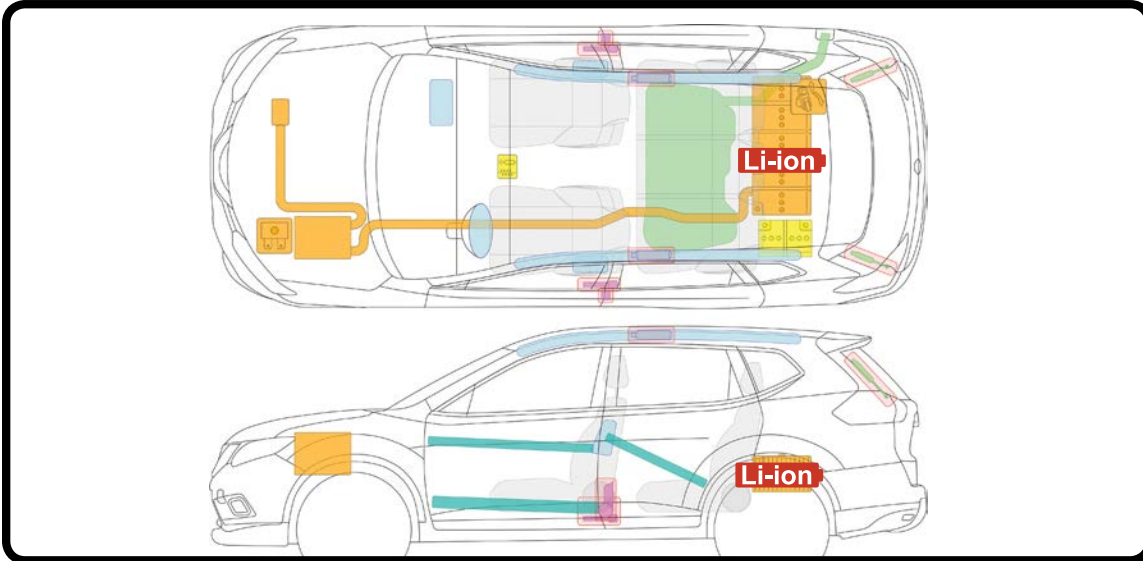

LEGEND		
Airbag	Bodywork Reinforcements	SRS Control Unit
Stored Gas Inflator	Support Cylinder for Hood	12V Battery
Seatbelt Tensioner or Pretensioner	Fuel Tank	High-Voltage Power Cable
High-Voltage Battery	Emergency Disconnect (Remove Fuse)	Emergency Disconnect (Remove Plug)

REMOVING THE SERVICE DISCONNECT (DETAIL)



Service Plug Access Under Luggage Floor Board



1. Pull Lever
2. Release Locking Tab



3. Rotate Lever
4. Pull Out Plug

STORAGE

The service disconnect should be removed prior to vehicle storage.

For towing and post-incident instructions, see the **POST-INCIDENT** section on page 20.

NISSAN



2015-19

NOVABUS

VEHICLE INFORMATION



See page 25.

IMMOBILIZE VEHICLE

1. Chock the wheels.
2. Set parking brake.
(yellow knob, driver's left)
3. Place vehicle into neutral.
(gear selector)

DISABLE VEHICLE

PRIMARY PROCEDURE

1. Turn the master power switch to the OFF position (driver's left panel).
2. Turn the 12/24V battery disconnect switch to the OFF position (street-side rear fender access door).
3. Turn the emergency shut-off valve, 1/4 turn to the OFF position (rear street-side access door).

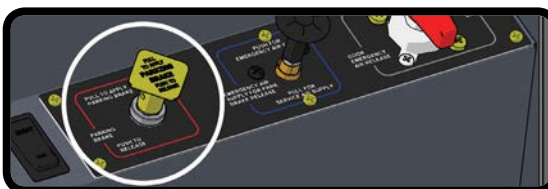

Parking Brake (Yellow Knob)

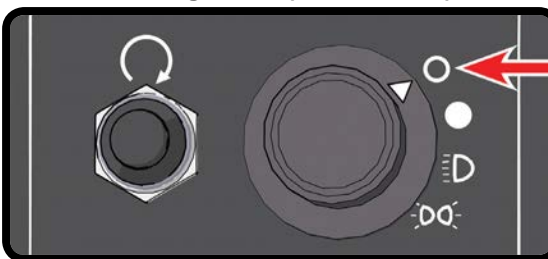

Power Switch Off Position

ALTERNATE PROCEDURE

(if curb-side access door is not accessible)

1. Turn the master power switch to the OFF position (driver's left panel).
2. Turn the 12/24V battery disconnect switch to the OFF position (street-side rear fender access door).
3. Turn all manual valves on CNG cylinders to the OFF position (bus roof-top).

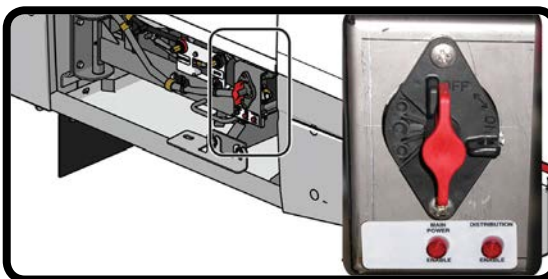

12/24V Battery Disconnect (OFF position)



Emergency Shut-Off Valve (OFF position)

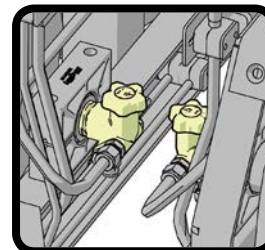

Manual CNG Shut-Off Valves (roof-top)

WARNINGS

- Do NOT cut CNG fuel lines as they may contain natural gas even after the system is disabled.
- Use a combustible gas meter to monitor for any potential leaks in the CNG system.
- Natural gas becomes flammable at concentrations between 5% and 15% in air.

NOVABUS

LFS

NOVA BUS





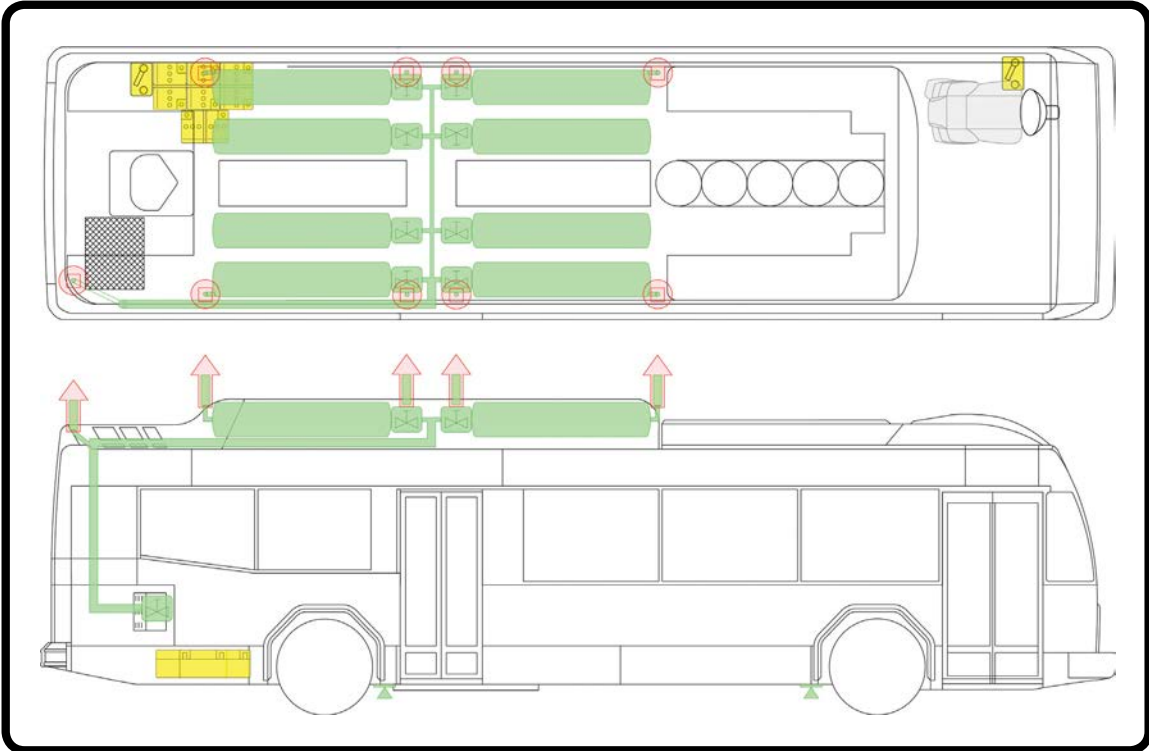

 See page 25.

(continued)

EXTRICATION INFORMATION



LEGEND		
 12V Battery	 Fuel Tank	
	 Emergency Disconnect (Switch Off)	 Pressure Relief Valve

SPECIAL CONCERNS

ENGINE COMPARTMENT FIRE SUPPRESSION SYSTEM

The fire detection and suppression system can be activated both manually and automatically.

AUTOMATIC ACTUATION

In the automatic mode, if there is a fire or overheat condition, a detector located in the area of the fire will cause an audible alarm in the operator's compartment, and discharge ammonium phosphate in the overheated area.

MANUAL ACTUATION

In the manual mode, the operator can activate the fire suppression system by pulling the locking pin and by striking down hard on the actuator knob of the emergency valve, located on the lateral console beside the operator.

For towing and post-incident instructions, see the **POST-INCIDENT** section on page 20.



2016-19

NOVA BUS

VEHICLE INFORMATION

Li-ion
See pages 15, 22.

IMMOBILIZE VEHICLE

- 1. **Chock the wheels.**
- 2. **Set parking brake.**
(knob, driver's left)
- 3. **Place vehicle into neutral.**
(gear selector)

DISABLE VEHICLE

PRIMARY PROCEDURE

- 1. Turn the master power switch to the OFF position (driver's left panel).
- 2. Turn the 12/24V battery disconnect switch to the OFF position (street-side rear fender access door).



Parking Brake Knob

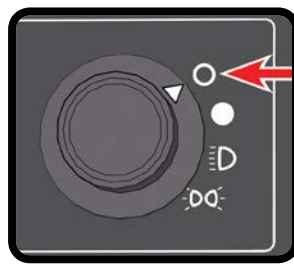

Power Switch Off

ALTERNATE PROCEDURE 1

- 1. Push the emergency shutdown switch (upper left instrument panel).
- 2. Turn the 12/24V battery disconnect switch to the OFF position (street-side rear fender access door).

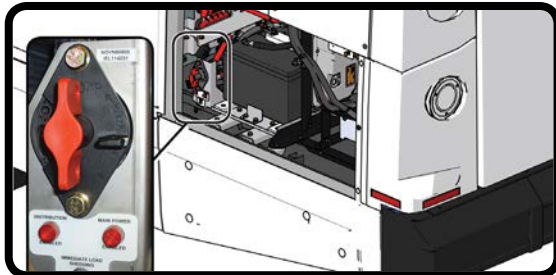

12/24V Battery Disconnect (OFF position)

ALTERNATE PROCEDURE 2

- 1. Turn the 12/24V battery disconnect switch to the OFF position (street-side rear fender access door).

ALTERNATE PROCEDURE 3

- 1. Cut the high voltage interlock loop wire (yellow wire in either curb-side access door or on roof-top).

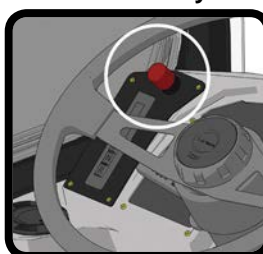

Emergency Shut-Off Switch

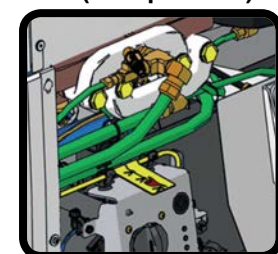

High Voltage Interlock Loop Yellow Wire

WARNINGS

- NEVER cut, breach, or touch high voltage components or cabling. Doing so could result in serious injury or death.
- When shutting down the high voltage system wait at least 10 minutes for complete discharge of the high voltage capacitor.
- The high voltage system may remain powered for up to 4 minutes after shutoff/disabling.
- Operating voltage of the hybrid drive system is 630 volts! Lithium-ion batteries are used in the HV system.
- This vehicle does not have an internal combustion engine. Lack of engine noise does not mean vehicle is OFF. Silent movement capability exists until vehicle is fully shut down.

NOVA BUS



NOVA BUS

2016-19







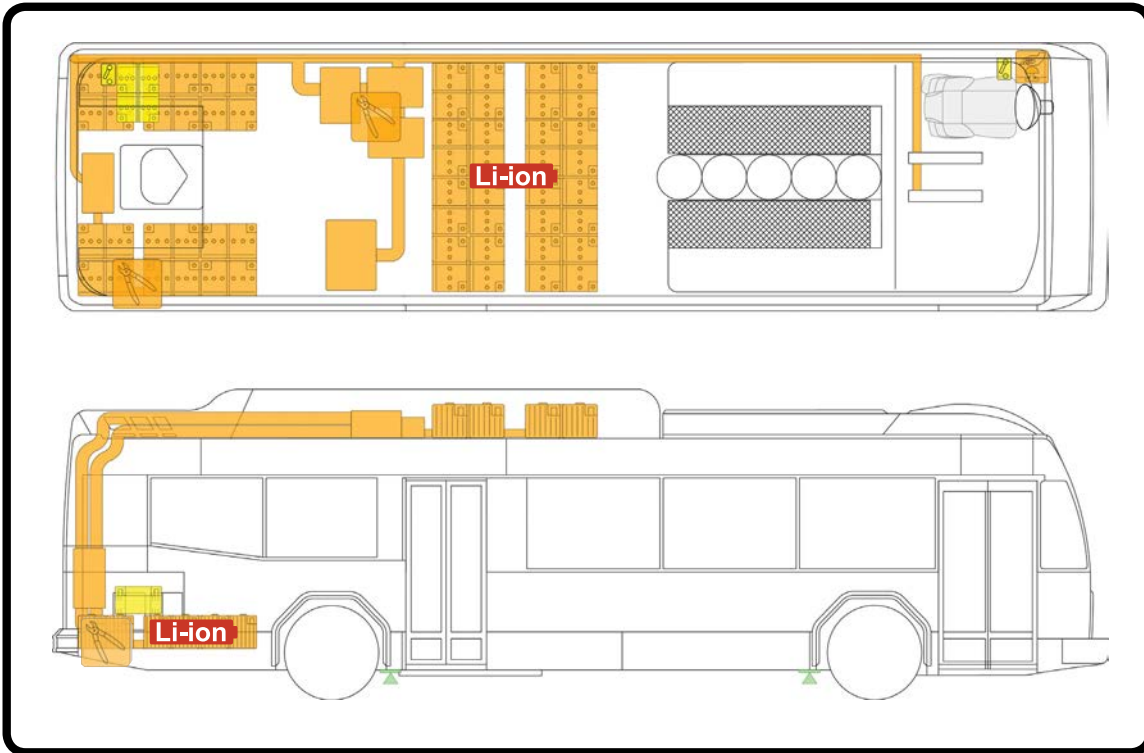

Li-ion (continued) **EXTRICATION INFORMATION**

See pages 15, 22.



LEGEND

	12V Battery		Emergency Disconnect (Cut Cable)		High-Voltage Power Cable
	High-Voltage Battery		Emergency Disconnect (Switch Off)		Emergency Shut Down Button

For towing and post-incident instructions, see the **POST-INCIDENT** section on page 20.



2015

e-hybrid



PORSCHE

PORSCHE

918 Spyder

VEHICLE INFORMATION

IMMOBILIZE VEHICLE

1. **Chock the wheels.**
2. **Set parking brake.**
(push-button, dashboard left of center console)
3. **Place vehicle into park.**
(gear selector, dashboard left of center console)

DISABLE VEHICLE

Determine if vehicle is ON by illumination of READY indicator and digital displays.

PRIMARY PROCEDURE

1. If ON, turn the key to the OFF position (dashboard, left side), and remove key.
2. Open the cover on the 12V service plug at the right in the passenger's footwell.
3. Release service plug by pressing the release hook back slightly and unlock the service plug.

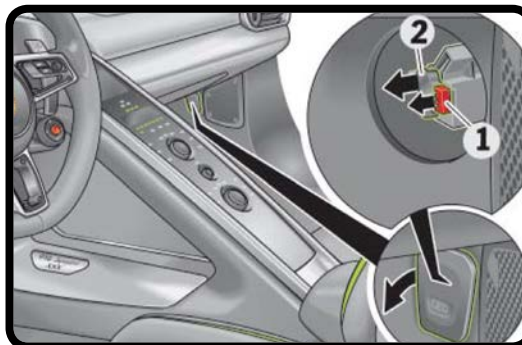

12V Battery Disconnect

ALTERNATE PROCEDURE

(if the 12V service plug is not accessible)

1. Turn the key to the OFF position (dashboard, left side), and remove key.
2. Open the cover on the fuse box at the left in the driver's footwell.
3. Pull out fuse number B-6 (7.5 A).

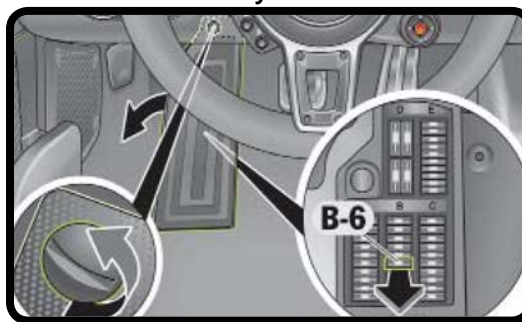

Remove Fuse B-6 (7.5 A)

NOTE: Neither of the above procedures will disable the airbags or SRS system. Disable procedure is located on the following page.

WARNINGS

- NEVER cut, breach, or touch high voltage components or cabling. Doing so could result in serious injury or death.
- The high voltage system may remain powered for up to 20 seconds after vehicle is shut off.
- Airbags and SRS may remain powered for up to 1 minute after shutoff/disabling. Avoid breaching SRS components.
- Lack of engine noise does not mean vehicle is OFF. Silent movement or instant restart capability exists until vehicle is fully shut down.











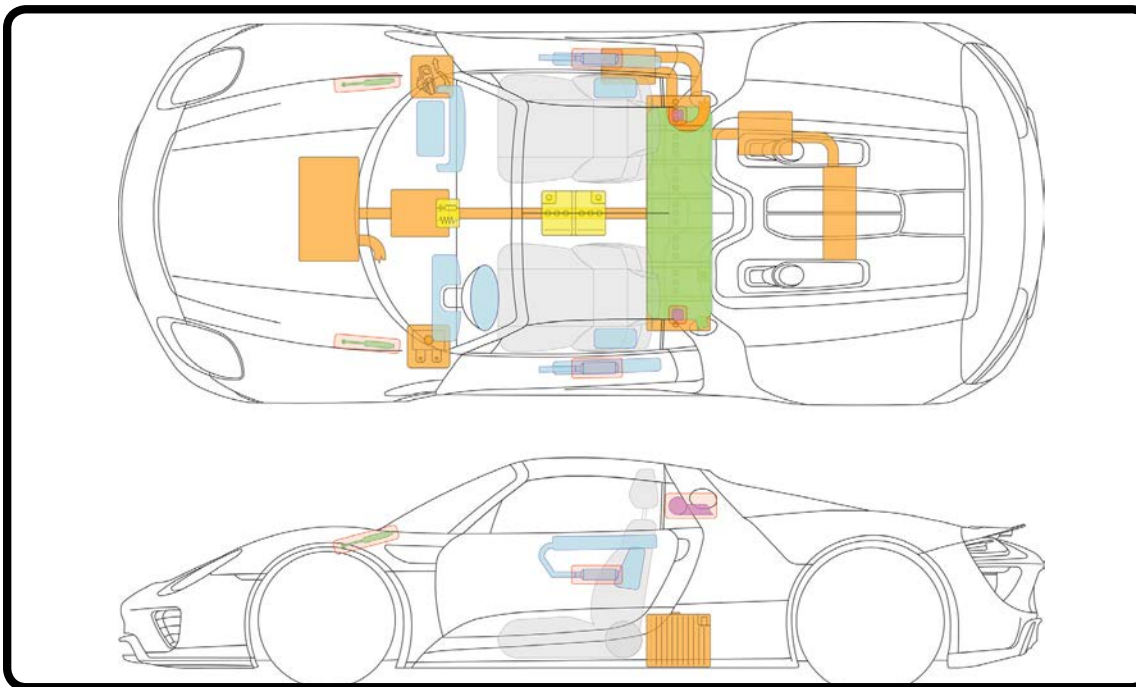

2015

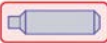
e-hybrid

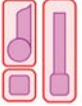

(continued) **EXTRICATION INFORMATION**



LEGEND		
 Airbag		 SRS Control Unit
 Stored Gas Inflator	 Support Cylinder for Hood	 12V Battery
 Seatbelt Tensioner or Pretensioner	 Fuel Tank	 High-Voltage Power Cable
 High-Voltage Battery	 Emergency Disconnect (Remove Fuse)	 Emergency Disconnect (Remove Plug)

DEACTIVATING AIRBAGS AND SRS

1. Loosen plastic clip and open the cover on the fuse box in the passenger's footwell.
2. Pull out fuse number C-4.

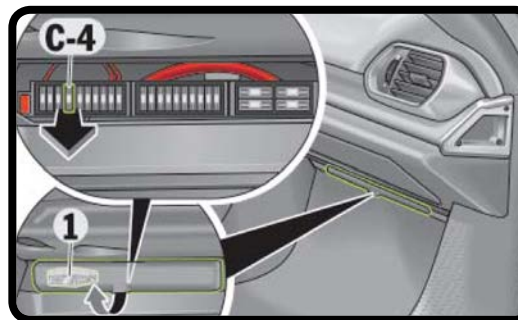

Remove Fuse C-4

For towing and post-incident instructions, see the **POST-INCIDENT** section on page 20.



2012-14

hybrid



PORSCHE

PORSCHE

Cayenne S

VEHICLE INFORMATION

IMMOBILIZE VEHICLE

- 1. Chock the wheels.
- 2. Set parking brake. (push-button, center console)
- 3. Place vehicle into park. (gear selector, center console)

DISABLE VEHICLE

Determine if vehicle is ON by illumination of READY indicator and digital displays.

PRIMARY PROCEDURE

- 1. If ON, turn the key to the OFF position (steering column, left side), remove key.
- 2. Move driver's seat all the way back and remove carpet flap.
- 3. Disconnect the ground cable from the 12V battery at the screw connectors.

ALTERNATE PROCEDURE

(if the ignition and 12V battery are not accessible)

- 1. Open the tailgate.
- 2. Disconnect the 12V plug connection (left of the HV battery).

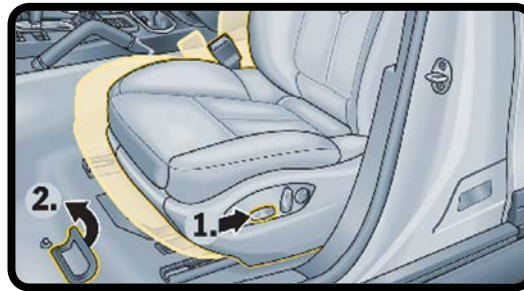

12V Battery Disconnect

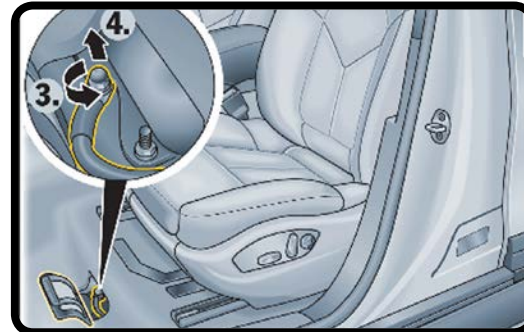



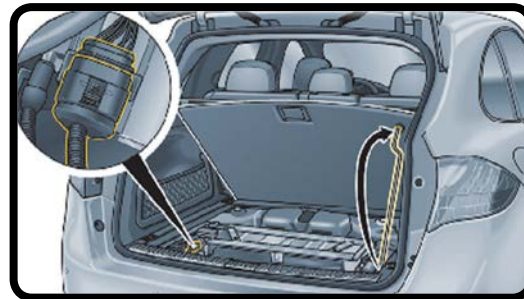

12V Battery Screws



12V Disconnect Plug

WARNINGS

-  NEVER cut, breach, or touch high voltage components or cabling. Doing so could result in serious injury or death.
-  The high voltage system may remain powered for up to 20 seconds after vehicle is shut off.
-  Airbags and SRS may remain powered for up to 1 minute after shutoff/disabling. Avoid breaching SRS components.
-  Lack of engine noise does not mean vehicle is OFF. Silent movement or instant restart capability exists until vehicle is fully shut down.



2012-14



(continued) **EXTRICATION INFORMATION**

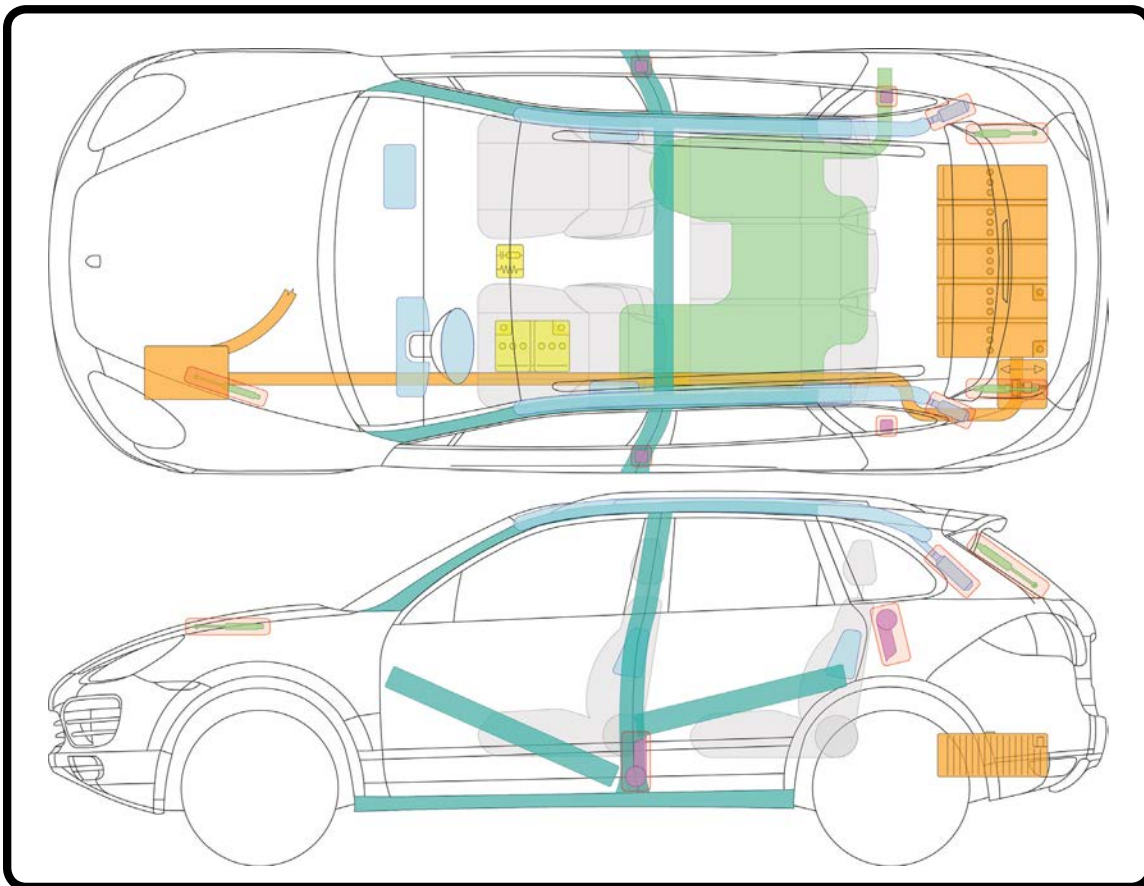

LEGEND		
Airbag	Bodywork Reinforcements	SRS Control Unit
Stored Gas Inflator	Support Cylinder for Hood	12V Battery
Seatbelt Tensioner or Pretensioner	Fuel Tank	High-Voltage Power Cable
High-Voltage Battery	Emergency Disconnect (Disconnect Plug)	

For towing and post-incident instructions, see the **POST-INCIDENT** section on page 20.



2015-18

e-hybrid



PORSCHE

VEHICLE INFORMATION

Li-ion

See pages 15, 22.

IMMOBILIZE VEHICLE

- 1. **Chock the wheels.**
- 2. **Set parking brake.**
(push/pull switch, left console)
- 3. **Place vehicle into park.**
(gear selector, center console)

DISABLE VEHICLE

Determine if vehicle is ON by READY indicator on tachometer and digital displays.

PRIMARY PROCEDURE

- 1. If ON, turn the key to the OFF position (left of steering wheel), and remove key.
- 2. Move driver's seat back and remove carpet flap. Disconnect the 12V battery ground cable at the screw connectors.

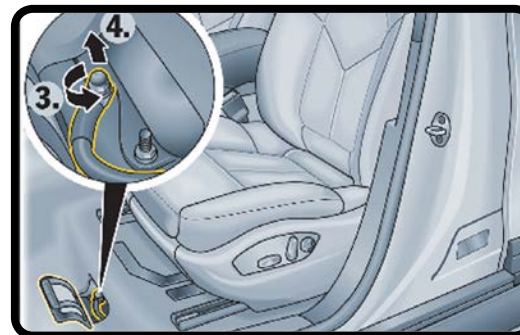

12V Battery Screws

ALTERNATE PROCEDURE

- 1. Move driver's seat back and remove carpet flap. Disconnect the 12V battery ground cable at the screw connectors.
- 2. Open the lid of the fuse box on the left-hand side of the dashboard.
- 3. Pull out fuse number 40.

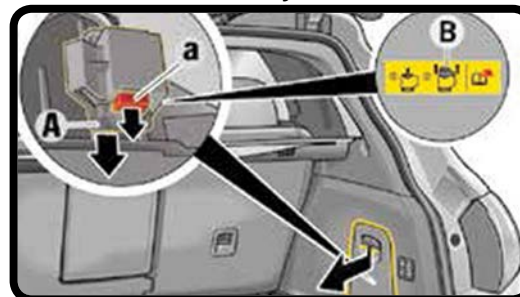

12V Disconnect Plug

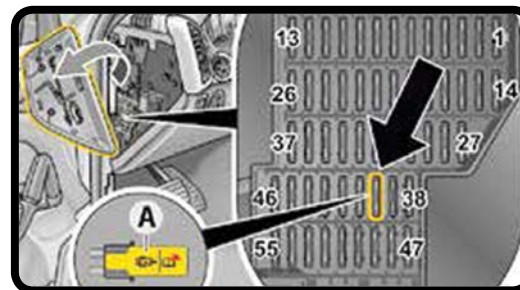

Fuse Box - Fuse 40 Location

WARNINGS

- NEVER cut, breach, or touch high voltage components or cabling. Doing so could result in serious injury or death.
- The high voltage system may remain powered for up to 20 seconds after vehicle is shut off.
- Airbags and SRS may remain powered for up to 1 minute after shutoff/disabling. Avoid breaching SRS components.
- Lack of engine noise does not mean vehicle is OFF. Silent movement or instant restart capability exists until vehicle is fully shut down.

PORSCHE Cayenne S e-hybrid



2015-18











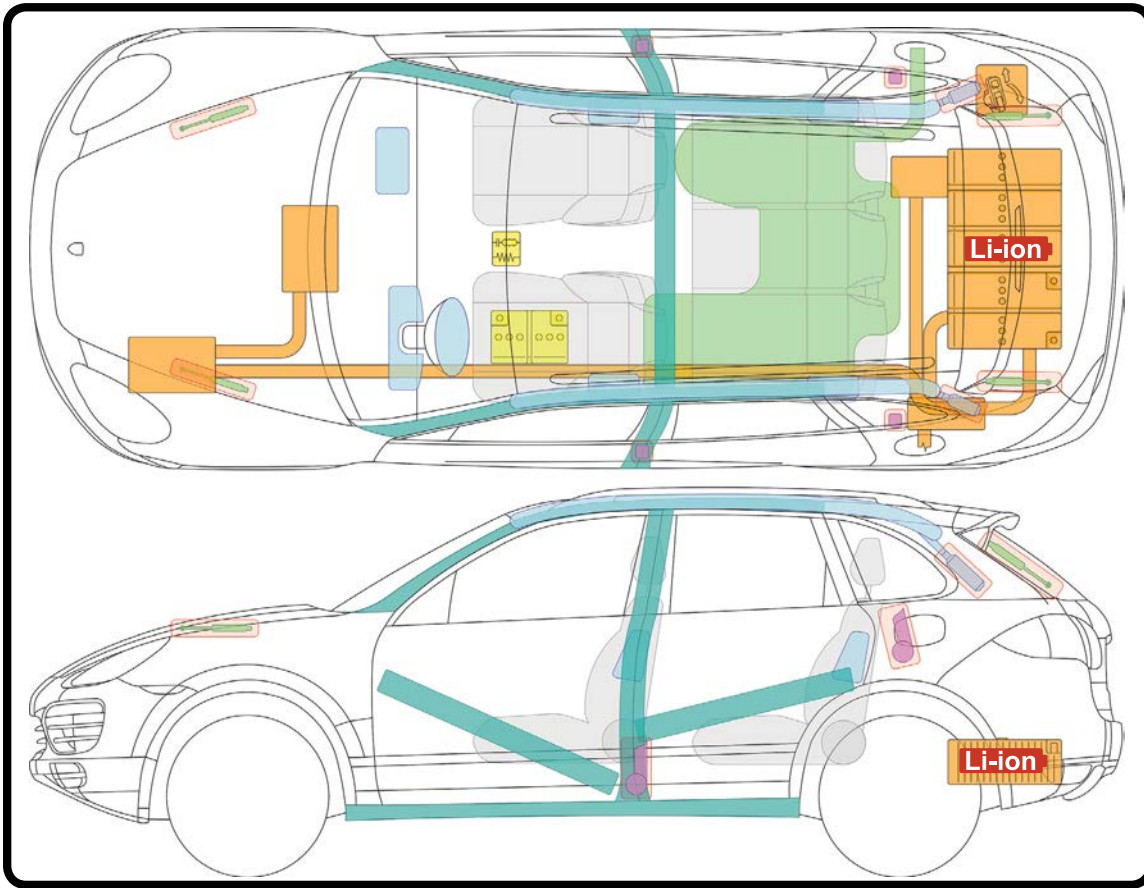

Cayenne S e-hybrid

PORSCHE

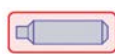
Li-ion (continued) **EXTRICATION INFORMATION**

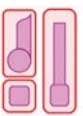
See pages 15, 22.



LEGEND		
 Airbag	 Bodywork Reinforcements	 SRS Control Unit
 Stored Gas Inflator	 Support Cylinder for Hood	 12V Battery
 Seatbelt Tensioner or Pretensioner	 Fuel Tank	 High-Voltage Power Cable
 High-Voltage Battery		 Emergency Disconnect (Remove Plug)

For towing and post-incident instructions, see the **POST-INCIDENT** section on page 20.



2012-13

hybrid



PORSCHE

PORSCHE Panamera S

VEHICLE INFORMATION

IMMOBILIZE VEHICLE

- 1. **Chock the wheels.**
- 2. **Set parking brake.**
(push/pull switch, left console)
- 3. **Place vehicle into park.**
(gear selector, center console)

DISABLE VEHICLE

Determine if vehicle is ON by illumination of READY indicator and digital displays.

PRIMARY PROCEDURE

- 1. If ON, turn the key to the OFF position (dashboard, left side), and remove key.
- 2. Remove the cover of the 12V battery on the rear left-hand side of the luggage compartment.
- 3. Disconnect the negative cable of the 12V battery and secure it to prevent accidental contact.

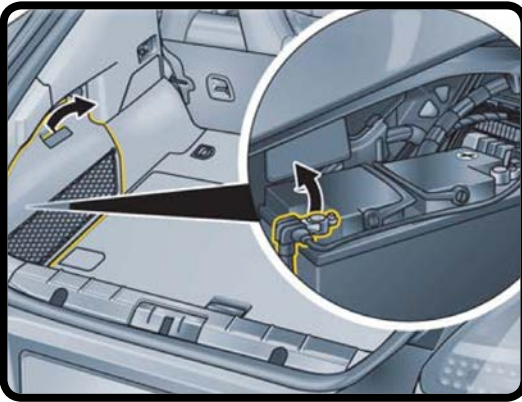

12V Battery Disconnect

ALTERNATE PROCEDURE

(if the ignition is not accessible)

- 1. Remove the cover of the 12V battery on the rear left-hand side of the luggage compartment.
- 2. Disconnect the negative cable of the 12V battery and secure it to prevent accidental contact.
- 3. Open the lid of the fuse box on the left-hand side of the dashboard.
- 4. Pull out fuse number 46.

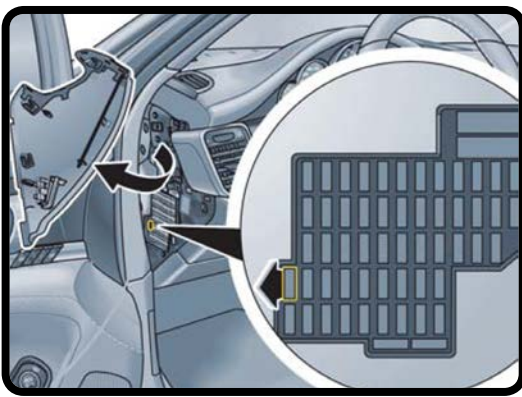

Fuse Box - Fuse 46 Location

WARNINGS

- NEVER cut, breach, or touch high voltage components or cabling. Doing so could result in serious injury or death.
- The high voltage system may remain powered for up to 20 seconds after vehicle is shut off.
- Airbags and SRS may remain powered for up to 1 minute after shutoff/disabling. Avoid breaching SRS components.
- Lack of engine noise does not mean vehicle is OFF. Silent movement or instant restart capability exists until vehicle is fully shut down.









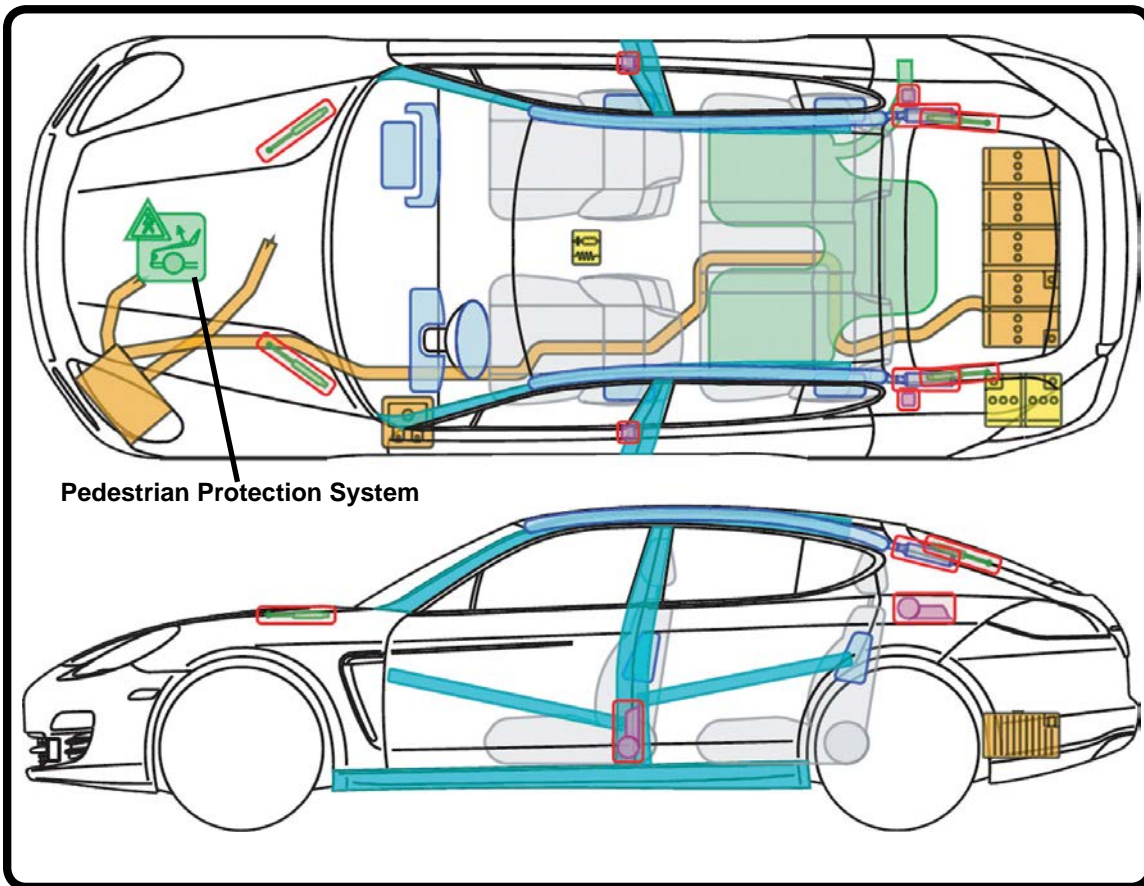





2012-13

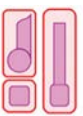

(continued) **EXTRICATION INFORMATION**



Pedestrian Protection System

LEGEND		
 Airbag	 Bodywork Reinforcements	 SRS Control Unit
 Stored Gas Inflator	 Support Cylinder for Hood	 12V Battery
 Seatbelt Tensioner or Pretensioner	 Fuel Tank	 High-Voltage Power Cable
 High-Voltage Battery	 Emergency Disconnect (Remove Fuse)	 Emergency Disconnect (Switch Off)

For towing and post-incident instructions, see the **POST-INCIDENT** section on page 20.



2014-16

e-hybrid



PORSCHE

PORSCHE

Panamera S e-hybrid

VEHICLE INFORMATION

IMMOBILIZE VEHICLE

1. **Chock the wheels.**
2. **Set parking brake.**
(push/pull switch, left console)
3. **Place vehicle into park.**
(gear selector, center console)

DISABLE VEHICLE

Determine if vehicle is ON by READY indicator on tachometer and digital displays.

PRIMARY PROCEDURE

1. If ON, turn the key to the OFF position (dashboard, left side), and remove key.
2. Locate the 12V service plug in the rear luggage compartment.
3. Unlock (a) and unplug (A) the service plug.

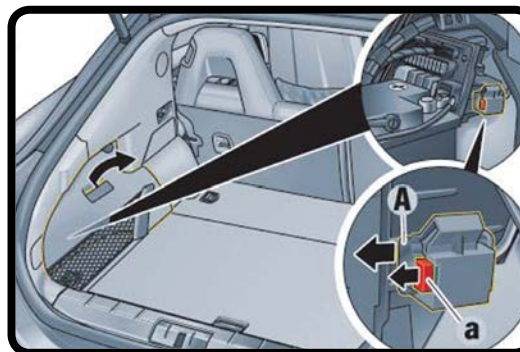

12V Service Plug Disconnect

ALTERNATE PROCEDURE

(if the ignition is not accessible)

1. Remove the cover of the 12V battery on the rear left-hand side of the luggage compartment.
2. Disconnect the negative cable of the 12V battery and secure it to prevent accidental contact.
3. Open the lid of the fuse box on the left-hand side of the dashboard.
4. Pull out fuse number 46.

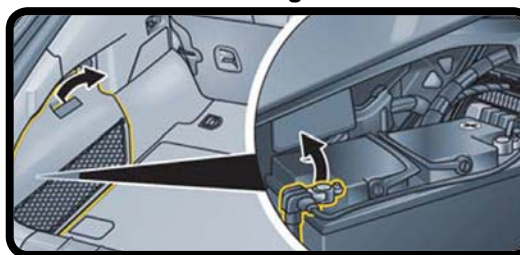



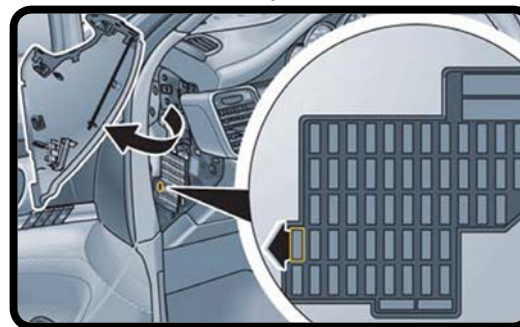

12V Battery Location



Fuse Box - Fuse 46 Location

WARNINGS

-  NEVER cut, breach, or touch high voltage components or cabling. Doing so could result in serious injury or death.
-  The high voltage system may remain powered for up to 20 seconds after vehicle is shut off.
-  Airbags and SRS may remain powered for up to 1 minute after shutoff/disabling. Avoid breaching SRS components.
-  Lack of engine noise does not mean vehicle is OFF. Silent movement or instant restart capability exists until vehicle is fully shut down.



2014-16



Panamera S e-hybrid

PORSCHE

(continued) **EXTRICATION INFORMATION**

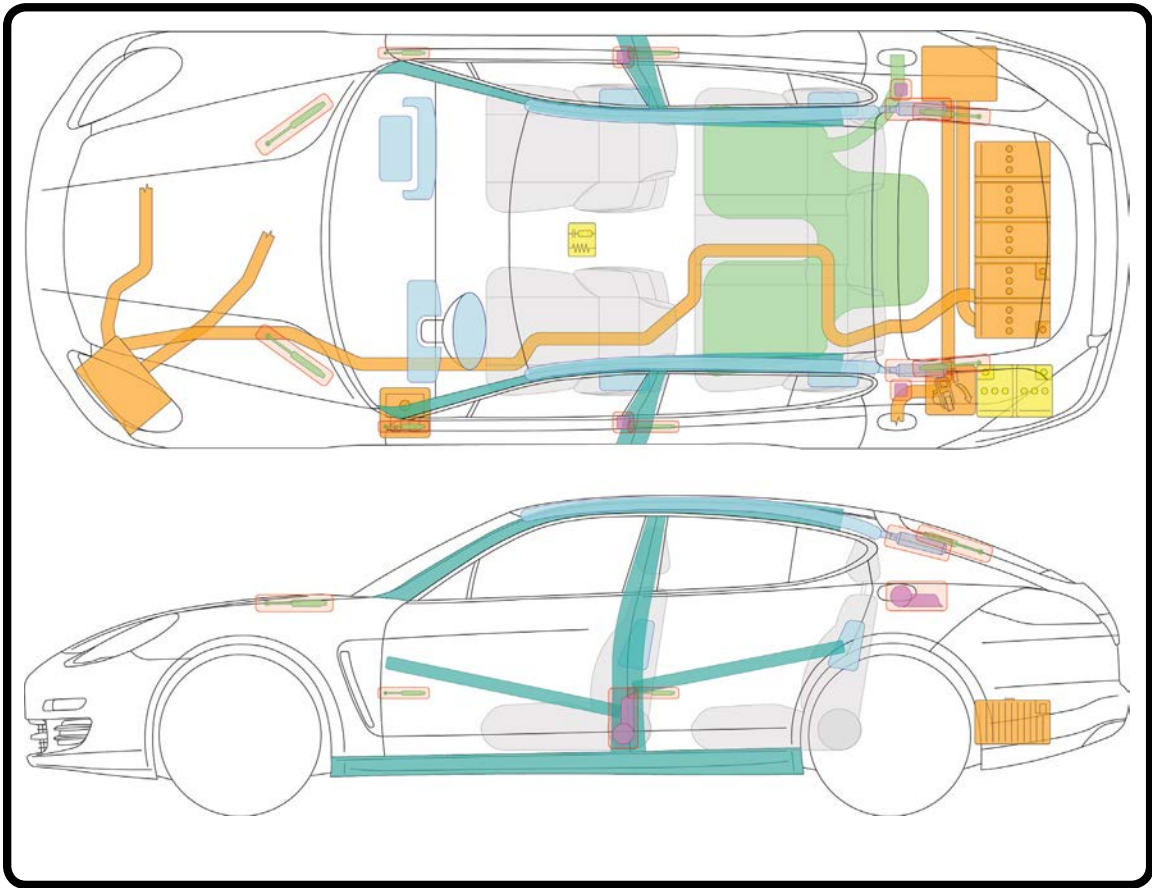

LEGEND		
Airbag	Bodywork Reinforcements	SRS Control Unit
Stored Gas Inflator	Support Cylinder for Hood	12V Battery
Seatbelt Tensioner or Pretensioner	Fuel Tank	High-Voltage Power Cable
High-Voltage Battery	Emergency Disconnect (Remove Fuse)	Emergency Disconnect (Remove Plug)

For towing and post-incident instructions, see the **POST-INCIDENT** section on page 20.



2010-15



PROTERRA

PROTERRA

EcoRide BE35

VEHICLE INFORMATION

IMMOBILIZE VEHICLE

1. Chock the wheels.
2. Set parking brake. (yellow knob, driver's left panel)
3. Place vehicle into park. (push-button, driver's left panel)

DISABLE VEHICLE

PRIMARY PROCEDURE

1. Turn the master power switch to the OFF position (lower left dashboard).
2. Open the curb-side rear fender (rear of the bus, push-button)
3. Turn the 12/24V emergency disconnect switches to the OFF position.



Parking Brake (Yellow Knob)



Power Switch Off Position

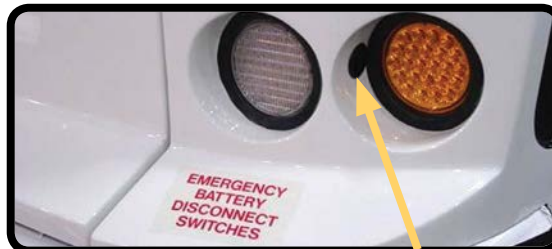



Curb-side Rear Fender Access Push-Button



Emergency Disconnect (OFF position)

WARNINGS

-  NEVER cut, breach, or touch orange high voltage components or cabling. Doing so could result in serious injury or death.
-  This vehicle does not have an internal combustion engine. Lack of engine noise does not mean vehicle is OFF. Silent movement capability exists until vehicle is fully shut down.



2010-15







PROTERRA

PROTERRA EcoRide BE35

(continued) **EXTRICATION INFORMATION**

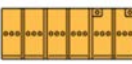

LEGEND				
	12V Battery			High-Voltage Power Cable
	High-Voltage Battery		Emergency Disconnect (Switch Off)	

For towing and post-incident instructions, see the **POST-INCIDENT** section on page 20.



2007-09



VEHICLE INFORMATION

IMMOBILIZE VEHICLE

1. Chock the wheels.
2. Set parking brake. (foot pedal)
3. Place vehicle into park. (center console)

DISABLE VEHICLE

Determine if vehicle is ON.

- Vehicle is ON if tachometer needle points to AUTO STOP.
- Vehicle is OFF if needle points to OFF.

PRIMARY PROCEDURE

1. If ON, turn the vehicle's ignition off (conventional key). Remove key.
2. Disconnect the 12V battery, negative cables (engine compartment).

NOTE: Since one of the 12V negative (-) cables is partially hidden from view, it is best to disconnect the cables from the terminal or cut the cables near the terminal.



Cut here to disable BOTH 12V negative cables at once.

ALTERNATE PROCEDURE

1. Disconnect the 12V battery, negative cables (engine compartment).
2. If the ignition key is not accessible, remove the Run/Crank Relay located in the underhood fuse block



Run/Crank Relay

MEDIUM VOLTAGE MANUAL DISCONNECT

Opening the hinged cover of the manual disconnect causes a spring-loaded disconnect switch to interrupt electrical flow from the medium voltage battery and quickly discharge stored electrical energy in the generator control module. (See next page for detail diagram.)

WARNINGS

- NEVER cut medium voltage components or blue cabling. Cutting presents an arc hazard. Medium voltage cabling is routed under vehicle in a metal conduit.
- The high voltage system may remain powered for up to 1 minute after the vehicle is shut off.
- The SRS system (airbags, etc.) may remain powered for up to 1 minute after disabling.
- Lack of engine noise does not mean vehicle is OFF. Silent movement or instant restart capability exists until vehicle is fully shut down.

SATURN

SATURN

AURA

HEV



2007-09

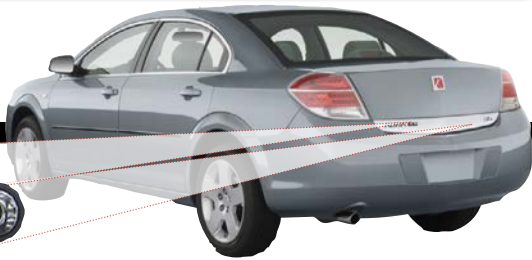

SATURN AURA

(continued) **EXTRICATION INFORMATION**

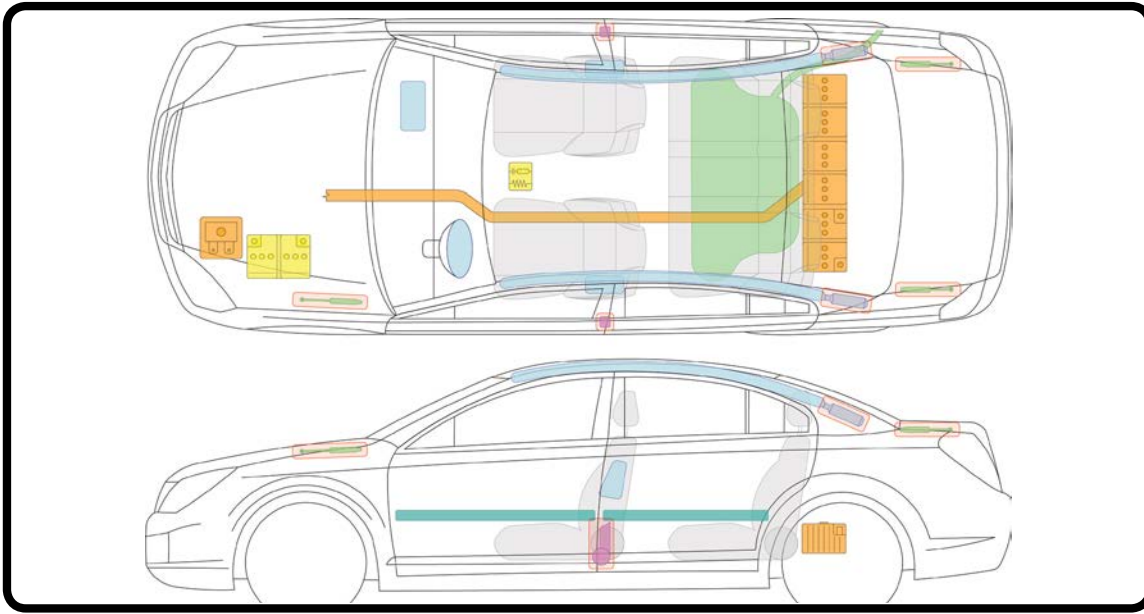

LEGEND		
Airbag	Bodywork Reinforcements	SRS Control Unit
Stored Gas Inflator	Support Cylinder for Hood	12V Battery
Seatbelt Tensioner or Pretensioner	Fuel Tank	High-Voltage Power Cable
High-Voltage Battery	Emergency Disconnect (Remove Fuse)	

DO NOT cut the vehicle until all of the electrical systems have been deactivated and isolated. Cutting prior to disconnecting and isolating the electrical energy sources may cause an electrical arc and/or personal injury.

**MEDIUM VOLTAGE
MANUAL DISCONNECT DETAIL**

For towing and post-incident instructions, see the **POST-INCIDENT** section on page 20.

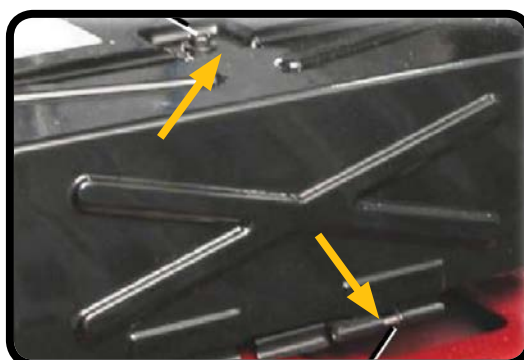

A 10 mm hex bolt secures the module. Hinges are attached to the battery cover.

SATURN



2007-10



SATURN

SATURN

VEHICLE INFORMATION

IMMOBILIZE VEHICLE

- 1. **Chock the wheels.**
- 2. **Set parking brake.**
(foot pedal)
- 3. **Place vehicle into park.**
(center console)

DISABLE VEHICLE

Determine if vehicle is ON. If tachometer needle points to AUTO STOP, then vehicle is ON.

PRIMARY PROCEDURE

- 1. If ON, turn ignition off (key, right of steering column). Remove key.
- 2. Disconnect or cut BOTH 12V negative battery cables (engine compartment).
- 3. Verify tachometer is pointing to OFF.

ALTERNATE PROCEDURE

(if ignition is inaccessible)

- 1. Remove 30A ignition maxi fuse (green) located in underhood fuse box.
- 2. Disconnect/cut BOTH 12V negative battery cables.
- 3. Verify tachometer points to OFF.



30A Ignition Maxi Fuse

HIGH VOLTAGE (HV) MANUAL DISCONNECT

Opening the hinged cover of the manual disconnect causes a spring-loaded disconnect switch to interrupt electrical flow from the medium voltage battery and quickly discharge stored electrical energy in the generator control module. (See next page for detail diagram.)



Cut here to disable BOTH 12V negative cables at the same time.

WARNINGS

- NEVER cut, breach, or touch high voltage components or cabling. Doing so could result in serious injury or death.
- Wait a minimum of 10 seconds after disabling to allow undeployed airbag reserve energy to dissipate.
- This vehicle is a MEDIUM voltage hybrid. The 36V system is indicated by blue cables. Treat blue cables as if they were orange high voltage cables. The 36V system has a much higher arc potential than a 12V.
- Lack of engine noise does not mean vehicle is OFF. Silent movement or instant restart capability exists until vehicle is fully shut down.

VIEW



2007-10



VUE

SATURN

SATURN

(continued)

VEHICLE INFORMATION

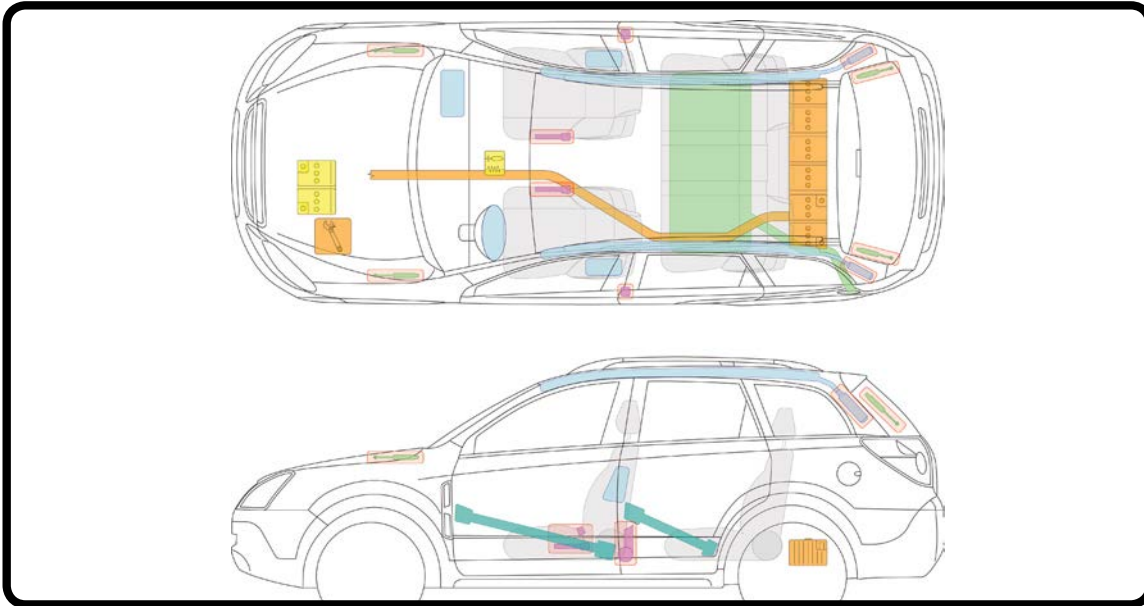

LEGEND		
Airbag	Bodywork Reinforcements	SRS Control Unit
Stored Gas Inflator	Support Cylinder for Hood	12V Battery
Seatbelt Tensioner or Pretensioner	Fuel Tank	High-Voltage Power Cable
High-Voltage Battery	Emergency Disconnect (Unscrew Connector)	

HIGH VOLTAGE (HV) MANUAL DISCONNECT DETAIL

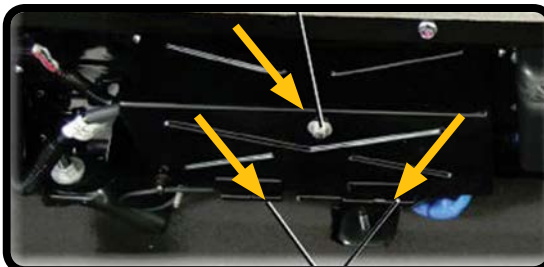

A 10 mm hex bolt secures the module. Hinges attached to the battery hold the cover in place.

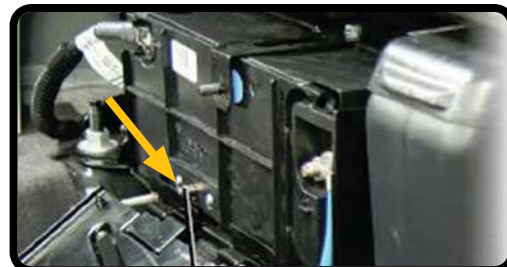

Disconnect Switch (shown with cover open)

For towing and post-incident instructions, see the **POST-INCIDENT** section on page 20.



2013



VEHICLE INFORMATION

IMMOBILIZE VEHICLE

1. **Chock the wheels.**
2. **Set parking brake.**
(hand brake, center console)
3. **Place vehicle into park.**
(center console)

DISABLE VEHICLE

Determine if vehicle is ON by illumination of READY light.

If the charge cable assembly is connected, push the lock release button on the top of the connector and remove (if a quick charge plug does not have a release button pull to remove).

PRIMARY PROCEDURE

1. If ON, shut off ignition (push-button, right of instrument panel). Remove proximity key and keep it at least 16 feet (5 meters) from vehicle.
2. Disconnect 12V battery (engine compartment, drivers side).

ALTERNATE PROCEDURE

(if power button is inaccessible)

1. Remove under the hood fuse box cover (driver's side).
2. Remove IG2 fuse (10A red) from the engine compartment fuse box. If the correct fuse cannot be identified, pull all of the fuses in fuse box.
3. Disconnect 12V auxiliary battery (engine compartment, drivers side)

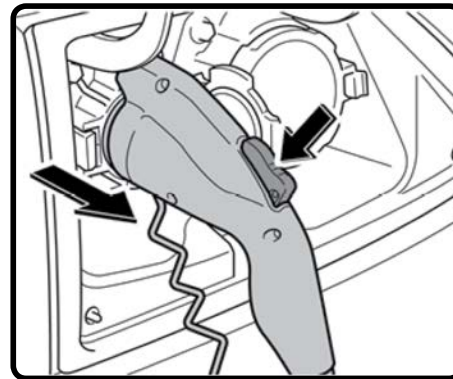



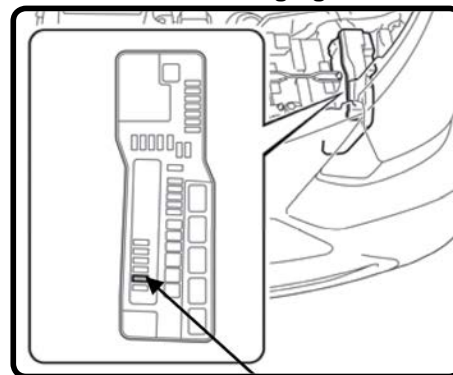

Disconnect Charging Cable



Remove Fuse IG2 (10A red)

WARNINGS

-  NEVER cut, breach, or touch high voltage components or cabling. Doing so could result in serious injury or death.
-  The high voltage system may remain powered for up to 10 minutes after shutoff/disabling. Avoid touching, cutting, or opening any orange high voltage cable or component.
-  Airbags and SRS may remain powered for up to 90 seconds after shutoff/disabling. Avoid breaching SRS components.
-  In the event of a fire involving a charging station, reference the **FIRE** portion of this guide, and treat it as an energized electrical fire until power to the charger can be shut down.
-  This vehicle does not have an internal combustion engine. Lack of engine noise does not mean vehicle is OFF. Silent movement capability exists until vehicle is fully shut down.

SCION

SCION











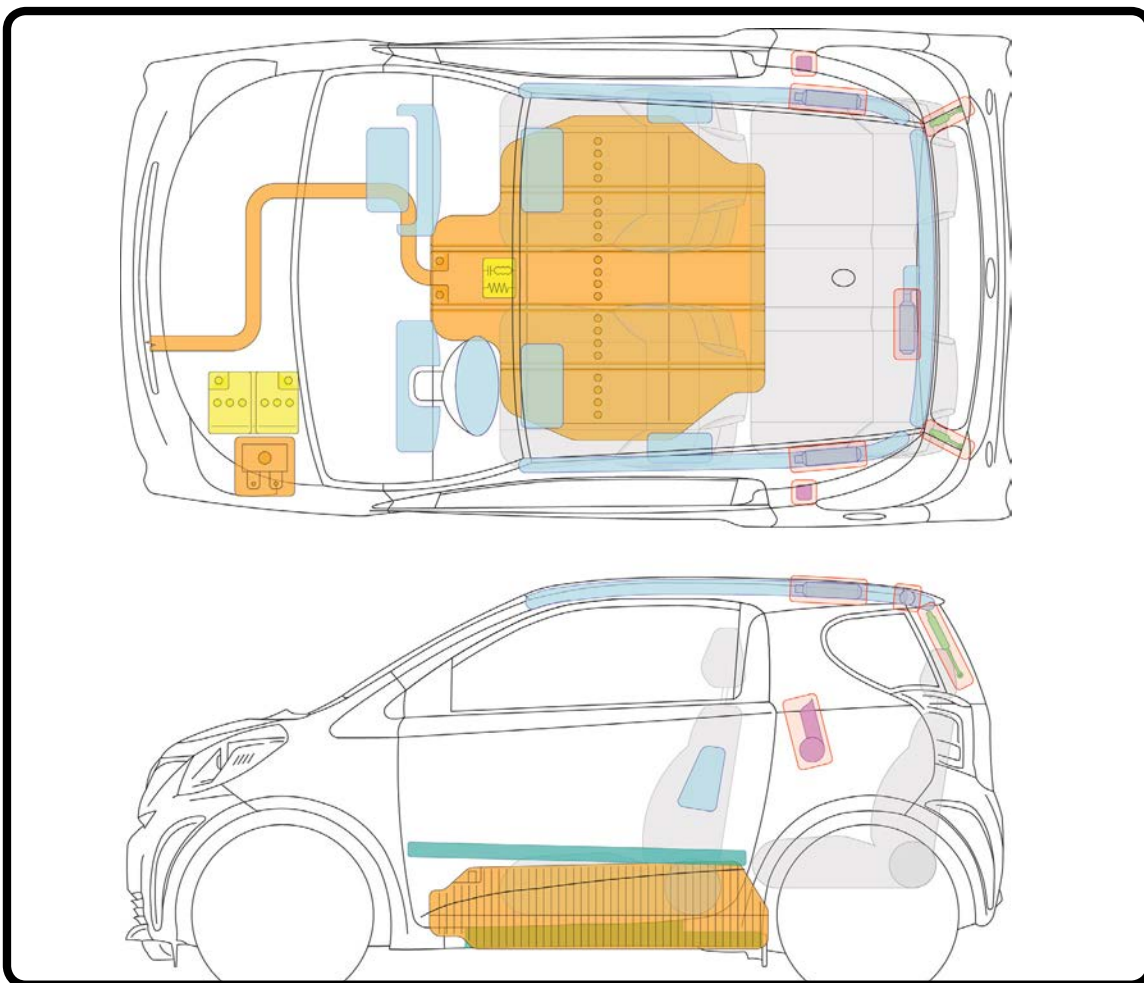



2013

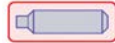

(continued) **EXTRICATION INFORMATION**



LEGEND		
 Airbag	 Bodywork Reinforcements	 SRS Control Unit
 Stored Gas Inflator	 Support Cylinder for Hood	 12V Battery
 Seatbelt Tensioner or Pretensioner		 High-Voltage Power Cable
 High-Voltage Battery	 Emergency Disconnect (Remove Fuse)	

For towing and post-incident instructions, see the **POST-INCIDENT** section on page 20.

SCION iQ EV



2011



Smart

fortwo electric drive

SMART

VEHICLE INFORMATION

IMMOBILIZE VEHICLE

1. **Chock the wheels.**
2. **Set parking brake.**
(hand brake, center console)
3. **Place vehicle into park.**
(center console, gear selector)

DISABLE VEHICLE

Determine if vehicle is ON by presence of READY indicator.

PRIMARY PROCEDURE

1. If ON, turn off ignition and remove key (key, center console).
2. Disconnect 12V battery (passenger footwell).

NOTE: Either of the above steps individually should disable the HV system.

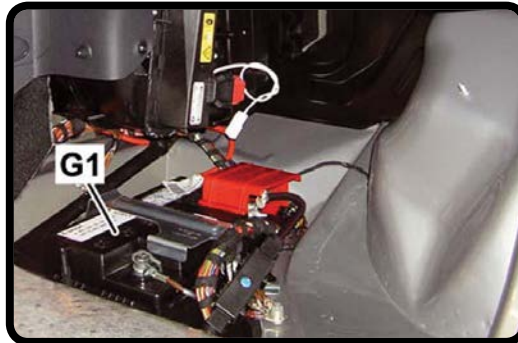

12V Battery Location

ALTERNATE PROCEDURE



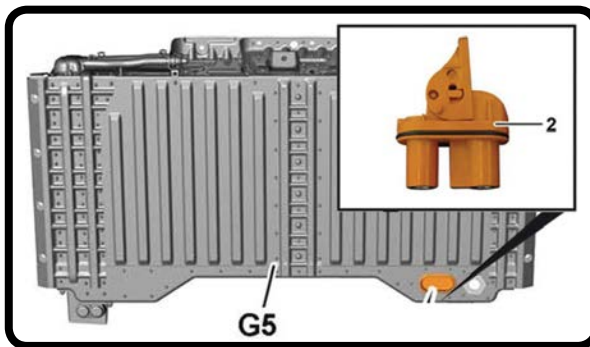

NOTE: In order to remove the HV Service Disconnect Plug, you must wear insulated electrical gloves.

1. If ON, turn off ignition and remove key (key, center console).
2. Remove cap of Service Disconnect plug (left underside of HV battery).
3. Remove Service Disconnect. (orange)



Service Disconnect Plug

WARNINGS

-  NEVER cut, breach, or touch high voltage components or cabling. Doing so could result in serious injury or death.
-  Insulating gloves as per DIN VDE 0680 or EN 60903 must be worn when unplugging the Service Disconnect plug on the HV battery.
-  In the event of a fire involving a charging station, reference the **FIRE** portion of this guide, and treat it as an energized electrical fire until power to the charger can be shut down.
-  This vehicle does not have an internal combustion engine. Lack of engine noise does not mean vehicle is OFF. Silent movement capability exists until vehicle is fully shut down.



2011







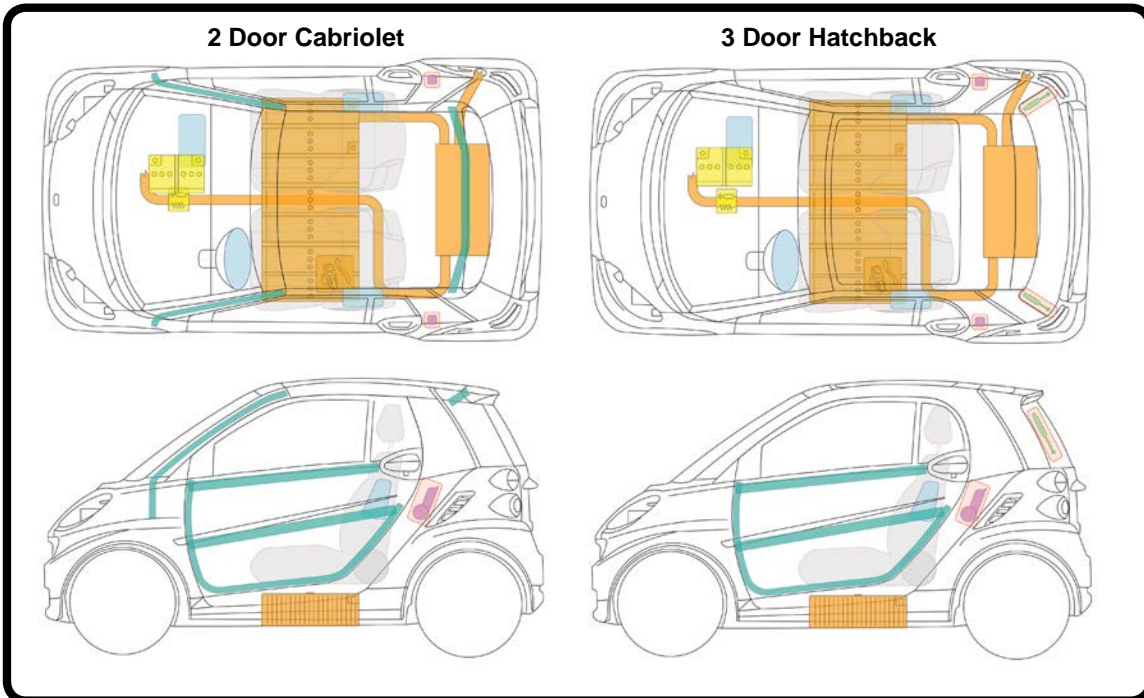

electric drive

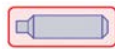

fortwo electric drive

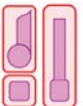
(continued) **EXTRICATION INFORMATION**

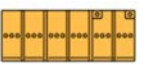

LEGEND		
 Airbag	 Bodywork Reinforcements	 SRS Control Unit
 Stored Gas Inflator	 Support Cylinder for Hood	 12V Battery
 Seatbelt Tensioner or Pretensioner		 High-Voltage Power Cable
 High-Voltage Battery	 Emergency Disconnect (Remove Plug)	

For towing and post-incident instructions, see the **POST-INCIDENT** section on page 20.

SMART

smart



2006-12





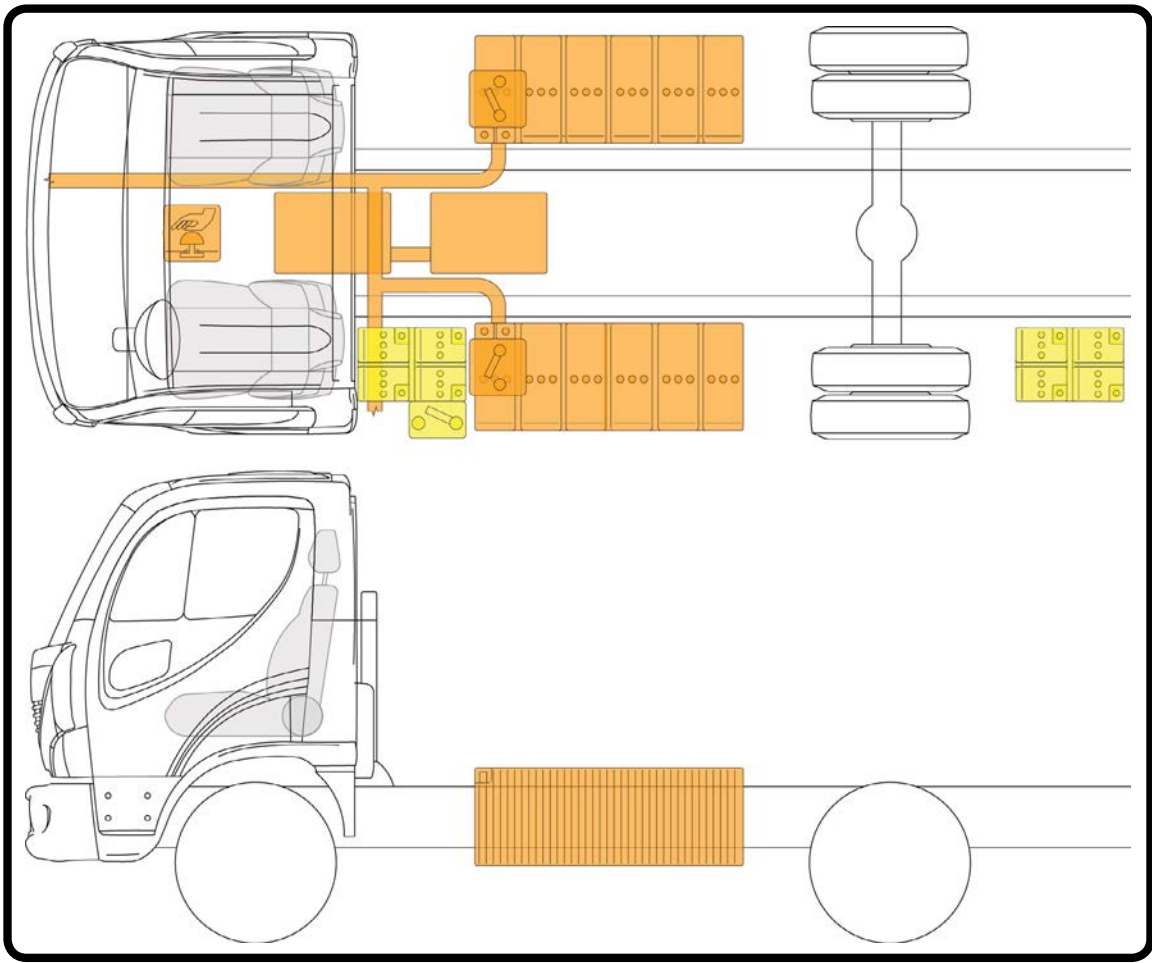

SMITH NEWTON

SMITH

(continued) **EXTRICATION INFORMATION**



LEGEND			
	High-Voltage Battery		12V Battery
	Emergency Disconnect (Switch Off)		High-Voltage Power Cable
	Emergency Shut Down Button		

For towing and post-incident instructions, see the **POST-INCIDENT** section on page 20.



2012-15





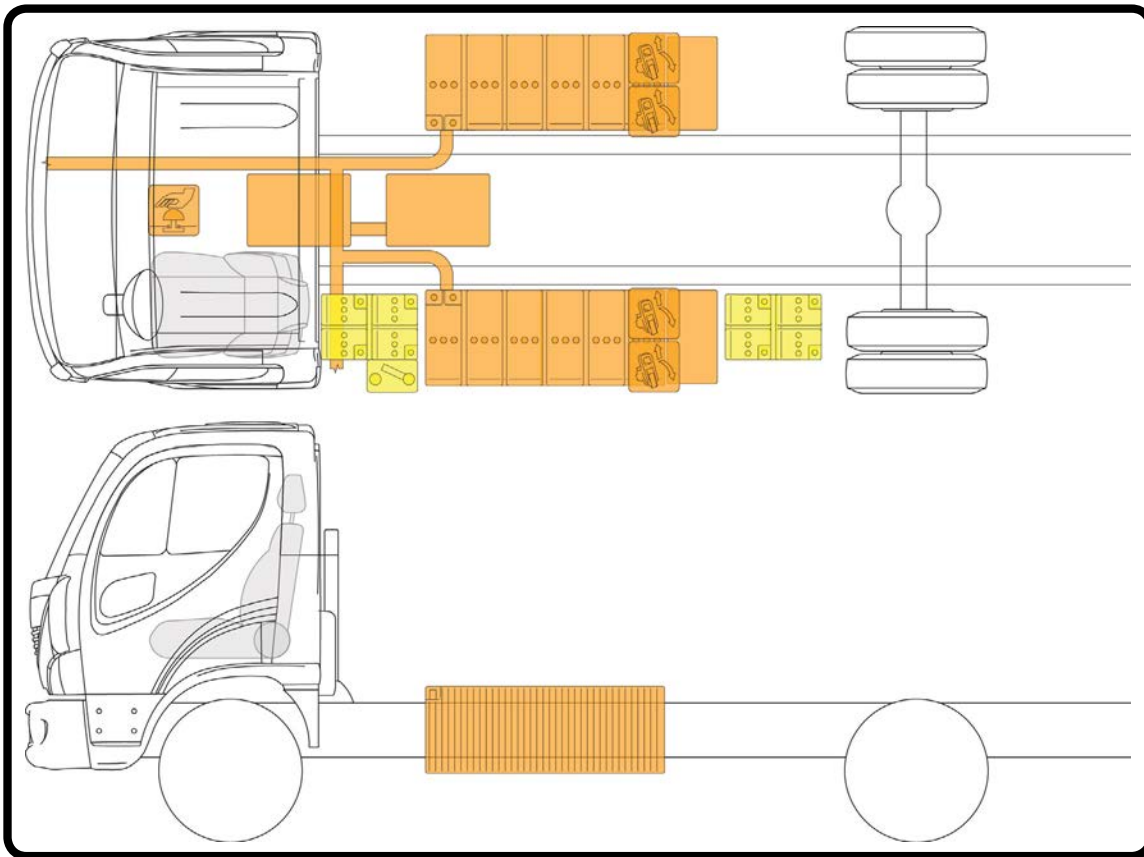

SMITH NEWTON

(continued) **EXTRICATION INFORMATION**

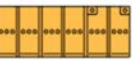

LEGEND

	12V Battery		High-Voltage Battery		High-Voltage Power Cable
	Emergency Disconnect (Remove Plug)		Emergency Disconnect (Switch Off)		Emergency Shut Down Button

For towing and post-incident instructions, see the **POST-INCIDENT** section on page 20.

SMITH



2012-15



SMITH
SMITH NEWTON STEP VAN

VEHICLE INFORMATION

IMMOBILIZE VEHICLE

1. Chock the wheels.
2. Set parking brake.
3. Place vehicle into park.

DISABLE VEHICLE

PRIMARY PROCEDURE

1. If ON, turn the ignition key to the OFF position and remove key.
2. Turn the 24V isolator switch (under hood, passenger's side) to the ISOLATED (vertical) position (it can be accessed without lifting the hood by reaching past the right front tire).
3. On either side of the vehicle (in front of the rear wheels) locate the access door for the Master Service Disconnects (MSD) and lower it. Locate the two orange MSD plugs (two per side).
4. Disconnect MSD's by:
 - Push the small black tab down while pulling the locking lever up.
 - Depress the small black tab once more and continue to pull the locking lever to the 90° position.
 - Pull the MSD's free and secure them for later reinstallation.
5. Repeat this process until all four (4) MSD plugs are removed.

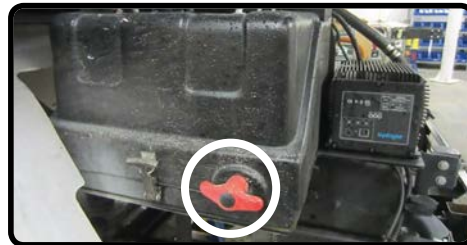

24V System Isolator



Access Door and MSD's



Depress Small Black Tab



Secondary Catch at 45°



Locking Lever at 90°

WARNINGS



NEVER cut, breach, or touch orange high voltage components or cabling. Doing so could result in serious injury or death.



This vehicle does not have an internal combustion engine. Lack of engine noise does not mean vehicle is OFF. Silent movement capability exists until vehicle is fully shut down.



2012-15





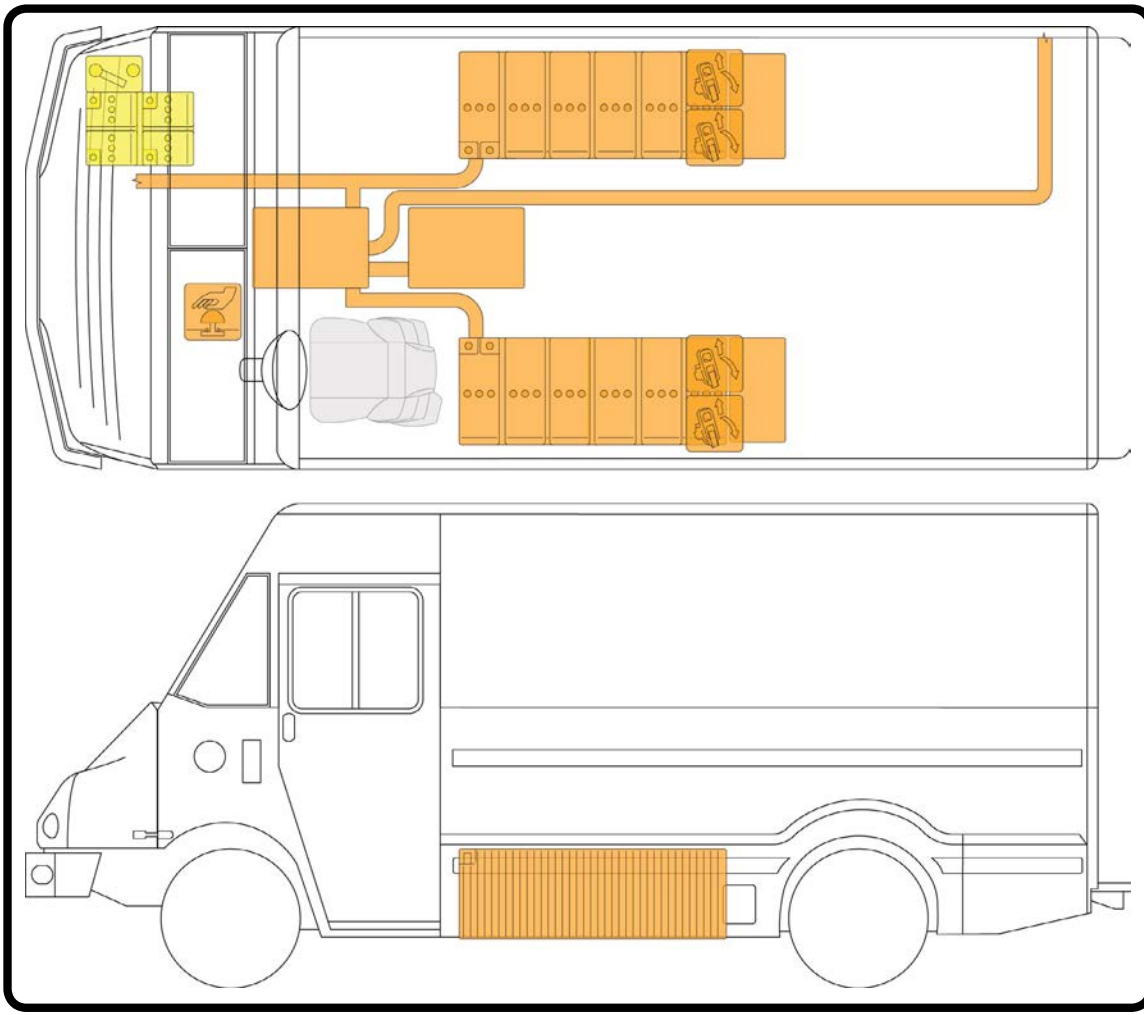

SMITH NEWTON STEP VAN

SMITH

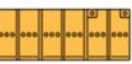
(continued) **EXTRICATION INFORMATION**



LEGEND			
	12V Battery		High-Voltage Battery
	Emergency Disconnect (Remove Plug)		Emergency Disconnect (Switch Off)
	High-Voltage Power Cable		Emergency Shut Down Button

For towing and post-incident instructions, see the **POST-INCIDENT** section on page 20.



2014-15

HYBRID



SUBARU

VEHICLE INFORMATION

IMMOBILIZE VEHICLE

1. Chock the wheels.
2. Set parking brake. (hand brake, center console)
3. Place vehicle into park. (center console, gear selector)

DISABLE VEHICLE

Determine if vehicle is ON by presence of illuminated READY indicator near tachometer.

PRIMARY PROCEDURE

1. If ON, turn off ignition and remove key or if equipped push the Start/Stop button ignition switch once (steering column). Remove proximity key and keep it at least 16 feet (5 meters) from vehicle.
2. Disconnect negative cables for both 12V batteries (engine compartment).

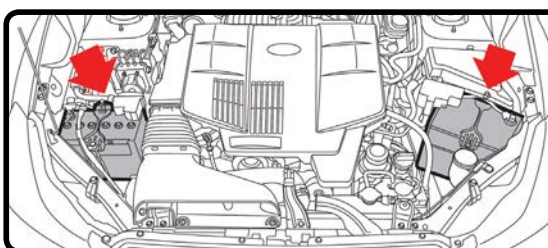

12V Restart and Auxiliary Battery

ALTERNATE PROCEDURE #1

1. Remove the SBF No.14 fuse (30 A) (engine compartment fuse box). If the correct fuse cannot be recognized, pull all the fuses.
2. Disconnect negative cables for both 12V batteries (engine compartment).

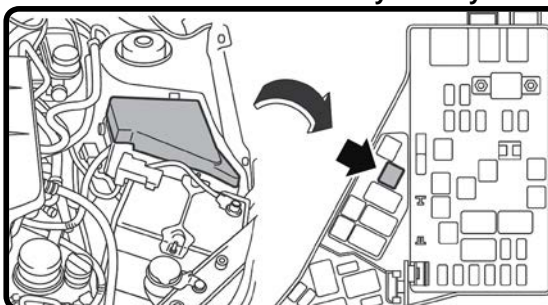

Remove SBF No.14 fuse (30 A)

ALTERNATE PROCEDURE #2

1. Locate and remove the service disconnect plug (cargo area).

NOTE: Service Disconnect Plug details are located on next page

2. Disconnect negative cables for both 12V batteries (engine compartment).

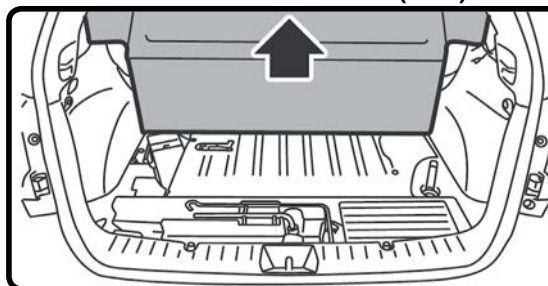

Service Disconnect Plug in Cargo Area

WARNINGS

- NEVER cut, breach, or touch high voltage components or cabling. Doing so could result in serious injury or death.
- The high voltage system may remain powered for up to 10 minutes after shutoff/disabling. Avoid touching, cutting, or opening any orange high voltage cable or component.
- Airbags and SRS may remain powered for up to 60 seconds after shutoff/disabling. Avoid breaching SRS components.
- This vehicle does not have an internal combustion engine. Lack of engine noise does not mean vehicle is OFF. Silent movement capability exists until vehicle is fully shut down.

SUBARU XV CROSS TREK

HEV

SUBARU



2014-15

HYBRID



SUBARU XV CROSSSTREK

(continued) EXTRICATION INFORMATION

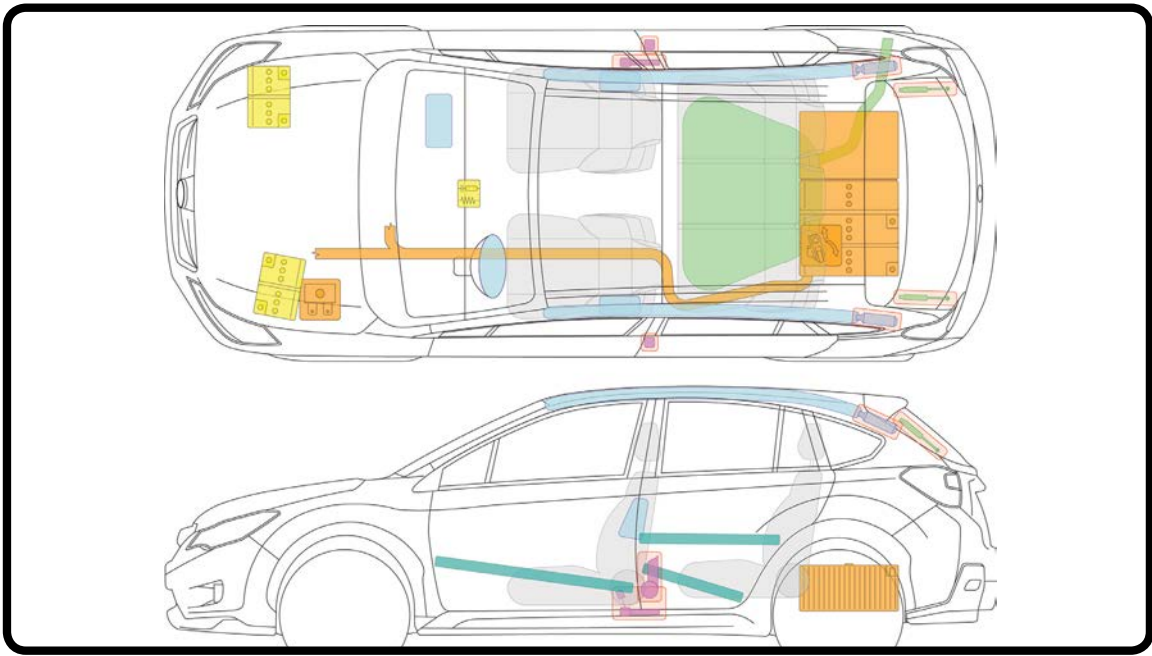

LEGEND		
	Airbag	
	Stored Gas Inflator	
	Seatbelt Tensioner or Pretensioner	
	High-Voltage Battery	
	Bodywork Reinforcements	
	Support Cylinder for Hood	

SERVICE DISCONNECT PLUG (DETAIL)

1. Pull lever up until it hits the stopper.
2. Raise the lever while pushing the lock (A). The lever is locked in place.
3. Pull the service disconnect plug out from the high voltage battery.

NOTE: Wear insulated rubber gloves for this process.

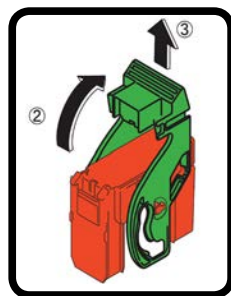
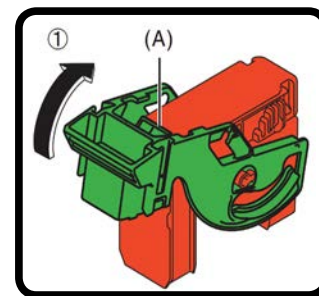

For towing and post-incident instructions, see the **POST-INCIDENT** section on page 20.



2017-18



VEHICLE INFORMATION

Li-ion

See pages 15, 22.

IMMOBILIZE VEHICLE

1. **Chock the wheels.**
2. **Set parking brake.**
(push-button on the end of the gearshift)
3. **Place vehicle into park.**
(completed in step 2)

DISABLE VEHICLE

PRIMARY PROCEDURE

1. Open the hood:
 - 12V enabled: Touch the associated OPEN button on the dash touchscreen.
 - 12V disabled: Release the tow eye cover from front bumper, pull two wires out, then connect 12V power to terminals.
2. Remove the access panel by pulling it up to release the clips securing it.
3. Double cut the first responder loop to remove an entire section (engine compartment, driver's side).



Set Parking Brake and Place into Park

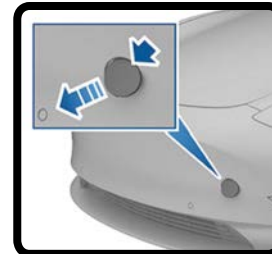

Front Bumper Tow Eye Cover



Front Bumper Hood Release Terminals

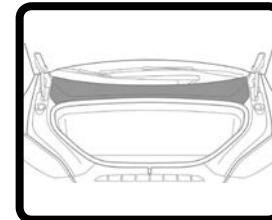

Remove Access Panel Under Hood

ALTERNATE PROCEDURE (Only if hood is inaccessible)

1. Use a saw or rescue tool and cut 6 inches (15 cm) through the rear pillar, under passenger's rear fixed glass.

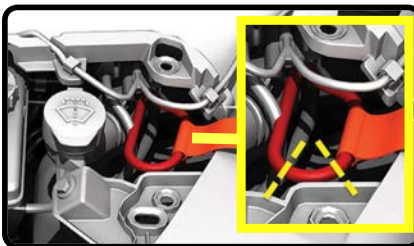

Double Cut First Responder Loop



Rear Pillar Cut Loop

WARNINGS

- NEVER cut, breach, or touch high voltage components or cabling. Doing so could result in serious injury or death.
- High voltage cables and components may remain energized for up to 2 minutes after disabling.
- Airbags and SRS may remain powered for up to 10 seconds after disabling.
- In the event of a fire involving a charging station, reference the **FIRE** portion of this guide, and treat it as an energized electrical fire until power to the charger can be shut down.
- This vehicle does not have an internal combustion engine. Lack of engine noise does not mean vehicle is OFF. Silent movement capability exists until vehicle is fully shut down.

TESLA
MODEL S



2017-18

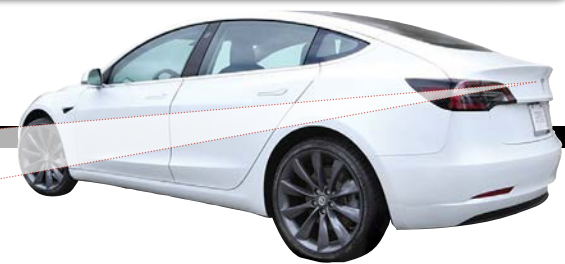

TESLA
MODEL S

Li-ion (continued) **EXTRICATION INFORMATION**

See pages 15, 22.

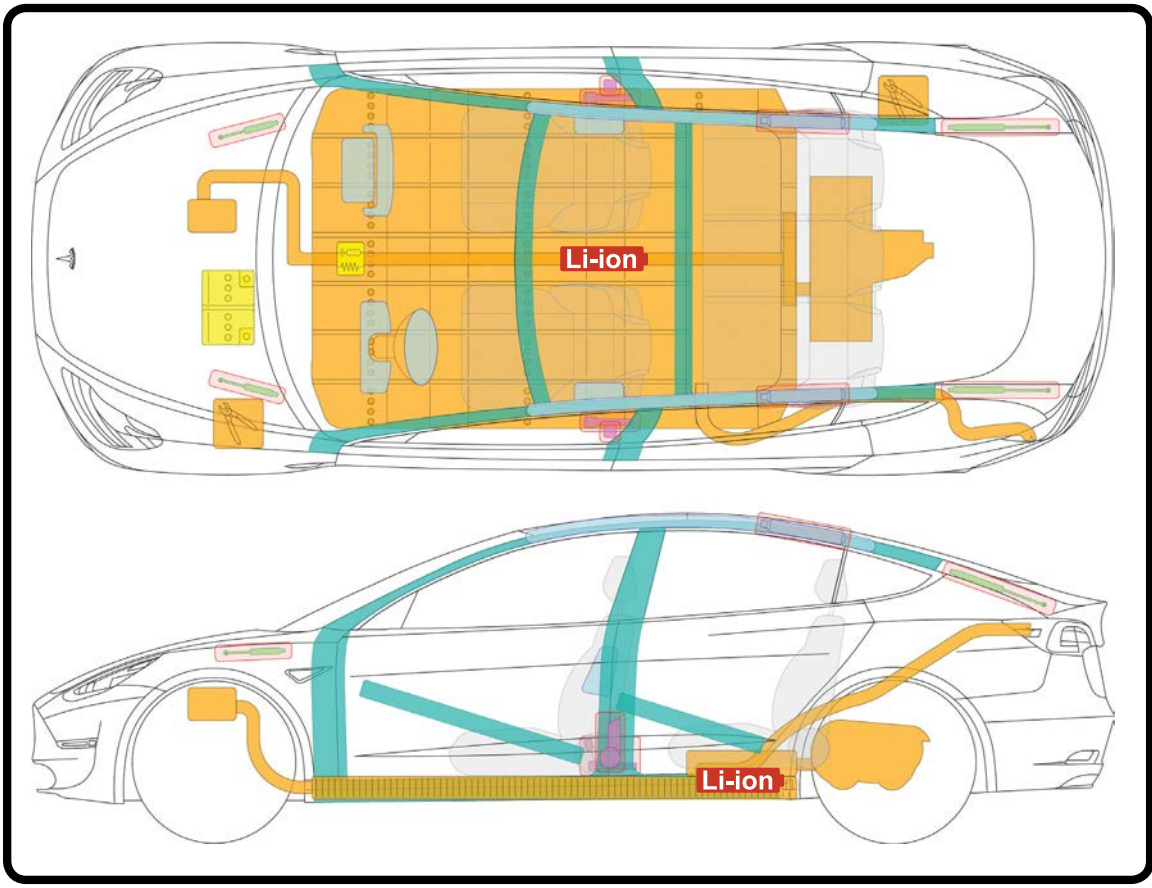

LEGEND		
Airbag	Bodywork Reinforcements	SRS Control Unit
Stored Gas Inflator	Support Cylinder for Hood	12V Battery
Seatbelt Tensioner or Pretensioner		High-Voltage Power Cable
High-Voltage Battery	Emergency Disconnect (Cut Cable)	

For towing and post-incident instructions, see the **POST-INCIDENT** section on page 20.



2012-15



Li-ion
See pages 15, 22.

VEHICLE INFORMATION

IMMOBILIZE VEHICLE

1. **Chock the wheels.**
2. **Set parking brake.**
(push-button on the end of the gearshift)
3. **Place vehicle into park.**
(completed in step 2)

DISABLE VEHICLE

PRIMARY PROCEDURE

1. Open the hood (front trunk): double-click Tesla logo on key fob **OR** Touch FRONT TRUNK on the touchscreen.
 - To open the front trunk manually: pull the release handle located under the glove box, then push down on the secondary catch lever. To release pressure against the secondary catch, you may need to push the hood down.
2. Remove the access panel by pulling its rear edge upward.
3. Double cut the first responder cut loop (passenger side) to remove an entire section.



Parking Brake & Park



Double-Click Tesla Logo



Glove Box Hood Release



Secondary Hood Catch

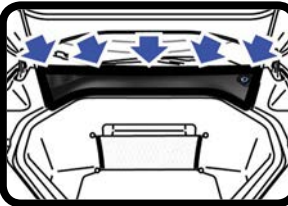

Remove Access Panel



Double Cut Loop

ALTERNATE PROCEDURE (if cut loop is inaccessible)

1. Use a saw or rescue tool and cut 6 inches (15 cm) through the label and into the rear driver's side door pillar. **NOTE:** *This is on vehicles built after June 2013.*



Cut Through Label

WARNINGS

- NEVER cut, breach, or touch high voltage components or cabling. Doing so could result in serious injury or death.
- High voltage cables and components may remain energized for up to 2 minutes after disabling.
- Airbags and SRS may remain powered for up to 1 minute after disabling.
- In the event of a fire involving a charging station, reference the **FIRE** portion of this guide, and treat it as an energized electrical fire until power to the charger can be shut down.
- This vehicle does not have an internal combustion engine. Lack of engine noise does not mean vehicle is OFF. Silent movement capability exists until vehicle is fully shut down.

TESLA MODEL S



2012-15

TESLA









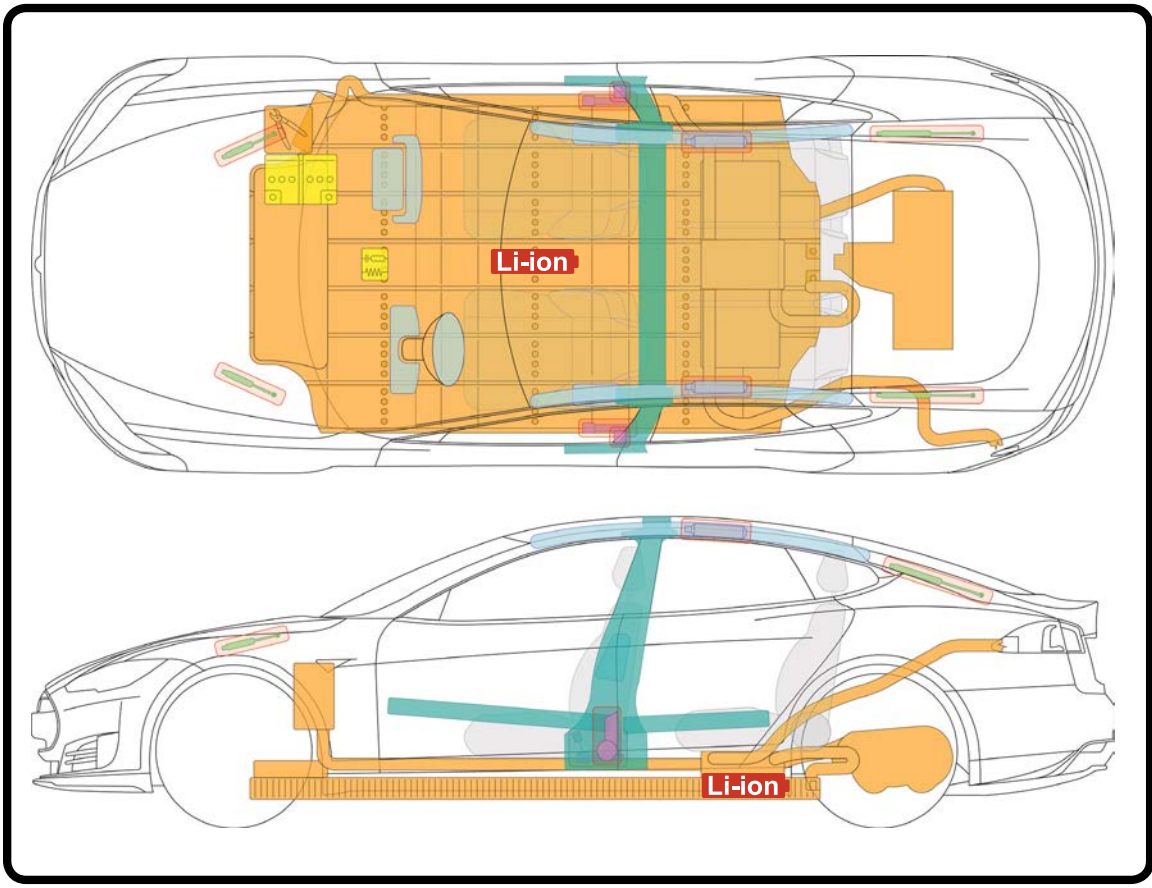



TESLA MODEL S

Li-ion (continued) **EXTRICATION INFORMATION**

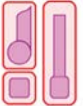
See pages 15, 22.



LEGEND		
 Airbag	 Bodywork Reinforcements	 SRS Control Unit
 Stored Gas Inflator	 Support Cylinder for Hood	 12V Battery
 Seatbelt Tensioner or Pretensioner		 High-Voltage Power Cable
 High-Voltage Battery	 Emergency Disconnect (Cut Cable)	

For towing and post-incident instructions, see the **POST-INCIDENT** section on page 20.



2016-18



VEHICLE INFORMATION

Li-ion

See pages 15, 22.

IMMOBILIZE VEHICLE

1. **Chock the wheels.**
2. **Set parking brake.**
(push-button on the end of the gearshift)
3. **Place vehicle into park.**
(completed in step 2)

DISABLE VEHICLE

PRIMARY PROCEDURE

1. Open the hood (front trunk): double-click Tesla logo on key fob **OR** Touch CONTROLS > FRONT TRUNK on the touchscreen.
 - To open the front trunk manually: pull the release cables located in both front wheel arch liners. First pull the strap labeled (A) near the right wheel then, (B) near the left wheel.
2. Remove the access panel by pulling its rear edge upward.
3. Double cut the first responder cut loop (passenger side) to remove an entire section.

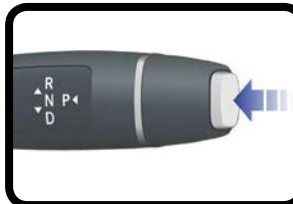

Parking Brake & Park



Double-Click Tesla Logo

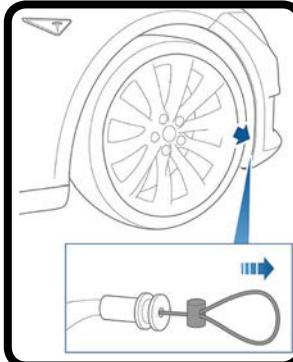

Strap A - Right Wheel

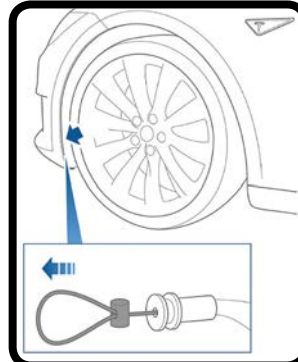

Strap B - Left Wheel

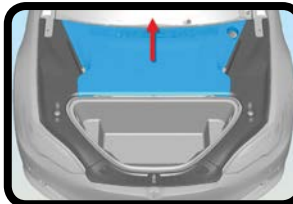

Remove Access Panel



Double Cut Loop

WARNINGS

- NEVER cut, breach, or touch high voltage components or cabling. Doing so could result in serious injury or death.
- High voltage cables and components may remain energized for up to 2 minutes after disabling.
- Airbags and SRS may remain powered for up to 10 seconds after disabling.
- In the event of a fire involving a charging station, reference the **FIRE** portion of this guide, and treat it as an energized electrical fire until power to the charger can be shut down.
- This vehicle does not have an internal combustion engine. Lack of engine noise does not mean vehicle is OFF. Silent movement capability exists until vehicle is fully shut down.

TESLA
MODEL S



2016-18

TESLA









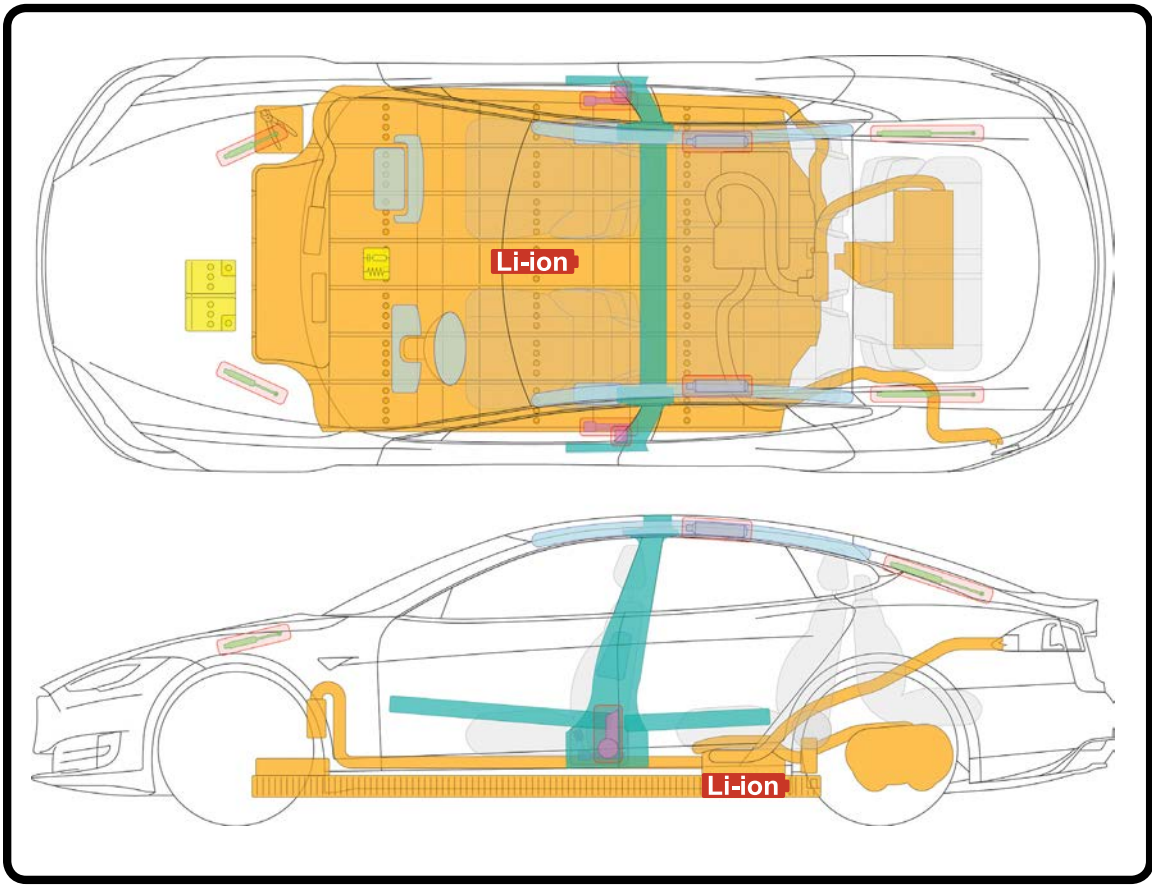



TESLA MODEL S

Li-ion (continued) **EXTRICATION INFORMATION**

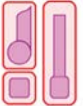
See pages 15, 22.



LEGEND		
 Airbag	 Bodywork Reinforcements	 SRS Control Unit
 Stored Gas Inflator	 Support Cylinder for Hood	 12V Battery
 Seatbelt Tensioner or Pretensioner		 High-Voltage Power Cable
 High-Voltage Battery	 Emergency Disconnect (Cut Cable)	

For towing and post-incident instructions, see the **POST-INCIDENT** section on page 20.



2014-15



VEHICLE INFORMATION

Li-ion

See pages 15, 22.

IMMOBILIZE VEHICLE

1. **Chock the wheels.**
2. **Set parking brake.**
(push-button on the end of the gearshift)
3. **Place vehicle into park.**
(completed in step 2)

DISABLE VEHICLE

PRIMARY PROCEDURE

1. Open the hood (front trunk): double-click Tesla logo on key fob.
 - To open the front trunk manually: pry the nose cone forward, pull the primary release lever (under the front middle of the hood to the left), push the secondary release lever (under the front middle of the hood) and push up on the hood.

2. Remove the access panel by pulling its rear edge upward.
3. Double cut the first responder cut loop (passenger side) to remove an entire section.

ALTERNATE PROCEDURE

(if cut loop is inaccessible)

1. Use a saw or rescue tool and cut 6 inches (15 cm) through the label and into the rear driver's side door pillar.



Parking Brake & Park



Double-Click Tesla Logo



Pry Forward Nose Cone

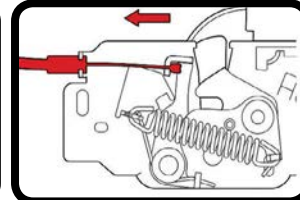

Primary Hood Release

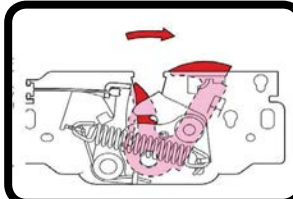

Secondary Hood Release

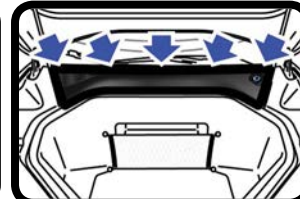

Remove Access Panel



Double Cut Loop



Cut Through Label

WARNINGS

- NEVER cut, breach, or touch high voltage components or cabling. Doing so could result in serious injury or death.
- High voltage cables and components may remain energized for up to 2 minutes after disabling.
- Airbags and SRS may remain powered for up to 10 seconds after disabling.
- In the event of a fire involving a charging station, reference the **FIRE** portion of this guide, and treat it as an energized electrical fire until power to the charger can be shut down.
- This vehicle does not have an internal combustion engine. Lack of engine noise does not mean vehicle is OFF. Silent movement capability exists until vehicle is fully shut down.

TESLA MODEL S DUAL MOTOR

EV



2014-15

TESLA









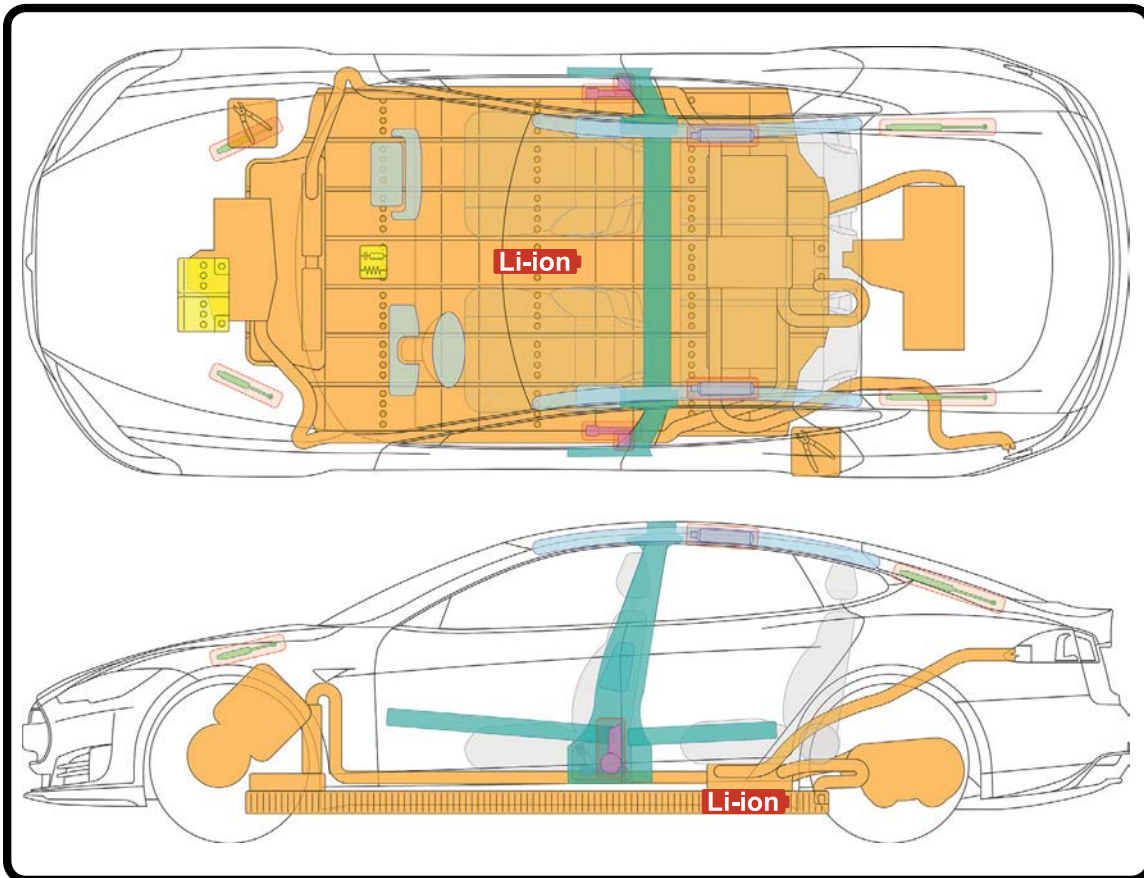

TESLA DUAL MOTOR MODEL S

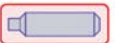
Li-ion (continued) **EXTRICATION INFORMATION**

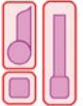
See pages 15, 22.



LEGEND		
 Airbag	 Bodywork Reinforcements	 SRS Control Unit
 Stored Gas Inflator	 Support Cylinder for Hood	 12V Battery
 Seatbelt Tensioner or Pretensioner		 High-Voltage Power Cable
 High-Voltage Battery	 Emergency Disconnect (Cut Cable)	

For towing and post-incident instructions, see the **POST-INCIDENT** section on page 20.

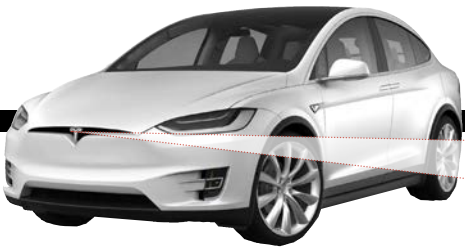

2016-18



VEHICLE INFORMATION

Li-ion

See pages 15, 22.

IMMOBILIZE VEHICLE

1. **Chock the wheels.**
2. **Set parking brake.**
(push-button on the end of the gearshift)
3. **Place vehicle into park.**
(completed in step 2)

DISABLE VEHICLE

PRIMARY PROCEDURE

1. Open the hood:
 - Touch CONTROLS > DOORS > FRONT TRUNK on the dash touchscreen.
 - **OR** Double-click the front key button.
 - **OR** Release the tow hook cover on the front bumper, and then pull both straps, labeled A and B, in alphabetical order.
2. Remove the access panel by pulling it up to release the clips securing it.
3. Double cut the first responder loop to remove an entire section.

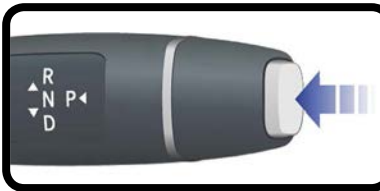

Set Parking Brake and Place into Park

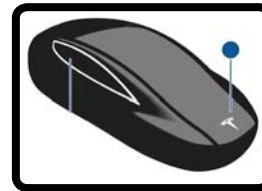

Open Hood Front Key Button

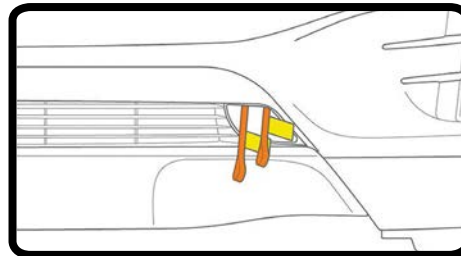

Front Trunk Release Straps

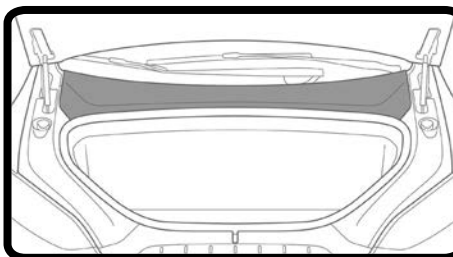

Remove Access Panel



Cut Loop Under Cowl

WARNINGS

- NEVER cut, breach, or touch high voltage components or cabling. Doing so could result in serious injury or death.
- High voltage cables and components may remain energized for up to 2 minutes after disabling.
- Airbags and SRS may remain powered for up to 10 seconds after disabling.
- In the event of a fire involving a charging station, reference the **FIRE** portion of this guide, and treat it as an energized electrical fire until power to the charger can be shut down.
- This vehicle does not have an internal combustion engine. Lack of engine noise does not mean vehicle is OFF. Silent movement capability exists until vehicle is fully shut down.

TESLA MODEL X



2016-18









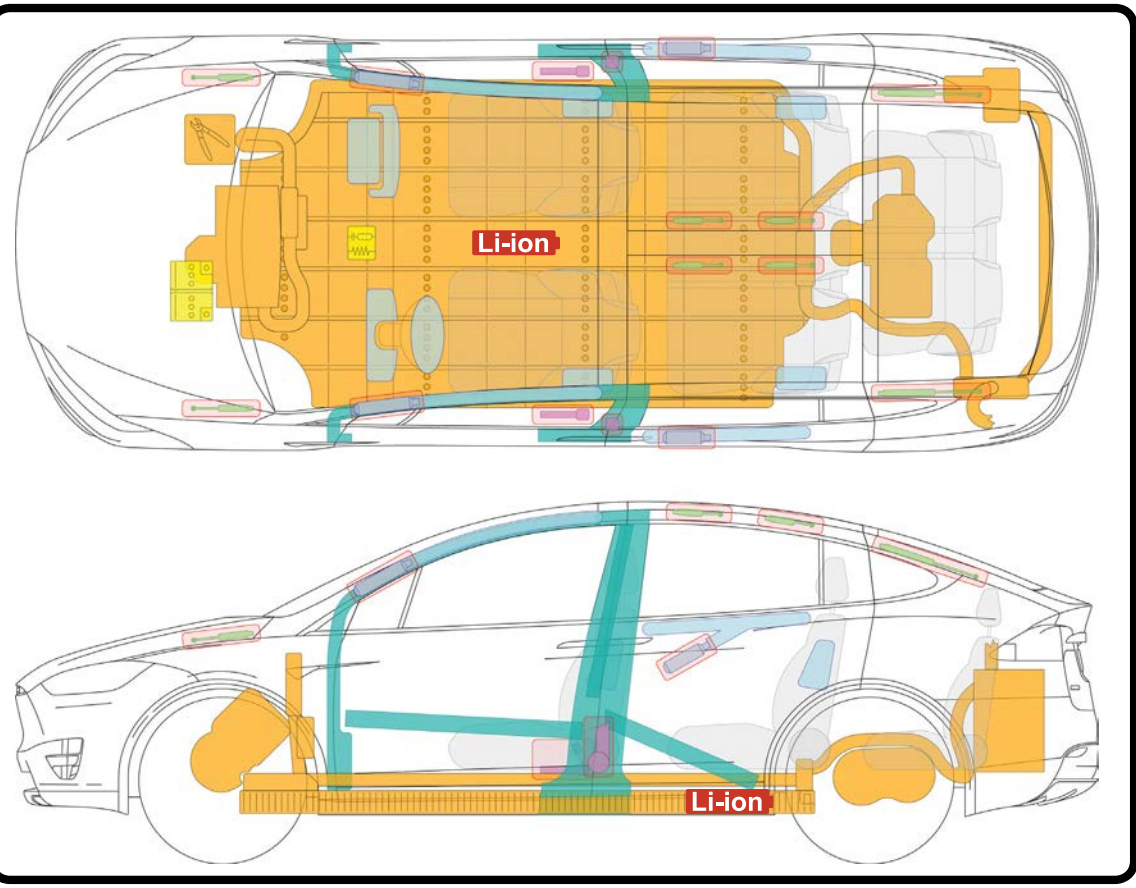

TESLA

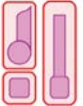

TESLA MODEL X

Li-ion (continued) **EXTRICATION INFORMATION**



LEGEND		
 Airbag	 Bodywork Reinforcements	 SRS Control Unit
 Stored Gas Inflator	 Support Cylinder for Hood	 12V Battery
 Seatbelt Tensioner or Pretensioner		 High-Voltage Power Cable
 High-Voltage Battery	 Emergency Disconnect (Cut Cable)	

For towing and post-incident instructions, see the **POST-INCIDENT** section on page 20.



2008-09



VEHICLE INFORMATION

Li-ion

See pages 15, 22.

IMMOBILIZE VEHICLE

1. **Chock the wheels.**
2. **Set parking brake.**
(center console)
3. **Place vehicle in neutral.**
(gear lever, center console)

DISABLE VEHICLE

Determine if vehicle is ON by illumination of digital displays.

PRIMARY PROCEDURE

1. If ON, turn off ignition (steering column).
Remove key.
2. Raise trunk by pressing the release button (next to the headlight switch).
3. Remove the yellow cut loop cover and double cut the SRS / HV Disable Loop cable (right side of the power electronics module). If you do not find it there, refer to the 2010-2011 Roadster entry.

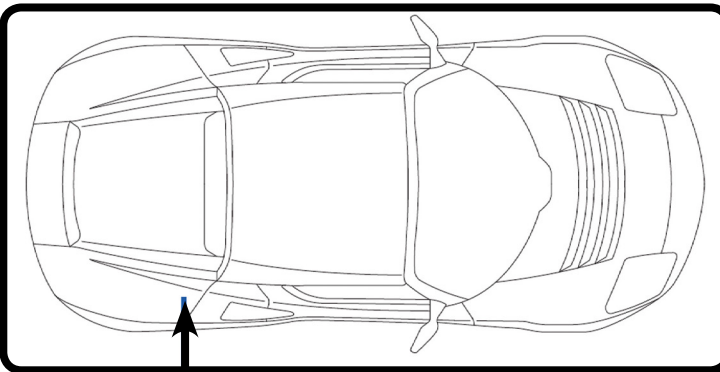

12V Disconnect



Remove Yellow Cover



Cut SRS / HV Disable Loop

WARNINGS

- NEVER cut, breach, or touch high voltage components or cabling. Doing so could result in serious injury or death.
- High voltage cables and components may remain energized for up to 5 minutes after disabling.
- Airbags and SRS may remain powered for up to 30 seconds after disabling.
- Vehicle body is constructed of carbon fiber. Wear respiratory protection when cutting body panels.
- In the event of a fire involving a charging station, reference the **FIRE** portion of this guide, and treat it as an energized electrical fire until power to the charger can be shut down.
- This vehicle does not have an internal combustion engine. Lack of engine noise does not mean vehicle is OFF. Silent movement capability exists until vehicle is fully shut down.

TESLA
S
L
T

Roadster



2008-09

TESLA











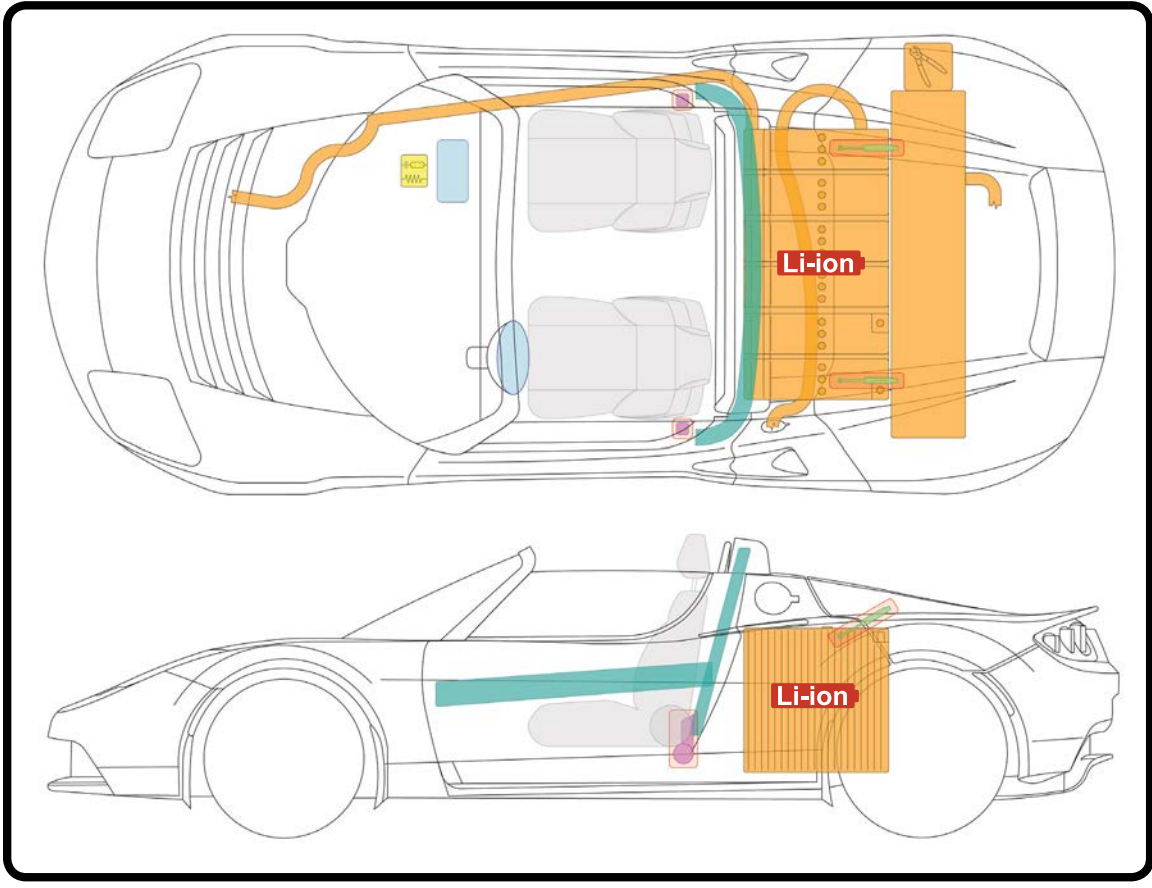

TESLA

Roadster

Li-ion (continued) **EXTRICATION INFORMATION**

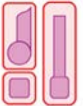
See pages 15, 22.



LEGEND			
 Airbag	 Bodywork Reinforcements	 SRS Control Unit	
 Stored Gas Inflator	 Support Cylinder for Hood	 12V Battery	
 Seatbelt Tensioner or Pretensioner		 High-Voltage Power Cable	
 High-Voltage Battery	 Emergency Disconnect (Cut Cable)		

For towing and post-incident instructions, see the **POST-INCIDENT** section on page 20.

TESLA



2010-13



VEHICLE INFORMATION

Li-ion
See pages 15, 22.

IMMOBILIZE VEHICLE

- 1. Chock the wheels.
- 2. Set parking brake. (center console)
- 3. Place vehicle into park. (push-button or shifter, center console)

DISABLE VEHICLE

Determine if vehicle is ON by illumination of instrument cluster lights.

PRIMARY PROCEDURE

- 1. If ON, turn off ignition (steering column). Remove key.
- 2. Open the hood by pulling the release handle (left of the steering column).
- 3. Double cut the SRS / HV Disable Loop Cable (base of windshield near brake fluid reservoir). If you do not find it there, refer to the 2008 Roadster entry.



Push Button Gears

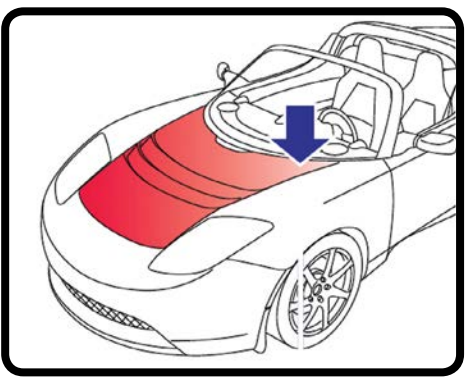

12V Disconnect



Cut SRS / HV Disable Loop Cable

WARNINGS

- NEVER cut, breach, or touch high voltage components or cabling. Doing so could result in serious injury or death.
- High voltage cables and components may remain energized for up to 5 minutes after disabling.
- Airbags and SRS may remain powered for up to 30 seconds after disabling.
- Vehicle body is constructed of carbon fiber. Wear respiratory protection when cutting body panels.
- In the event of a fire involving a charging station, reference the **FIRE** portion of this guide, and treat it as an energized electrical fire until power to the charger can be shut down.
- This vehicle does not have an internal combustion engine. Lack of engine noise does not mean vehicle is OFF. Silent movement capability exists until vehicle is fully shut down.

TESLA
Roadster 2



2010-13

TESLA



TESLA







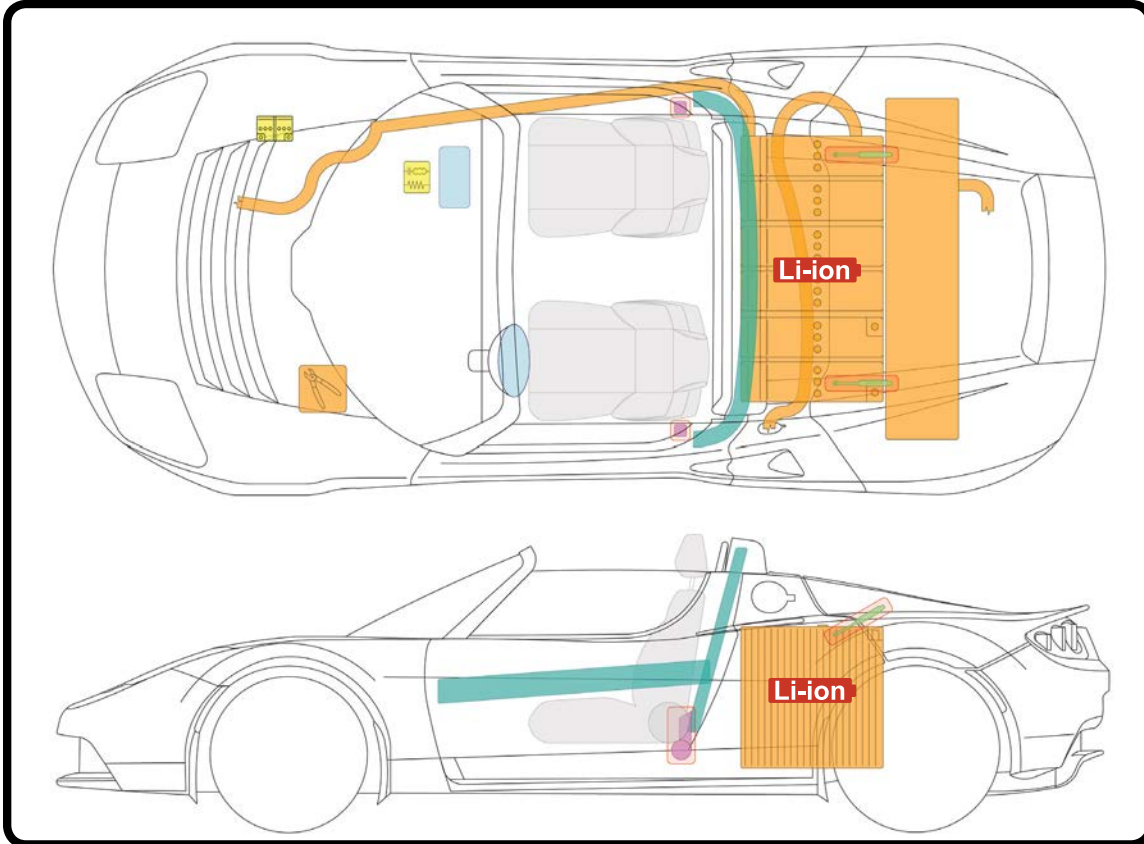

Roadster 2

Li-ion (continued) **EXTRICATION INFORMATION**

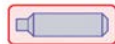
See pages 15, 22.

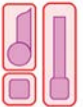

LEGEND

 Airbag	 Bodywork Reinforcements	 SRS Control Unit
 Stored Gas Inflator	 Support Cylinder for Hood	 12V Battery
 Seatbelt Tensioner or Pretensioner		 High-Voltage Power Cable
 High-Voltage Battery	 Emergency Disconnect (Cut Cable)	

For towing and post-incident instructions, see the **POST-INCIDENT** section on page 20.

TESLA



2013-15

HYBRID



TOYOTA

TOYOTA

A

V

A

L

O

VEHICLE INFORMATION

IMMOBILIZE VEHICLE

- 1. Chock the wheels.
- 2. Set parking brake. (foot pedal)
- 3. Place vehicle into park. (center console)

DISABLE VEHICLE

Determine if vehicle is ON by illumination of READY light.

PRIMARY PROCEDURE

- 1. If ON, shut off ignition (push-button, right of instrument panel).
- 2. Remove proximity key and keep it at least 16 feet (5 meters) from vehicle.
- 3. Disconnect negative 12V battery cable (trunk, passenger side).

ALTERNATE PROCEDURE

(if power button is inaccessible)

- 1. Remove under hood fuse box cover (driver's side).
- 2. Remove IG2-MAIN fuse (25A clear) from the engine compartment fuse box. If the correct fuse cannot be identified, pull all of the fuses in fuse box.
- 3. Disconnect 12V battery (trunk, passenger side)

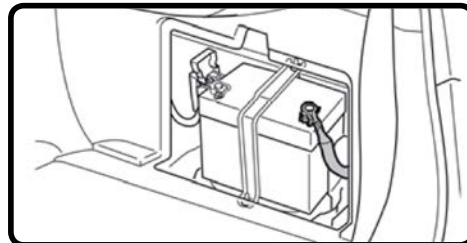

12V Battery in Trunk Passenger Side

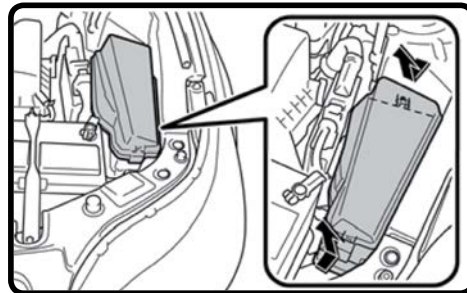



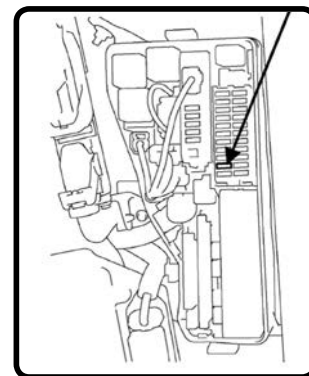

Engine Compartment Fuse Box Cover



Remove Fuse IG2-MAIN

WARNINGS

-  NEVER cut, breach, or touch high voltage components or cabling. Doing so could result in serious injury or death.
-  The high voltage system may remain powered for up to 10 minutes after shutoff/disabling. Avoid touching, cutting, or opening any orange high voltage cable or component.
-  Airbags and SRS may remain powered for up to 90 seconds after shutoff/disabling. Avoid breaching SRS components.
-  Lack of engine noise does not mean vehicle is OFF. Silent movement or instant restart capability exists until vehicle is fully shut down.











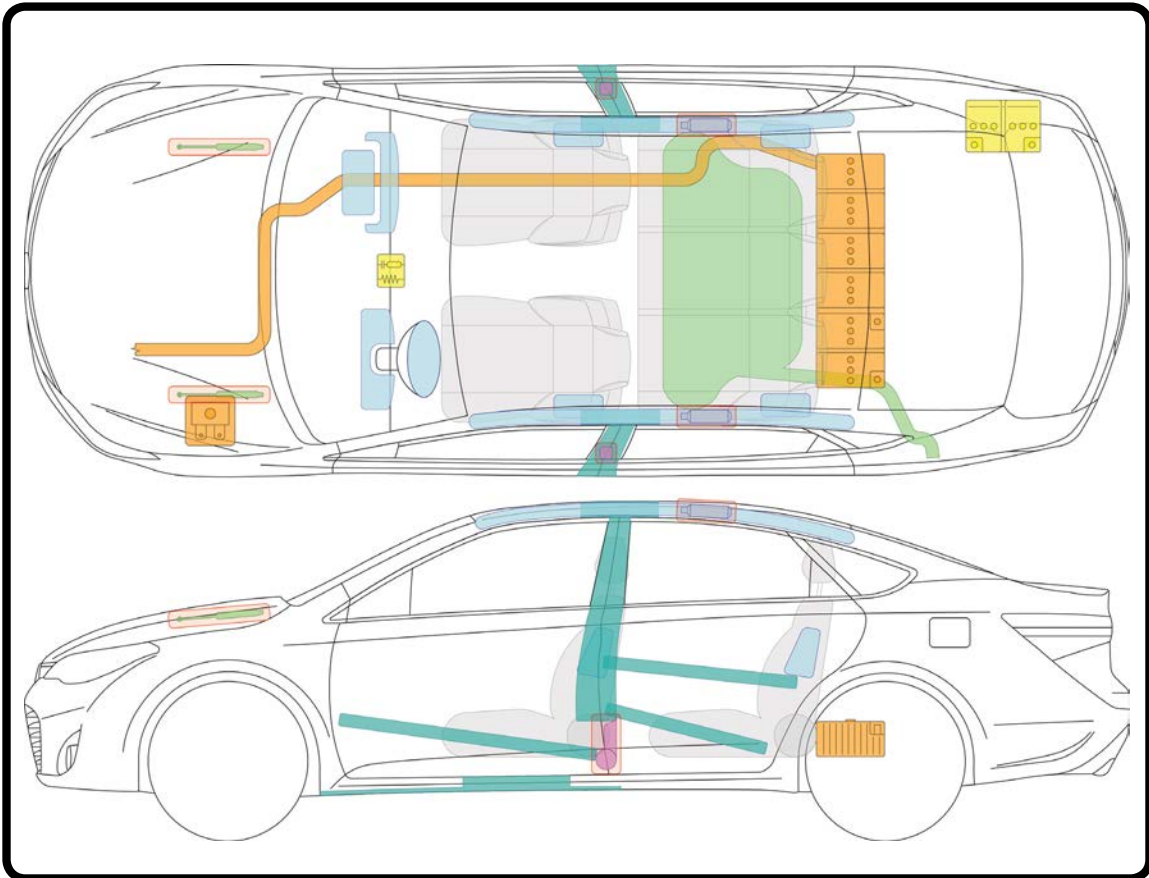

2013-15

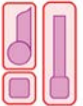
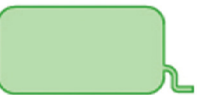

TOYOTA
AVALON

(continued) **EXTRICATION INFORMATION**

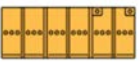

LEGEND		
 Airbag	 Bodywork Reinforcements	 SRS Control Unit
 Stored Gas Inflator	 Support Cylinder for Hood	 12V Battery
 Seatbelt Tensioner or Pretensioner	 Fuel Tank	 High-Voltage Power Cable
 High-Voltage Battery	 Emergency Disconnect (Remove Fuse)	

For towing and post-incident instructions, see the **POST-INCIDENT** section on page 20.



2016-18



HYBRID

VEHICLE INFORMATION

IMMOBILIZE VEHICLE

- 1. Chock the wheels.
- 2. Set parking brake. (foot pedal)
- 3. Place vehicle into park. (center console)

DISABLE VEHICLE

Determine if vehicle is ON by illumination of READY light.

PRIMARY PROCEDURE

- 1. If ON, shut off ignition (push-button, right of instrument panel).
- 2. Remove proximity key and keep it at least 16 feet (5 meters) from vehicle.
- 3. Disconnect negative 12V battery cable (trunk, passenger side).

ALTERNATE PROCEDURE

(if power button is inaccessible)

- 1. Remove under hood fuse box cover (driver's side).
- 2. Remove IG2-MAIN fuse (25A clear) from the engine compartment fuse box. If the correct fuse cannot be identified, pull all of the fuses in fuse box.
- 3. Disconnect negative 12V battery cable (trunk, passenger side).

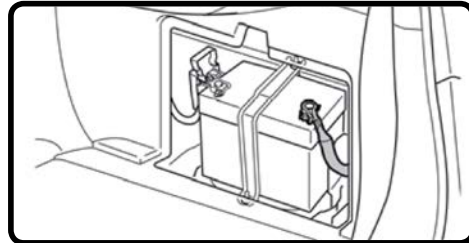

12V Battery in Trunk Passenger Side

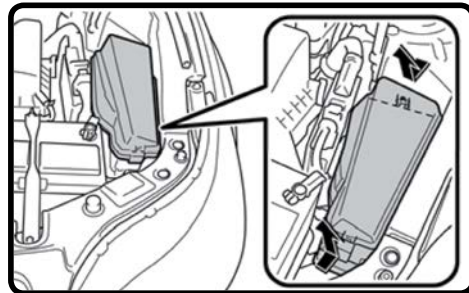



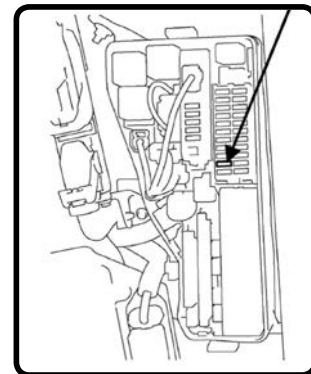

Engine Compartment Fuse Box Cover



Remove Fuse IG2-MAIN

WARNINGS

-  NEVER cut, breach, or touch high voltage components or cabling. Doing so could result in serious injury or death.
-  The high voltage system may remain powered for up to 10 minutes after shutoff/disabling. Avoid touching, cutting, or opening any orange high voltage cable or component.
-  Airbags and SRS may remain powered for up to 90 seconds after shutoff/disabling. Avoid breaching SRS components.
-  Lack of engine noise does not mean vehicle is OFF. Silent movement or instant restart capability exists until vehicle is fully shut down.

TOYOTA

TOYOTA

A V A L O N

HEV









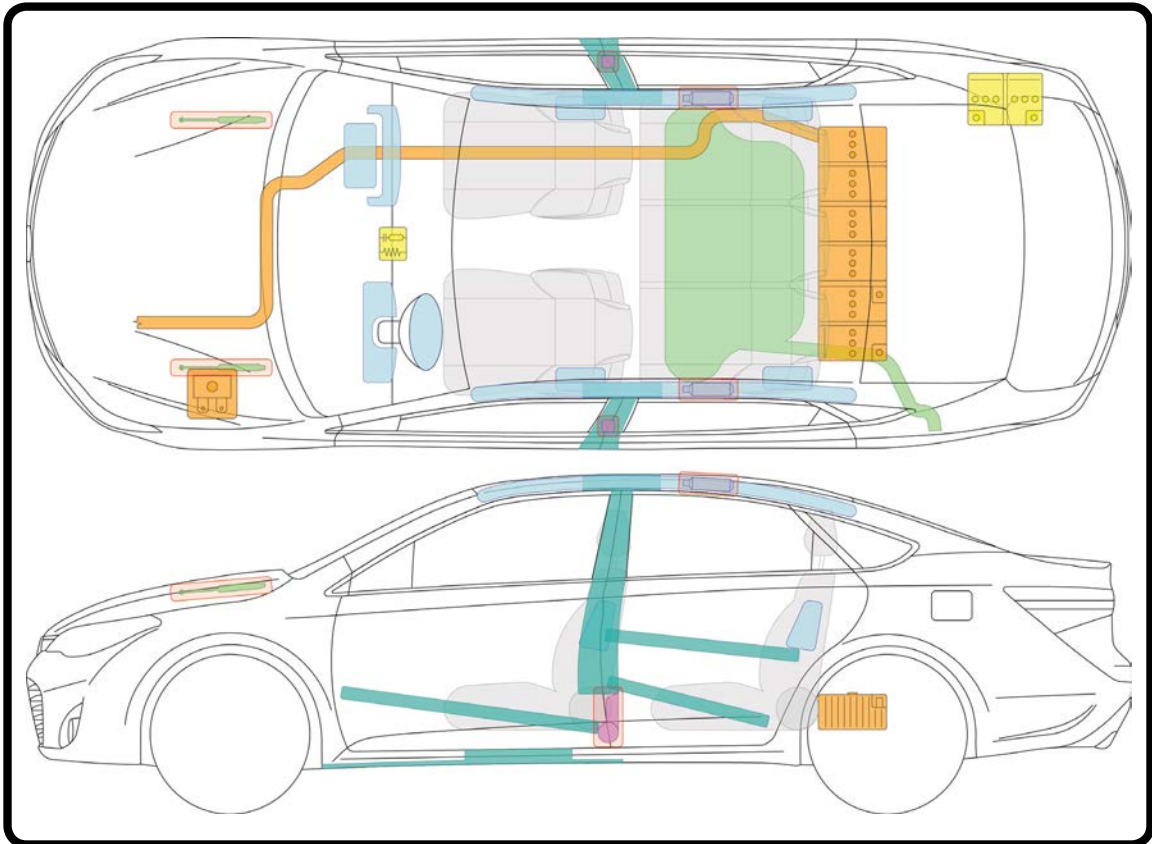

2016-18

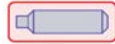

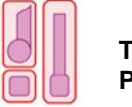
(continued) **EXTRICATION INFORMATION**

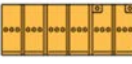

LEGEND		
 Airbag	 Bodywork Reinforcements	 SRS Control Unit
 Stored Gas Inflator	 Support Cylinder for Hood	 12V Battery
 Seatbelt Tensioner or Pretensioner	 Fuel Tank	 High-Voltage Power Cable
 High-Voltage Battery	 Emergency Disconnect (Remove Fuse)	

For towing and post-incident instructions, see the **POST-INCIDENT** section on page 20.

TOYOTA AVANZON



2019

HYBRID

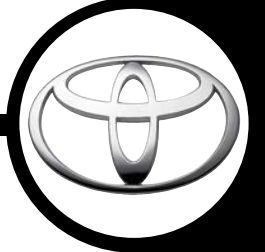

VEHICLE INFORMATION

IMMOBILIZE VEHICLE

- 1. Chock the wheels.
- 2. Set parking brake. (foot pedal)
- 3. Place vehicle into park. (center console)

DISABLE VEHICLE

Determine if vehicle is ON by illumination of READY light.

PRIMARY PROCEDURE

- 1. If ON, shut off ignition (push-button, right of instrument panel).
- 2. Remove proximity key and keep it at least 16 feet (5 meters) from vehicle.
- 3. Disconnect negative 12V battery cable (trunk, passenger side).

ALTERNATE PROCEDURE

(if power button is inaccessible)

- 1. Remove under hood fuse box cover (driver's side).
- 2. Remove IG2-MAIN fuse (20A yellow) from the engine compartment fuse box. If the correct fuse cannot be identified, pull all of the fuses in fuse box.
- 3. Disconnect negative 12V battery cable (trunk, passenger side).

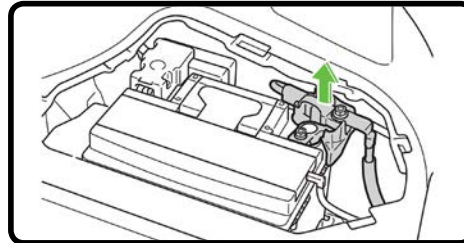

12V Battery in Trunk Passenger Side

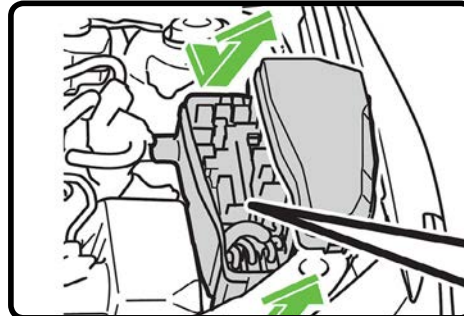



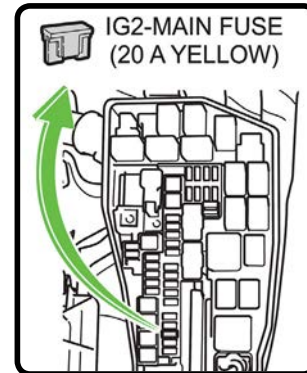

Engine Compartment Fuse Box Cover



Remove Fuse IG2-MAIN

WARNINGS

-  NEVER cut, breach, or touch high voltage components or cabling. Doing so could result in serious injury or death.
-  The high voltage system may remain powered for up to 10 minutes after shutoff/disabling. Avoid touching, cutting, or opening any orange high voltage cable or component.
-  Airbags and SRS may remain powered for up to 90 seconds after shutoff/disabling. Avoid breaching SRS components.
-  Lack of engine noise does not mean vehicle is OFF. Silent movement or instant restart capability exists until vehicle is fully shut down.

TOYOTA

TOYOTA

A

V

A

L

O



2019

HYBRID









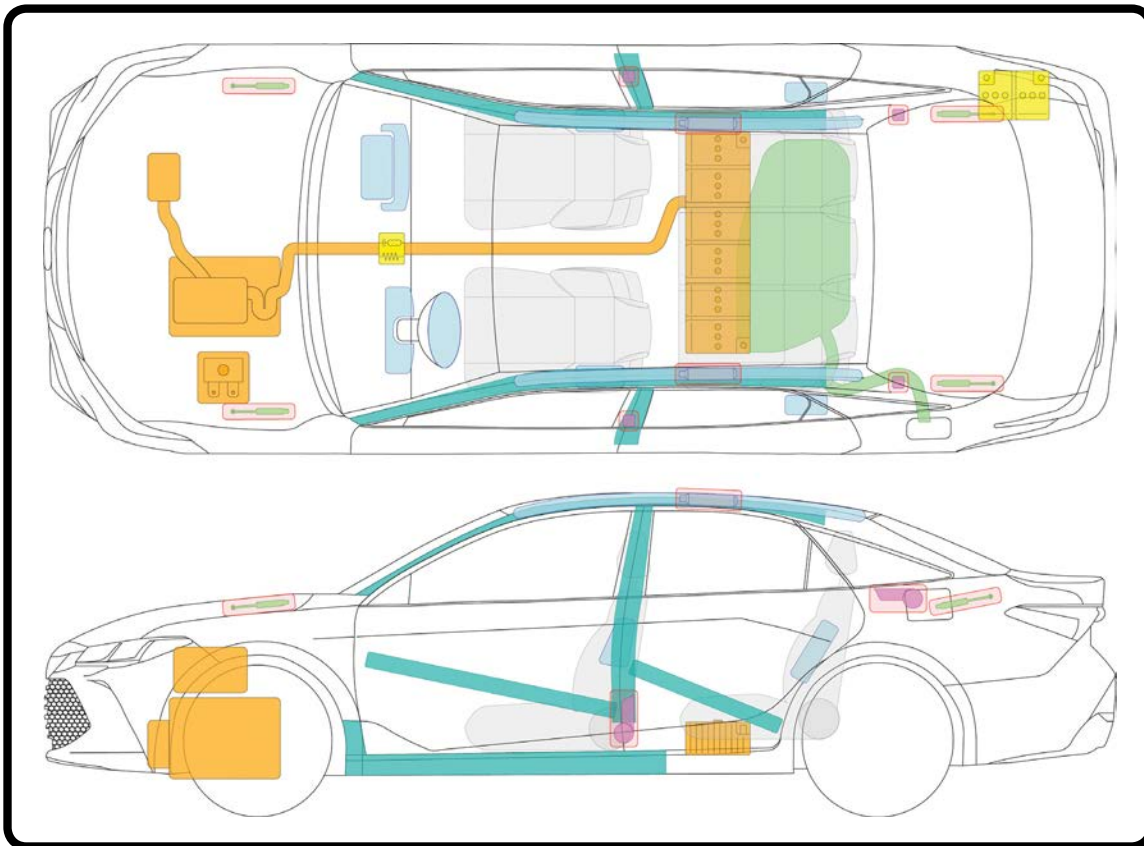

TOYOTA

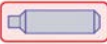
TOYOTA AVANZON

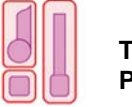
(continued) **EXTRICATION INFORMATION**

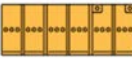

LEGEND		
 Airbag	 Bodywork Reinforcements	 SRS Control Unit
 Stored Gas Inflator	 Support Cylinder for Hood	 12V Battery
 Seatbelt Tensioner or Pretensioner	 Fuel Tank	 High-Voltage Power Cable
 High-Voltage Battery	 Emergency Disconnect (Remove Fuse)	

For towing and post-incident instructions, see the **POST-INCIDENT** section on page 20.



2007-11

HYBRID



TOYOTA

TOYOTA

CAMRY

VEHICLE INFORMATION

IMMOBILIZE VEHICLE

- 1. Chock the wheels.
- 2. Set parking brake. (foot pedal)
- 3. Place vehicle into park. (center console)

DISABLE VEHICLE

Determine if vehicle is ON by illumination of READY light.

PRIMARY PROCEDURE

- 1. If ON, shut off ignition (push-button, right of instrument panel). Remove proximity key and keep it at least 3.3 feet (1 meter) from vehicle.
- 2. Disconnect 12V battery (trunk).

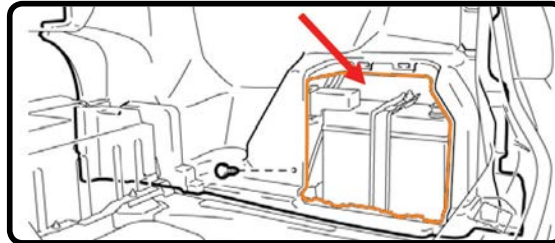

12V Battery Mounted in Trunk

ALTERNATE PROCEDURE

(if power button is inaccessible)

- 1. Disconnect 12V battery (trunk)
- 2. Remove underhood fuse box cover (driver's side).
- 3. Remove IGCT No. 2 fuse (10A red) from the engine compartment fuse box. If the correct fuse cannot be identified, pull all of the fuses in fuse box.

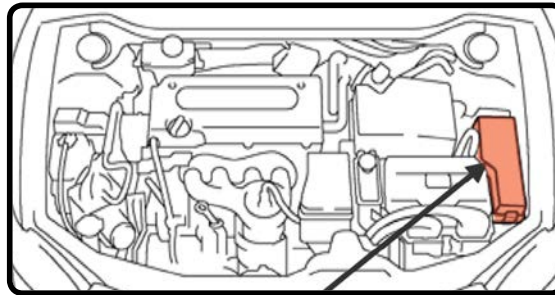



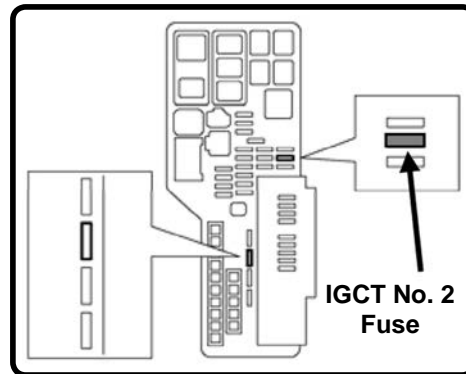

Engine Compartment Fuse Box Cover



Remove Fuse IGCT No. 2

WARNINGS

-  NEVER cut, breach, or touch high voltage components or cabling. Doing so could result in serious injury or death.
-  The high voltage system may remain powered for up to 10 minutes after shutoff/disabling. Avoid touching, cutting, or opening any orange high voltage cable or component.
-  Airbags and SRS may remain powered for up to 90 seconds after shutoff/disabling. Avoid breaching SRS components.
-  Lack of engine noise does not mean vehicle is OFF. Silent movement or instant restart capability exists until vehicle is fully shut down.

HEV











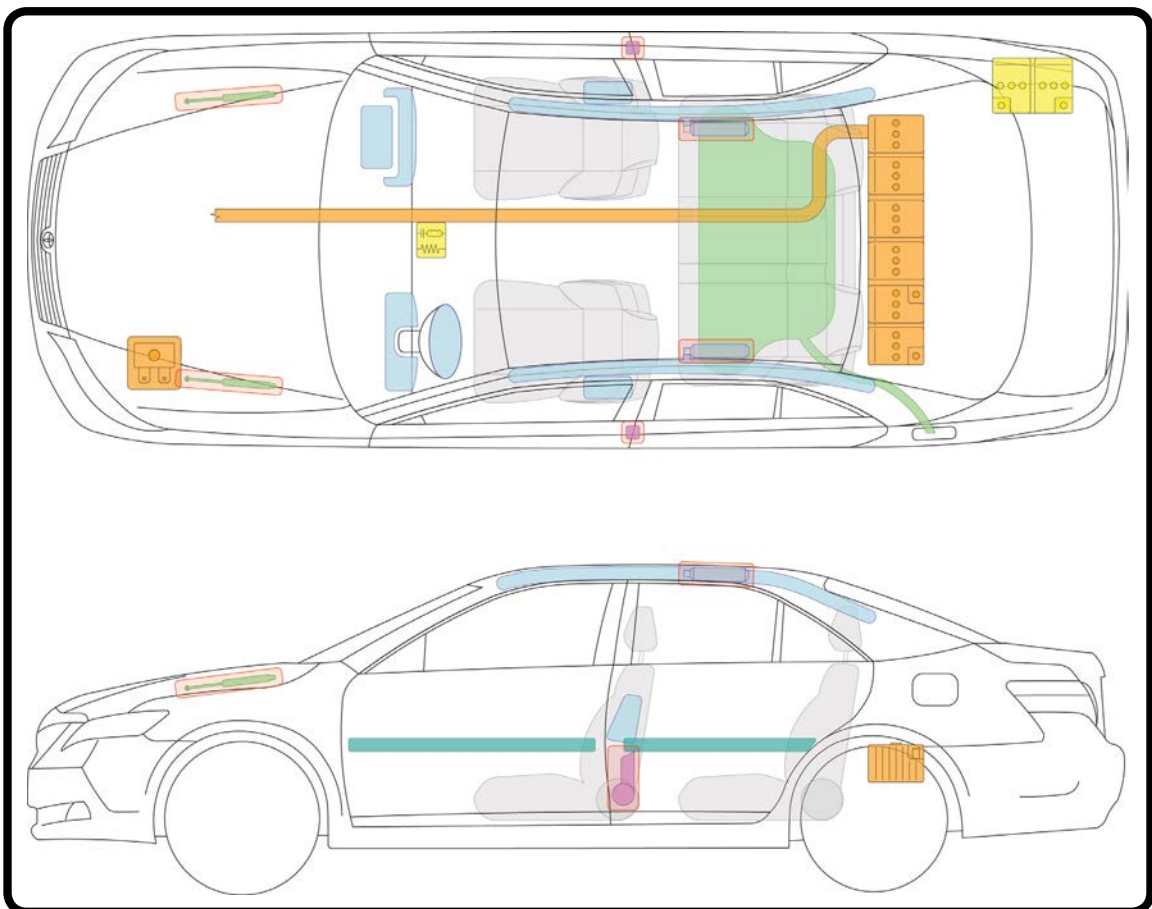

2007-11

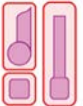

TOYOTA
CAMRY

(continued) **EXTRICATION INFORMATION**

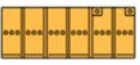

LEGEND		
 Airbag	 Bodywork Reinforcements	 SRS Control Unit
 Stored Gas Inflator	 Support Cylinder for Hood	 12V Battery
 Seatbelt Tensioner or Pretensioner	 Fuel Tank	 High-Voltage Power Cable
 High-Voltage Battery	 Emergency Disconnect (Remove Fuse)	

For towing and post-incident instructions, see the **POST-INCIDENT** section on page 20.



2012-17



HYBRID

VEHICLE INFORMATION

IMMOBILIZE VEHICLE

1. Chock the wheels.
2. Set parking brake. (foot pedal)
3. Place vehicle into park. (gear selector, center console)

DISABLE VEHICLE

Determine if vehicle is ON by illumination of READY indicator.

PRIMARY PROCEDURE

1. If ON, shut off ignition (push-button, right of instrument panel). Remove proximity key and keep it at least 16 feet (5 meters) from vehicle.
2. Disconnect 12V battery (trunk, right side).

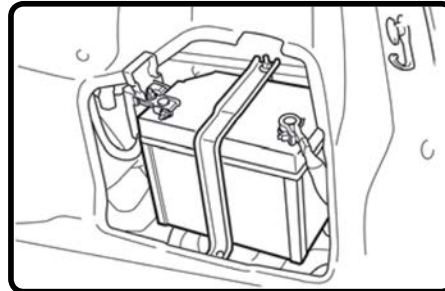

12V Battery in Right Side of Trunk

ALTERNATE PROCEDURE

(if power button is inaccessible)

1. Open hood and remove engine compartment fuse box cover (driver's side).
2. Remove IG2 fuse (25A clear) from the fuse box. If the correct fuse cannot be identified, pull all fuses in fuse box.
3. Disconnect 12V battery (trunk, right side).

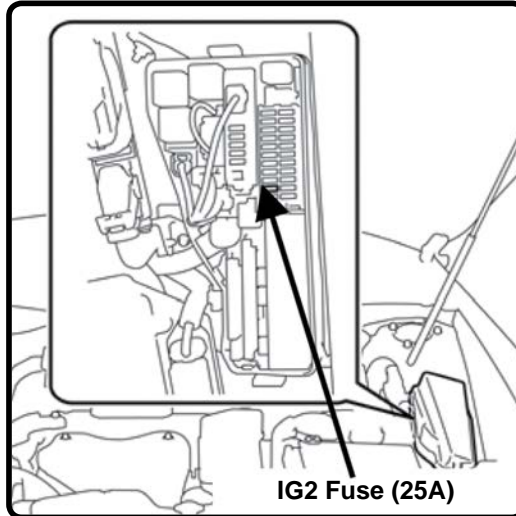

Remove Fuse IG2 in Engine Compartment

WARNINGS

- NEVER cut, breach, or touch high voltage components or cabling. Doing so could result in serious injury or death.
- The high voltage system may remain powered for up to 10 minutes after the vehicle is shut off.
- The SRS system (airbags, etc.) may remain powered for up to 90 seconds after disabling.
- There is a 27V AC Electric Power Steering (EPS) system behind the instrument cluster and routed a short distance along the steering column. 27V AC has a higher arc potential than 12V DC.
- Lack of engine noise does not mean vehicle is OFF. Silent movement or instant restart capability exists until vehicle is fully shut down.

TOYOTA

TOYOTA

CAMRY

HEV



2012-17



2015-17



2012-14

(continued) **EXTRICATION INFORMATION**

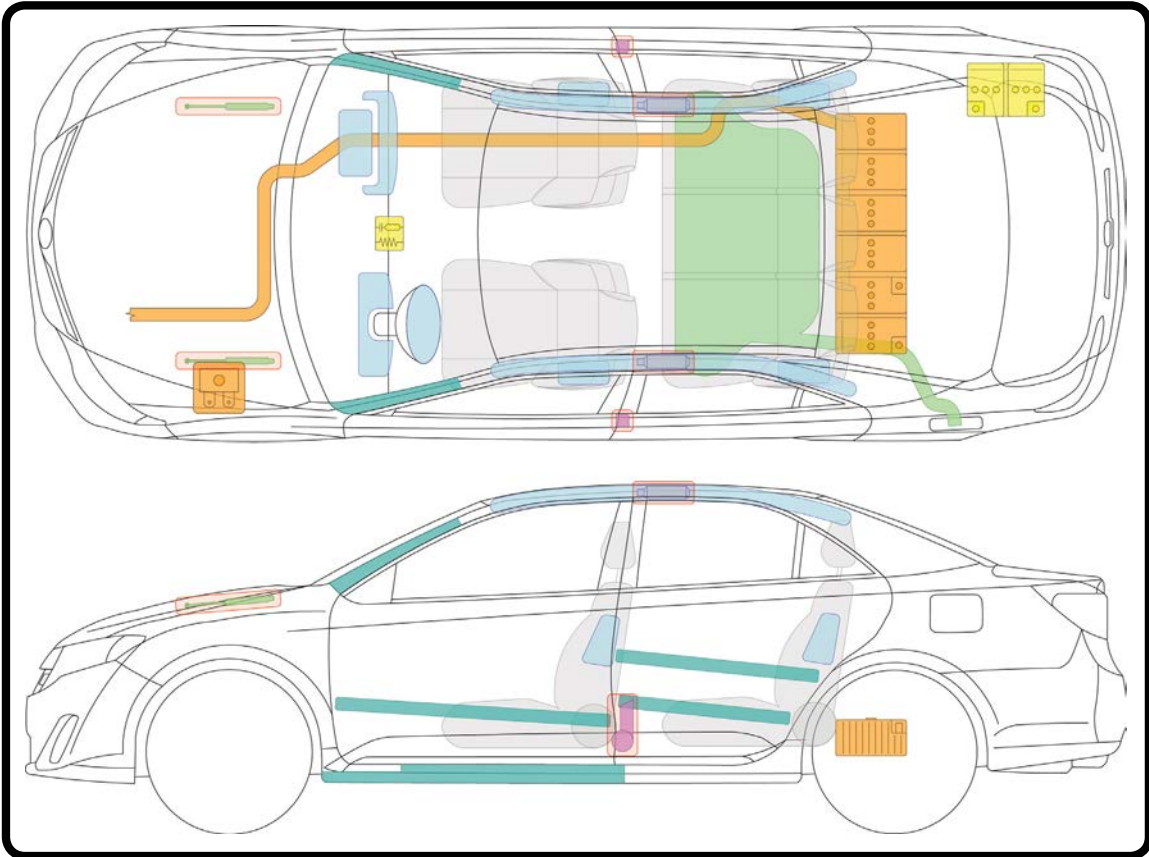

LEGEND

Airbag	Bodywork Reinforcements	SRS Control Unit
Stored Gas Inflator	Support Cylinder for Hood	12V Battery
Seatbelt Tensioner or Pretensioner	Fuel Tank	High-Voltage Power Cable
High-Voltage Battery	Emergency Disconnect (Remove Fuse)	

For towing and post-incident instructions, see the **POST-INCIDENT** section on page 20.



2018

HYBRID

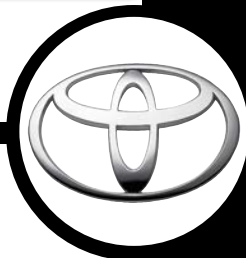

VEHICLE INFORMATION

Li-ion

See pages 15, 22.

IMMOBILIZE VEHICLE

1. **Chock the wheels.**
2. **Set parking brake.**
(push/pull switch, center console)
3. **Place vehicle into park.**
(gear selector, center console)

DISABLE VEHICLE

Determine if vehicle is ON by illumination of READY indicator.

PRIMARY PROCEDURE

1. If ON, shut off ignition (push-button, right of instrument panel).
2. Remove proximity key and keep it at least 16 feet (5 meters) from vehicle.
3. Disconnect negative 12V battery cable (trunk, right side).

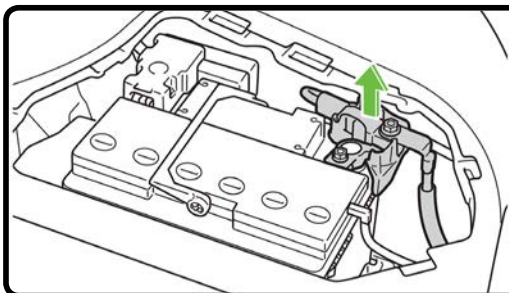

12V Battery in Right Side of Trunk

ALTERNATE PROCEDURE



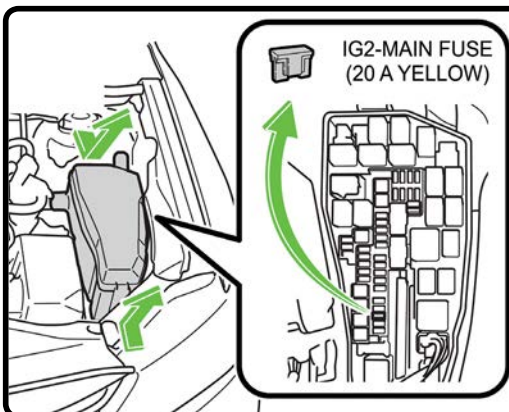

(if power button is inaccessible)

1. Open hood and remove engine compartment fuse box cover (driver's side).
2. Remove IG2 fuse (20A yellow) from the fuse box. If the correct fuse cannot be identified, pull all fuses in fuse box.
3. Disconnect negative 12V battery cable (trunk, right side).



Remove Fuse IG2 in Engine Compartment

WARNINGS

-  NEVER cut, breach, or touch high voltage components or cabling. Doing so could result in serious injury or death.
-  The high voltage system may remain powered for up to 10 minutes after shutoff/disabling. Avoid touching, cutting, or opening any orange high voltage cable or component.
-  Airbags and SRS may remain powered for up to 90 seconds after shutoff/disabling. Avoid breaching SRS components.
-  Lack of engine noise does not mean vehicle is OFF. Silent movement or instant restart capability exists until vehicle is fully shut down.

TOYOTA

TOYOTA

CAMRY

HEV



2018









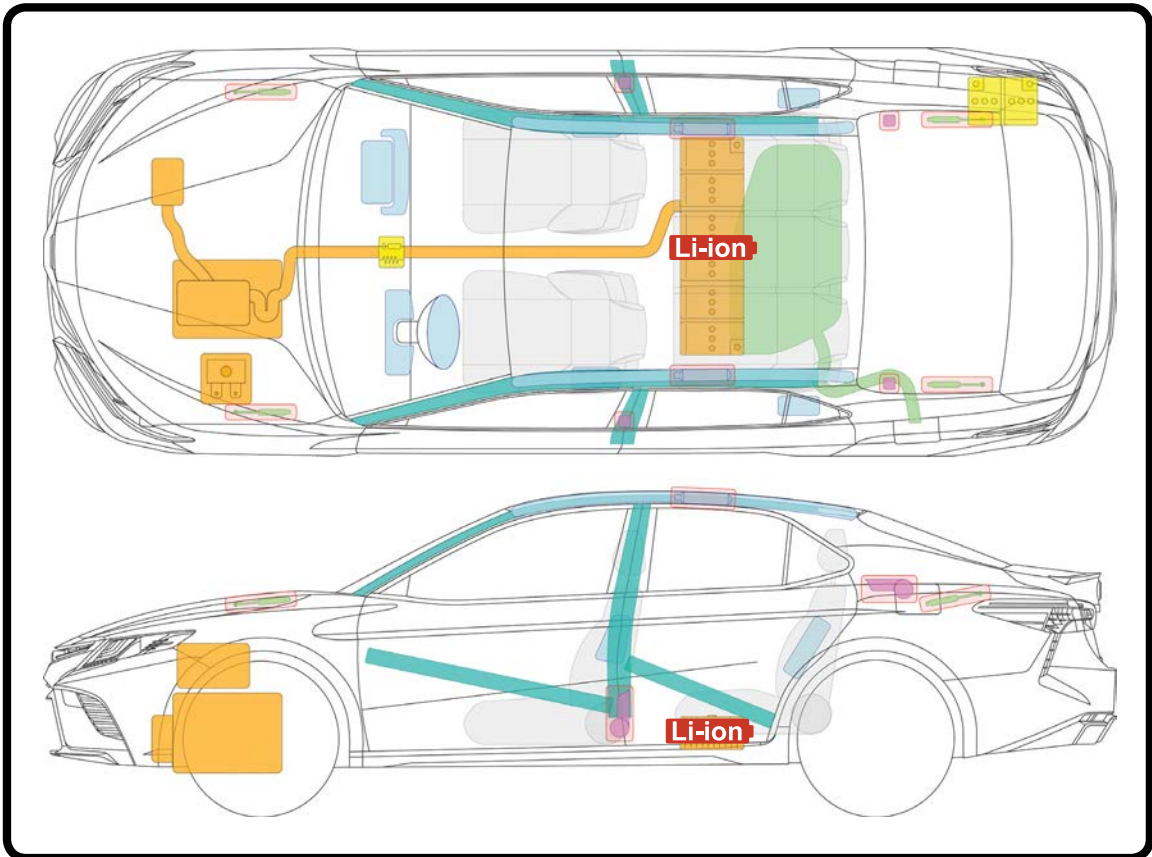



TOYOTA CAMRY

Li-ion (continued) **EXTRICATION INFORMATION**

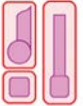
See pages 15, 22.



LEGEND		
 Airbag	 Bodywork Reinforcements	 SRS Control Unit
 Stored Gas Inflator	 Support Cylinder for Hood	 12V Battery
 Seatbelt Tensioner or Pretensioner	 Fuel Tank	 High-Voltage Power Cable
 High-Voltage Battery	 Emergency Disconnect (Remove Fuse)	

For towing and post-incident instructions, see the **POST-INCIDENT** section on page 20.



2006-07

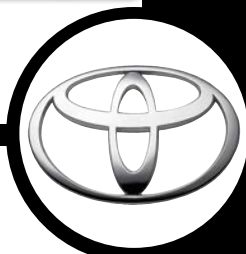

TOYOTA

TOYOTA

HIGHLANDER

VEHICLE INFORMATION

IMMOBILIZE VEHICLE

1. **Chock the wheels.**
2. **Set parking brake.**
(foot pedal)
3. **Place vehicle into park.**
(center console)

DISABLE VEHICLE

Determine if vehicle is ON by illumination of READY light.

PRIMARY PROCEDURE

1. If ON, turn the ignition key off (steering column) and remove key.
2. Disconnect 12V battery (engine compartment, passenger side).

ALTERNATE PROCEDURE

(if power button or ignition key is inaccessible)

1. Disconnect 12V battery (engine compartment, passenger side).
2. Remove fuse box cover (engine compartment, driver side) and remove the IGCT No.4 fuse (10A red). If the correct fuse cannot be identified, pull all fuses in fuse box.

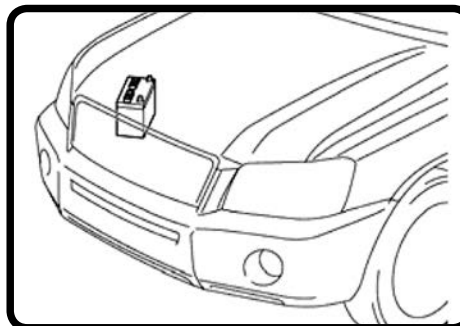



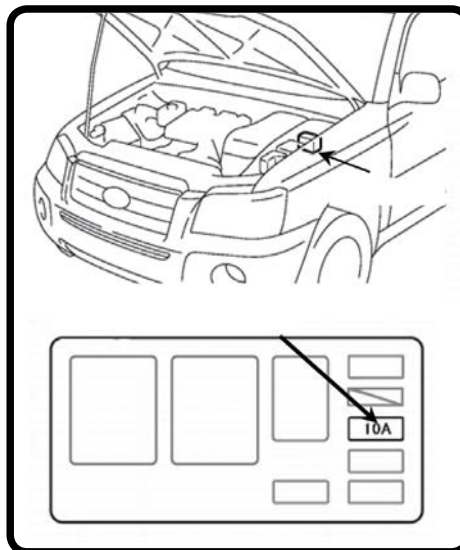

12V Battery



Fuse Box - IGCT No.4 (10A red)

WARNINGS

-  NEVER cut, breach, or touch high voltage components or cabling. Doing so could result in serious injury or death.
-  The high voltage system may remain powered for up to 5 minutes after shutoff/disabling. Avoid touching, cutting, or opening any orange high voltage cable or component.
-  Airbags and SRS may remain powered for up to 90 seconds after shutoff/disabling. Avoid breaching SRS components.
-  Lack of engine noise does not mean vehicle is OFF. Silent movement or instant restart capability exists until vehicle is fully shut down.

HEV



2006-07











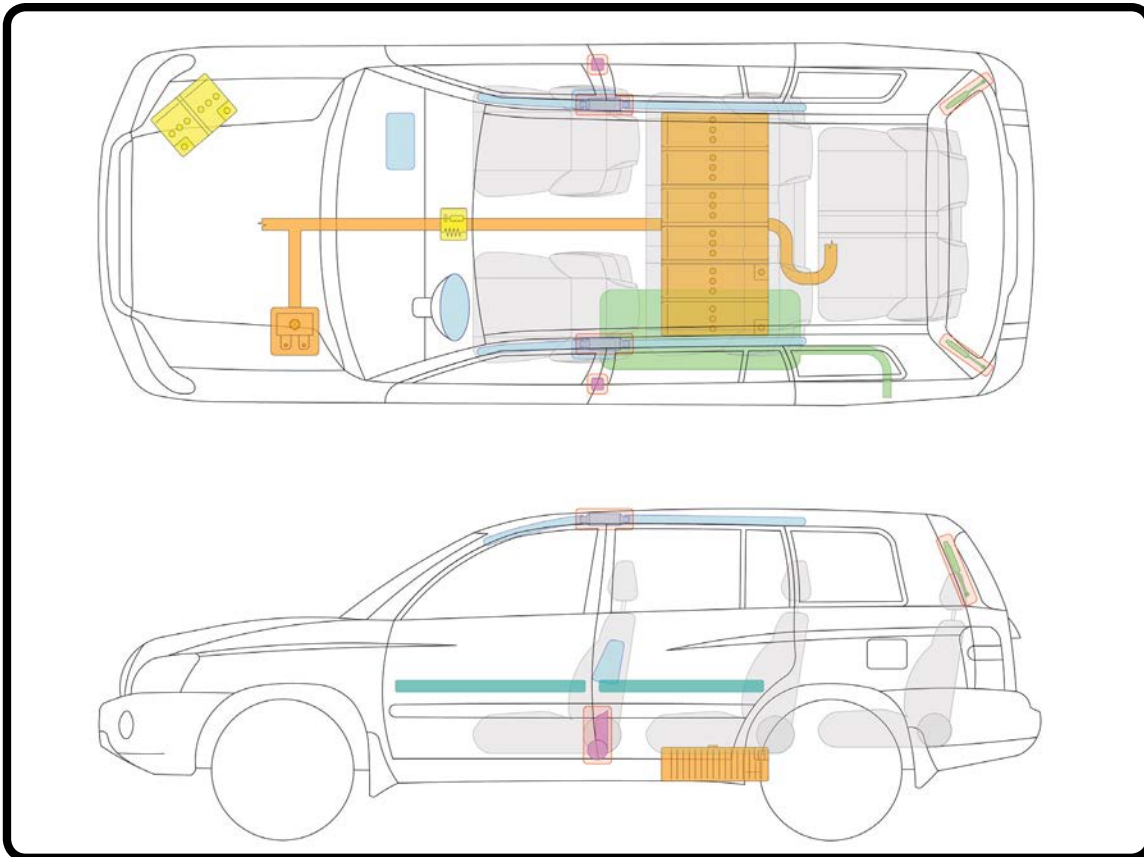

TOYOTA

HIGHLANDER

TOYOTA

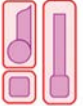
(continued) **EXTRICATION INFORMATION**

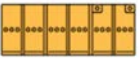

LEGEND		
 Airbag	 Bodywork Reinforcements	 SRS Control Unit
 Stored Gas Inflator	 Support Cylinder for Hood	 12V Battery
 Seatbelt Tensioner or Pretensioner	 Fuel Tank	 High-Voltage Power Cable
 High-Voltage Battery	 Emergency Disconnect (Remove Fuse)	

For towing and post-incident instructions, see the **POST-INCIDENT** section on page 20.



2008-10



2011-13

2008-13

HYBRID



VEHICLE INFORMATION

IMMOBILIZE VEHICLE

- 1. Chock the wheels.
- 2. Set parking brake. (foot pedal)
- 3. Place vehicle into park. (center console)

DISABLE VEHICLE

Determine if vehicle is ON by illumination of READY light.

PRIMARY PROCEDURE

- 1. If ON,
 - Conventional key: shut off ignition (instrument console) and remove key.
 - Proximity key: shut off ignition (push-button, center console). Remove key and keep it at least 16 feet (5 meters) from vehicle.
- 2. Disconnect 12V battery (engine compartment for 2008-2010, driver's side rear cargo area for 2011+).

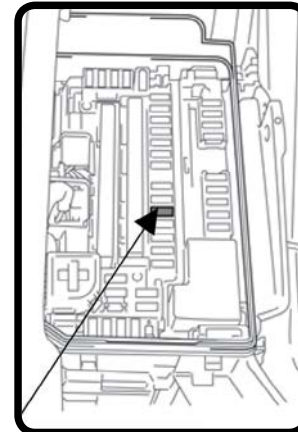

IGCT Fuse (30A Green)
2008-2010 Models

ALTERNATE PROCEDURE



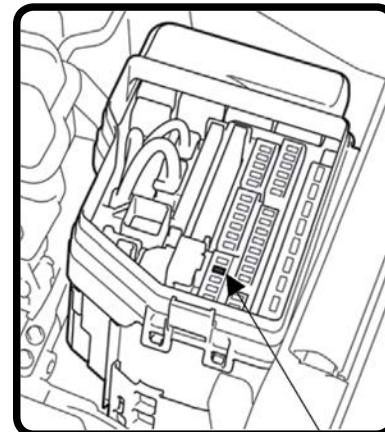

(if power button or ignition key is inaccessible)

- 1. Remove appropriate fuse in engine compartment fuse box:
 - 30A green IGCT fuse (2008-2010)
 - 30A green IG2 Main fuse (2011)
 If the correct fuse cannot be identified, pull all fuses in fuse box.
- 2. Disconnect 12V battery (engine compartment for 2008-2010, driver's side rear cargo area for 2011+).



IG2 MAIN Fuse (30A Green)
2011 Model

WARNINGS

-  NEVER cut, breach, or touch high voltage components or cabling. Doing so could result in serious injury or death.
-  The high voltage system may remain powered for up to 10 minutes after shutoff/disabling. Avoid touching, cutting, or opening any orange high voltage cable or component.
-  Airbags and SRS may remain powered for up to 90 seconds after shutoff/disabling. Avoid breaching SRS components.
-  Lack of engine noise does not mean vehicle is OFF. Silent movement or instant restart capability exists until vehicle is fully shut down.

TOYOTA

TOYOTA

HIGHLANDER

HEV



2008-13



TOYOTA HIGHLANDER

(continued) **EXTRICATION INFORMATION**

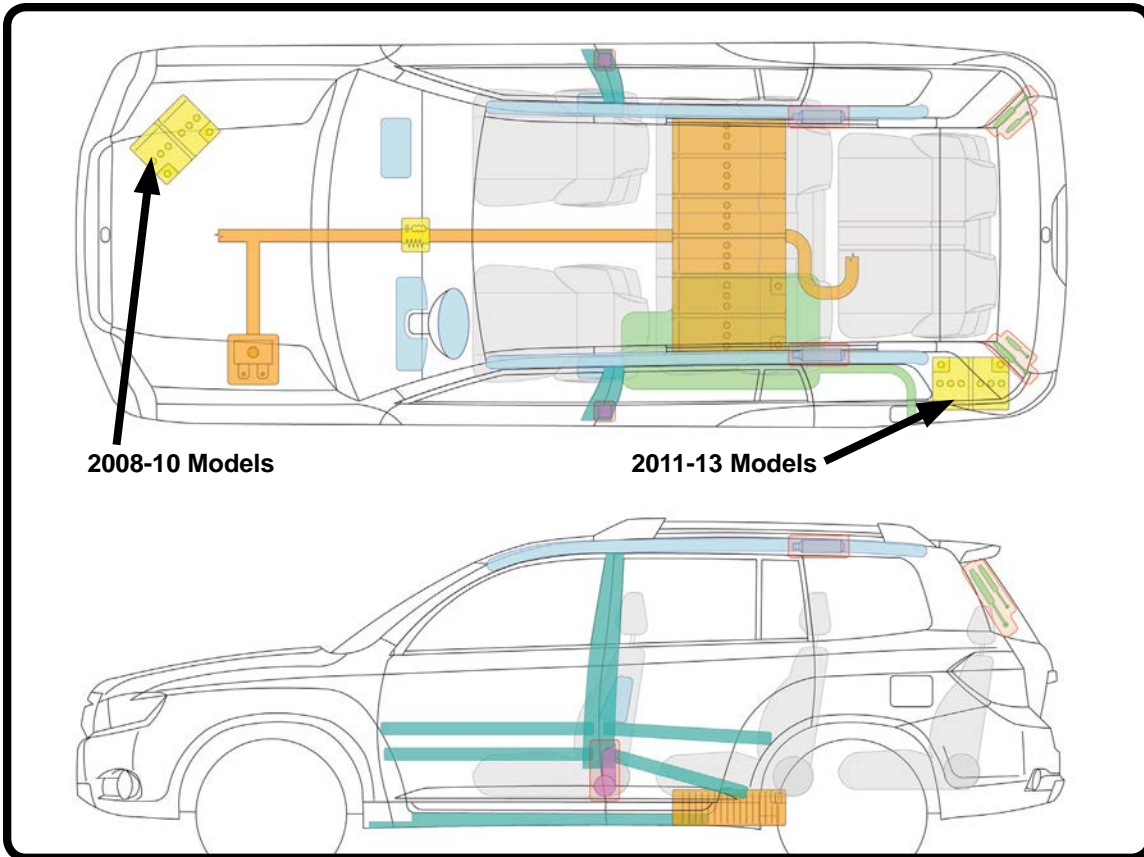

LEGEND		
	Airbag	
	Stored Gas Inflator	
	Seatbelt Tensioner or Pretensioner	
	High-Voltage Battery	

For towing and post-incident instructions, see the **POST-INCIDENT** section on page 20.



2014-18

HYBRID



TOYOTA

TOYOTA

HIGHLANDER

VEHICLE INFORMATION

IMMOBILIZE VEHICLE

- 1. Chock the wheels.
- 2. Set parking brake. (foot pedal)
- 3. Place vehicle into park. (center console)

DISABLE VEHICLE

Determine if vehicle is ON by illumination of READY light.

PRIMARY PROCEDURE

- 1. If ON, Shut off ignition (push-button, right of steering wheel).
- 2. Remove key and keep it at least 16 feet (5 meters) from vehicle.
- 3. Disconnect negative cable of the 12V battery (driver's side rear cargo area).

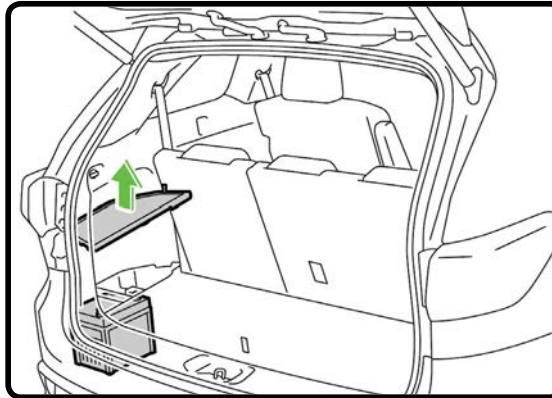

12V Auxiliary Battery Mounted in Trunk

ALTERNATE PROCEDURE



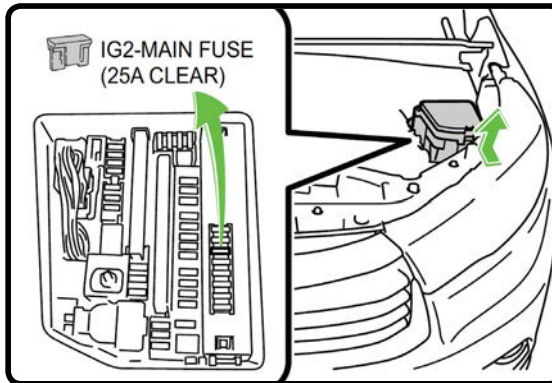

(if power button or ignition key is inaccessible)

- 1. Remove IG2-Main Fuse (25A clear) in engine compartment fuse box. If the correct fuse cannot be identified, pull all fuses in fuse box.
- 2. Disconnect negative cable of the 12V battery (driver's side rear cargo area).



IG2-Main Fuse (25A Clear)

WARNINGS

-  NEVER cut, breach, or touch high voltage components or cabling. Doing so could result in serious injury or death.
-  The high voltage system may remain powered for up to 10 minutes after shutoff/disabling. Avoid touching, cutting, or opening any orange high voltage cable or component.
-  Airbags and SRS may remain powered for up to 90 seconds after shutoff/disabling. Avoid breaching SRS components.
-  Lack of engine noise does not mean vehicle is OFF. Silent movement or instant restart capability exists until vehicle is fully shut down.

HEV



2014-18











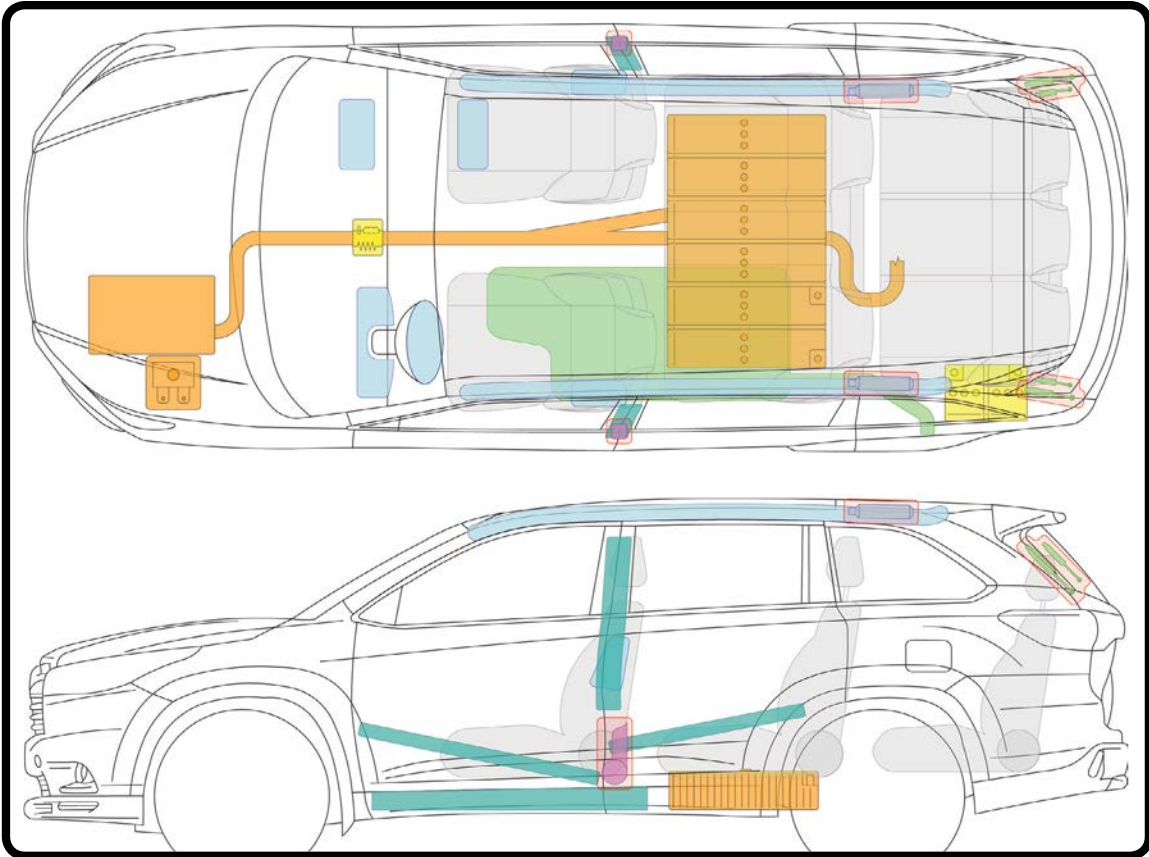

TOYOTA

HIGHLANDER

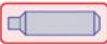
TOYOTA

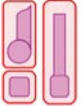
(continued) **EXTRICATION INFORMATION**

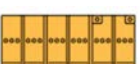

LEGEND		
 Airbag	 Bodywork Reinforcements	 SRS Control Unit
 Stored Gas Inflator	 Support Cylinder for Hood	 12V Battery
 Seatbelt Tensioner or Pretensioner	 Fuel Tank	 High-Voltage Power Cable
 High-Voltage Battery	 Emergency Disconnect (Remove Fuse)	

For towing and post-incident instructions, see the **POST-INCIDENT** section on page 20.



2005-08

FCHV









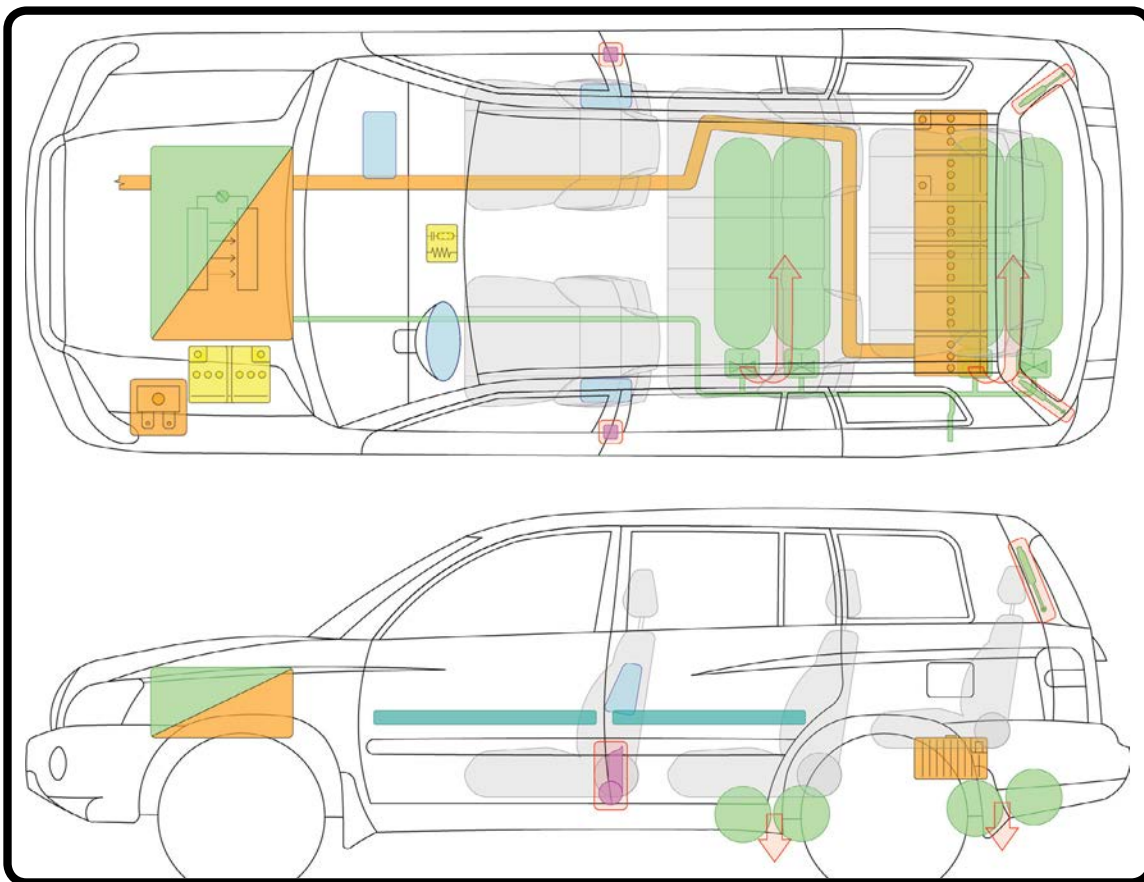

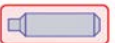

See page 24.

(continued)

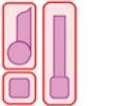
EXTRICATION INFORMATION



LEGEND

 Airbag	 Bodywork Reinforcements	 SRS Control Unit
 Stored Gas Inflator	 Support Cylinder for Hood	 12V Battery
 Seatbelt Tensioner or Pretensioner	 Fuel Tank	 High-Voltage Power Cable
 High-Voltage Battery	 Emergency Disconnect (Remove Fuse)	 Pressure Relief Valve

For towing and post-incident instructions, see the **POST-INCIDENT** section on page 20.



2009-14

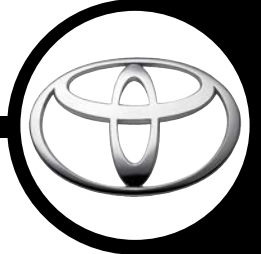

TOYOTA

FCHV-adv

VEHICLE INFORMATION

H
See page 24.

IMMOBILIZE VEHICLE

1. **Chock the wheels.**
2. **Set parking brake.**
(foot pedal)
3. **Place vehicle into park.**
(center console)

DISABLE VEHICLE

Determine if vehicle is ON by illumination of READY light.

PRIMARY PROCEDURE

1. If ON, turn the ignition key to the OFF position and remove key.
2. Disconnect 12V battery negative cable (engine compartment, driver's side).

ALTERNATE PROCEDURE

(if ignition key is inaccessible)

1. Disconnect 12V battery negative cable (engine compartment, driver's side).
2. Remove IGCT No 1 and IGCTFC fuses from the engine compartment fuse box. If the correct fuse cannot be identified, pull all of the fuses in fuse box.

SPECIAL CONCERNS

PRESSURE RELIEF VALVE (PRV)

PRV's quickly vent hydrogen when necessary to prevent excessive pressure in tanks.

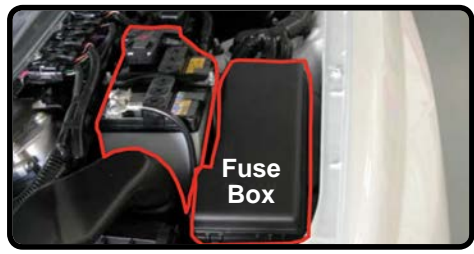

12V Battery and Fuse Box Location

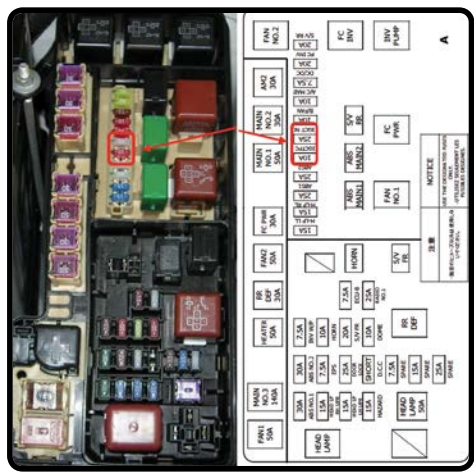

Remove Fuse IGCT and IGCTFC

WARNINGS

- NEVER cut, breach, or touch high voltage components or cabling. Doing so could result in serious injury or death.
- Residual hydrogen gas remains in the red lines forward of the tanks, in the hydrogen pump, and in the fuel cell. Avoid touching, cutting, or opening any red hydrogen line.
- If hissing is heard from hydrogen lines, it may be hydrogen gas releasing. The gas may ignite causing a flame that may be invisible. Stay away from vehicle until hissing stops.
- The high voltage system may remain powered for up to 5 minutes after shutoff/disabling. Avoid touching, cutting, or opening any orange high voltage cable or component.
- Airbags and SRS may remain powered for up to 90 seconds after shutoff/disabling. Avoid breaching SRS components.
- Fuel cell vehicles operate silently, lack of an engine noise does not mean the vehicle is OFF. Silent movement capability exists until vehicle is fully shut down.

TOYOTA HIGHLANDER FCHV



2009-14



FCHV-adv



See page 24.

(continued)

EXTRICATION INFORMATION

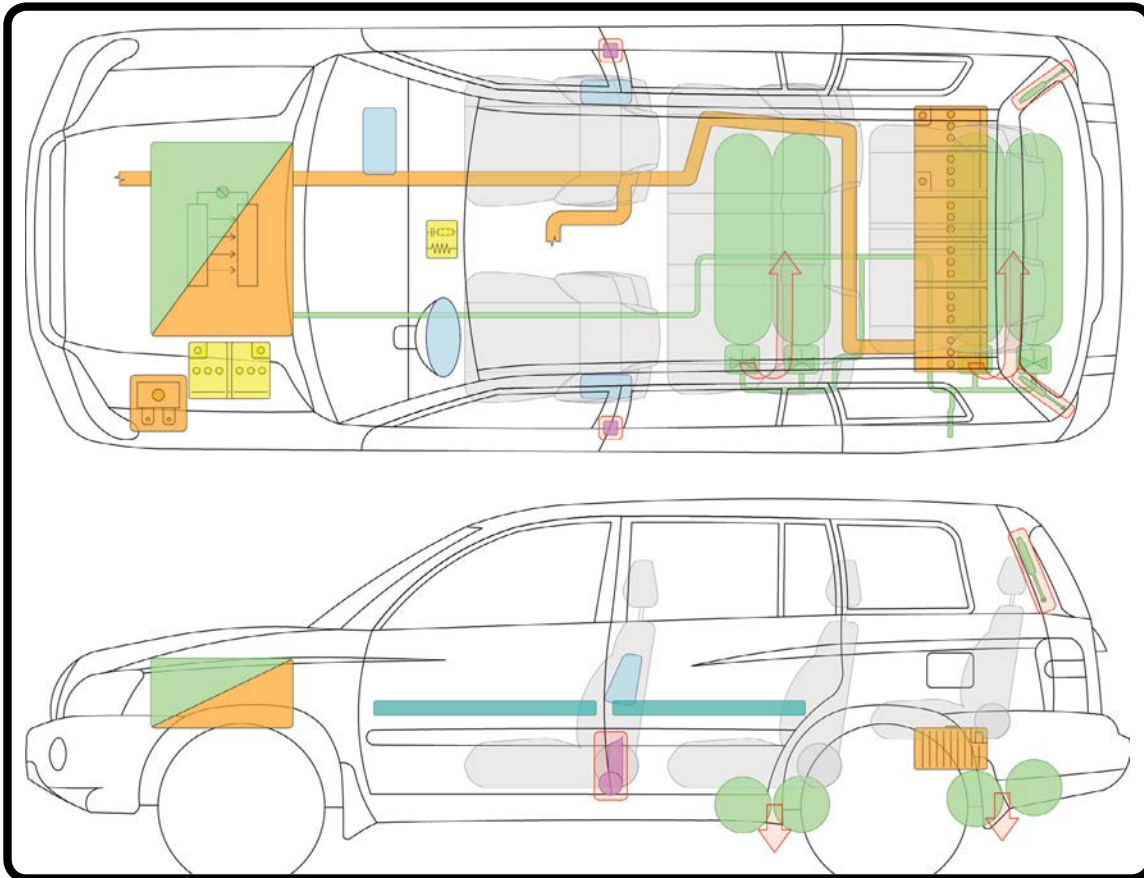

LEGEND

Airbag	Bodywork Reinforcements	SRS Control Unit
Stored Gas Inflator	Support Cylinder for Hood	12V Battery
Seatbelt Tensioner or Pretensioner	Fuel Tank	High-Voltage Power Cable
High-Voltage Battery	Emergency Disconnect (Remove Fuse)	Pressure Relief Valve

For towing and post-incident instructions, see the **POST-INCIDENT** section on page 20.



2016-18

FUELCELL



TOYOTA

TOYOTA

MIRAI

VEHICLE INFORMATION

 See page 24.

IMMOBILIZE VEHICLE

1. Chock the wheels.
2. Set parking brake. (foot pedal)
3. Place vehicle into park. (center console)

DISABLE VEHICLE

Determine if vehicle is ON by illumination of READY light.

1. If ON, shut off ignition (push POWER button, right of steering wheel). Remove proximity key and keep it at least 16 feet (5 meters) from vehicle.
2. Disconnect 12V battery negative cable (trunk, passenger side).

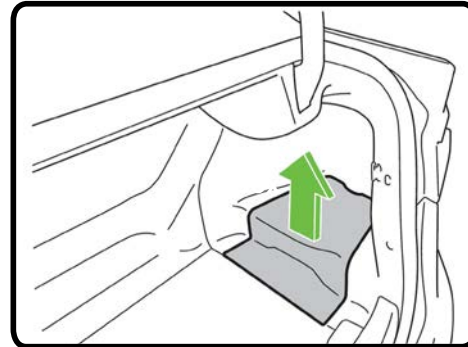

12V Battery Location

ALTERNATE PROCEDURE

(if power button is inaccessible)

1. Open hood and remove engine compartment fuse box cover (driver's side).
2. Remove IG2-MAIN fuse (15A blue) from the fuse box. If the correct fuse cannot be identified, pull all fuses in fuse box.
3. Disconnect 12V battery negative cable (trunk, passenger side).

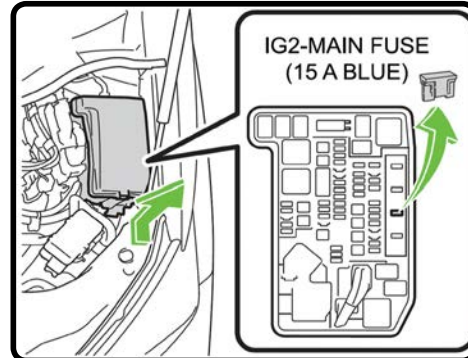







Remove Fuse IG2-MAIN (15A Blue)

SPECIAL CONCERNS

PRESSURE RELIEF VALVE (PRV)

PRV's quickly vent hydrogen when necessary to prevent excessive pressure in cylinder.

WARNINGS

-  NEVER cut, breach, or touch high voltage components or cabling. Doing so could result in serious injury or death.
-  Residual hydrogen gas remains in the red lines forward of the tanks, in the hydrogen pump, and in the fuel cell. Avoid touching, cutting, or opening any red hydrogen line.
-  If hissing is heard from hydrogen lines, it may be hydrogen gas releasing. The gas may ignite causing a flame that may be invisible. Stay away from vehicle until hissing stops.
-  The high voltage system may remain powered for up to 10 minutes after shutoff/disabling. Avoid touching, cutting, or opening any orange high voltage cable or component.
-  Airbags and SRS may remain powered for up to 90 seconds after shutoff/disabling. Avoid breaching SRS components.
-  Fuel cell vehicles operate silently, lack of an engine noise does not mean the vehicle is OFF. Silent movement capability exists until vehicle is fully shut down.



2016-18

FUEL CELL



See page 24.

(continued)

EXTRICATION INFORMATION

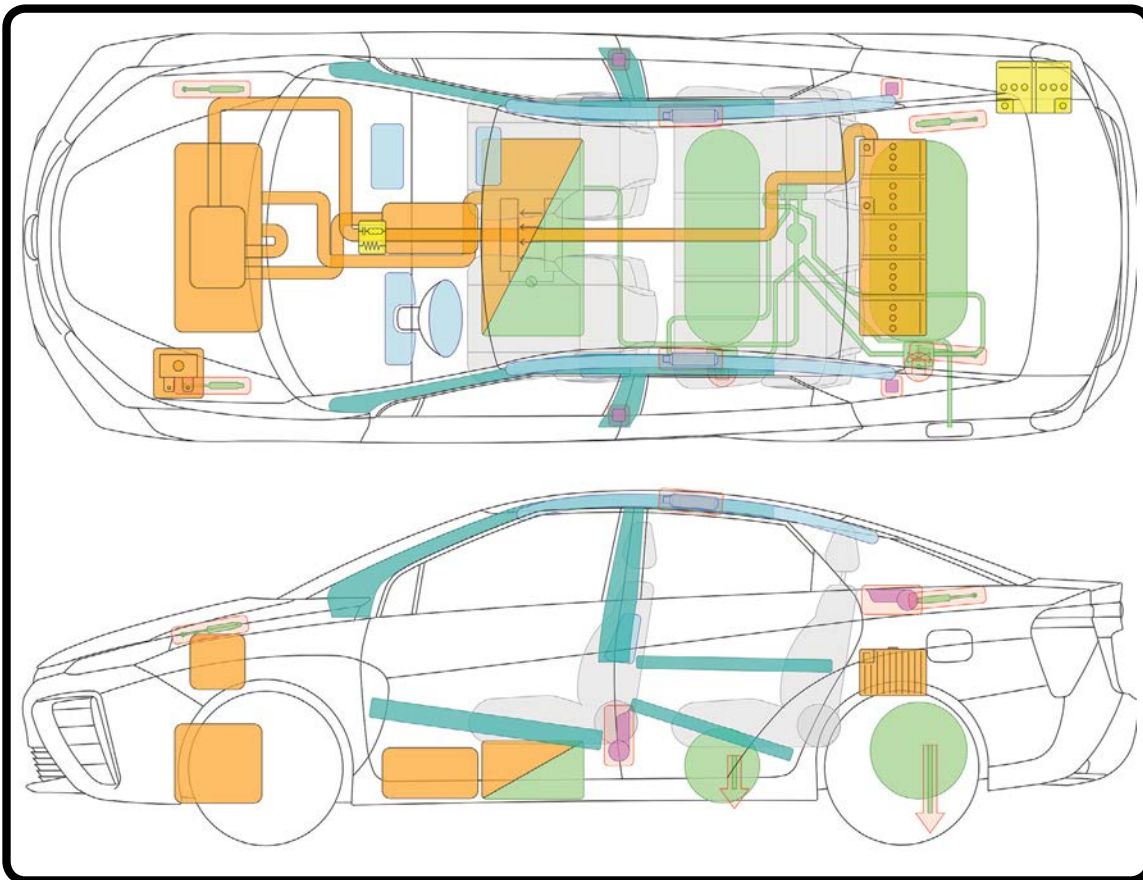

LEGEND

Airbag	Bodywork Reinforcements	SRS Control Unit
Stored Gas Inflator	Support Cylinder for Hood	12V Battery
Seatbelt Tensioner or Pretensioner	Fuel Tank	High-Voltage Power Cable
High-Voltage Battery	Emergency Disconnect (Remove Fuse)	Pressure Relief Valve

For towing and post-incident instructions, see the **POST-INCIDENT** section on page 20.



2001-03

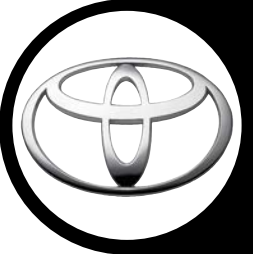

TOYOTA

TOYOTA

PRIVUS

VEHICLE INFORMATION

IMMOBILIZE VEHICLE

- 1. **Chock the wheels.**
- 2. **Set parking brake.**
(foot pedal)
- 3. **Place vehicle into park.**
(gear selector, steering column)

DISABLE VEHICLE

Determine if vehicle is ON by illumination of READY light.

PRIMARY PROCEDURE

- 1. If ON, turn the ignition key off (steering column) and remove the key.
- 2. Disconnect 12V battery (trunk, driver side).

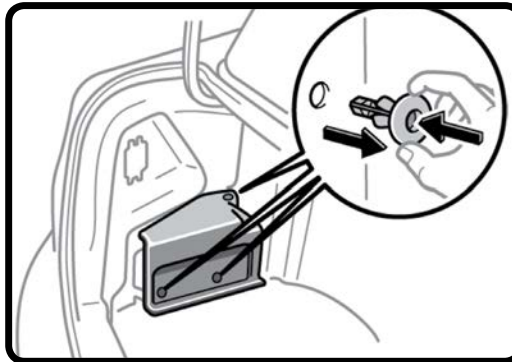

12V Battery

ALTERNATE PROCEDURE



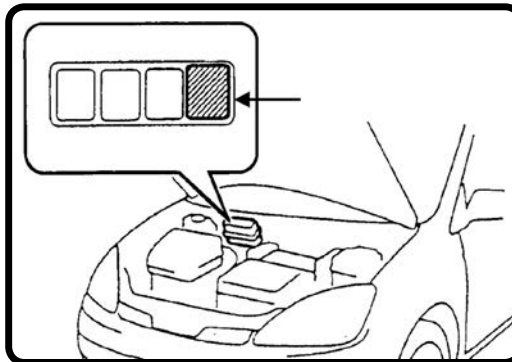

(if ignition is inaccessible)

- 1. Disconnect 12V battery (trunk, driver side).
- 2. Remove engine compartment fuse box cover (passenger side).
- 3. Remove IGCT Relay from the fuse box. If correct fuse cannot be identified, pull all the fuses in fuse box.



IGCT Relay

WARNINGS

-  NEVER cut, breach, or touch high voltage components or cabling. Doing so could result in serious injury or death.
-  The high voltage system may remain powered for up to 5 minutes after shutoff/disabling. Avoid touching, cutting, or opening any orange high voltage cable or component.
-  Airbags and SRS may remain powered for up to 90 seconds after shutoff/disabling. Avoid breaching SRS components.
-  Lack of engine noise does not mean vehicle is OFF. Silent movement or instant restart capability exists until vehicle is fully shut down.

HEV



2001-03

HYBRID



PRIUS

TOYOTA

TOYOTA

(continued) **EXTRICATION INFORMATION**

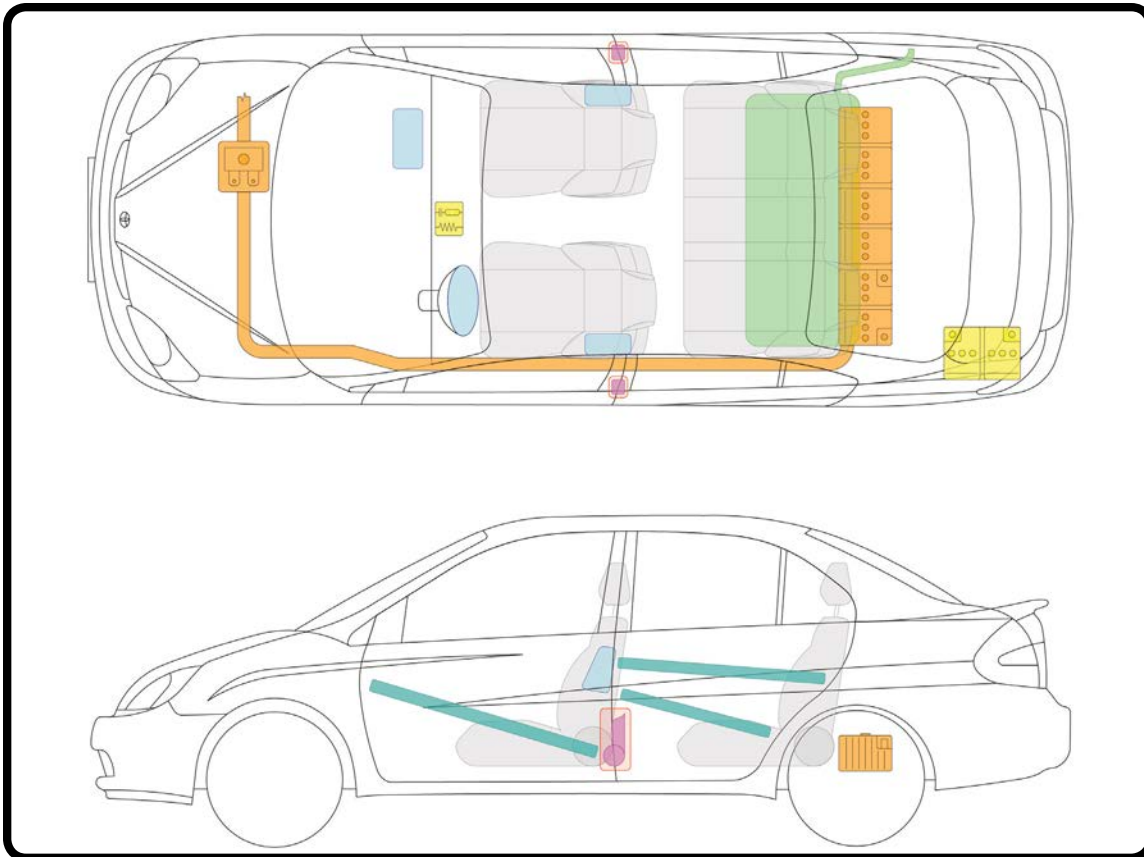

LEGEND		
	Airbag	
	Stored Gas Inflator	
	Seatbelt Tensioner or Pretensioner	
	Bodywork Reinforcements	
	Support Cylinder for Hood	
	High-Voltage Battery	

For towing and post-incident instructions, see the **POST-INCIDENT** section on page 20.



2004-09

HYBRID



VEHICLE INFORMATION

IMMOBILIZE VEHICLE

1. **Chock the wheels.**
2. **Set parking brake.**
(foot pedal)
3. **Place vehicle into park.**
(push-button, above gear selector)

DISABLE VEHICLE

Determine if vehicle is ON by illumination of READY light.

PRIMARY PROCEDURE

1. If ON, shut off ignition (push-button, right of instrument panel). Remove proximity key and keep it at least 16 feet (5 meters) from vehicle.
2. Disconnect 12V battery (cargo area right side).

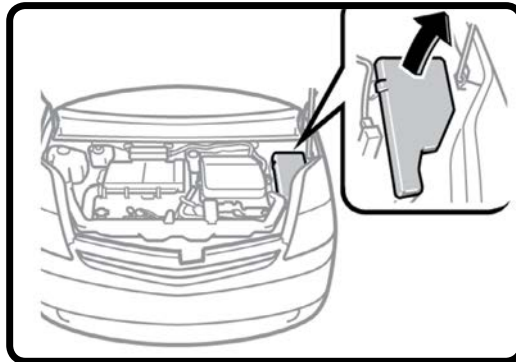

Remove Junction Block Cover

ALTERNATE PROCEDURE



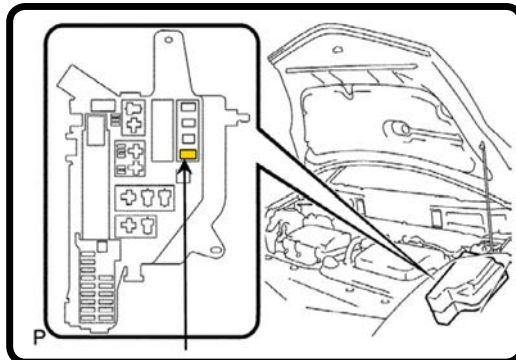

(if power button is inaccessible)

1. Disconnect 12V auxiliary battery (cargo area, right side).
2. Remove engine compartment fuse box cover (driver's side).
3. Remove HEV fuse (20A yellow) from the fuse box. If correct fuse cannot be identified, pull all the fuses in fuse box.



HEV Fuse 20A (Yellow)

WARNINGS

-  NEVER cut, breach, or touch high voltage components or cabling. Doing so could result in serious injury or death.
-  The high voltage system may remain powered for up to 10 minutes after shutoff/disabling. Avoid touching, cutting, or opening any orange high voltage cable or component.
-  Airbags and SRS may remain powered for up to 90 seconds after shutoff/disabling. Avoid breaching SRS components.
-  Lack of engine noise does not mean vehicle is OFF. Silent movement or instant restart capability exists until vehicle is fully shut down.

TOYOTA

TOYOTA

PRIVUS

HEV



2004-09









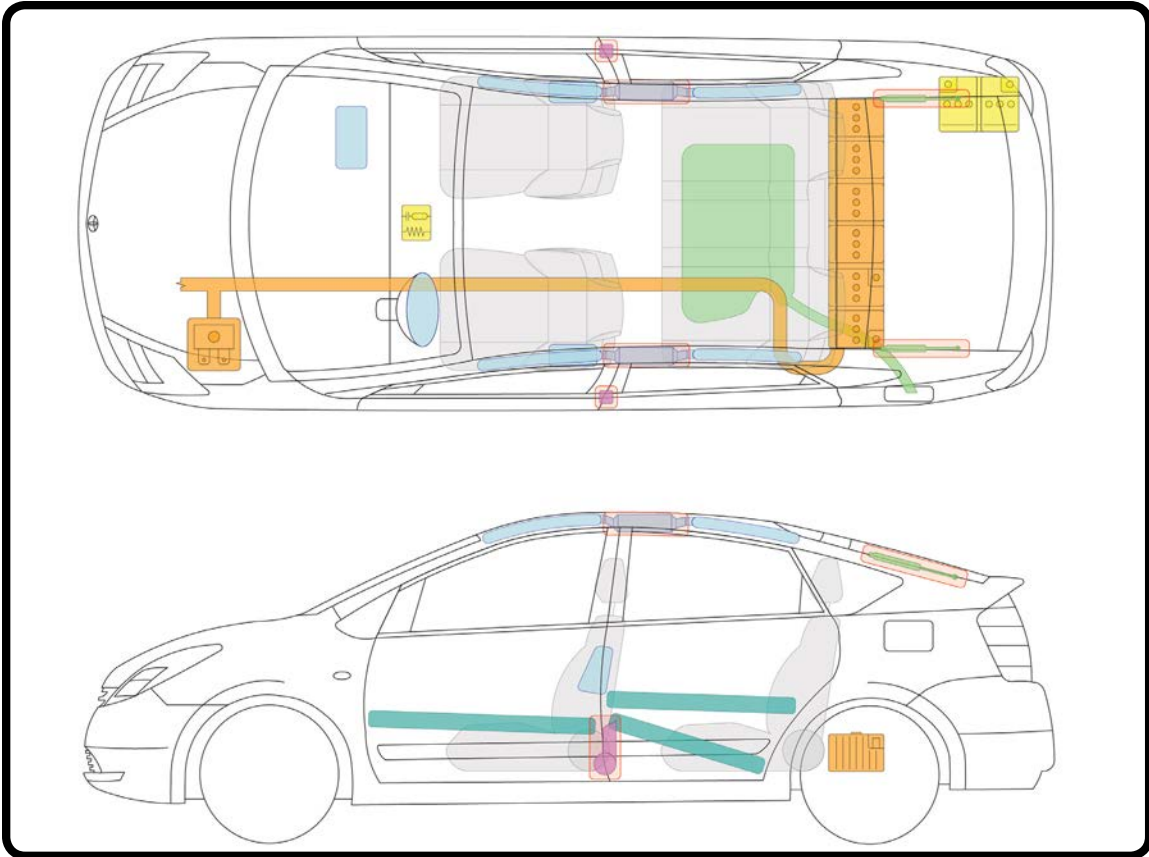

TOYOTA
PRIUS

TOYOTA

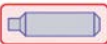
(continued) **EXTRICATION INFORMATION**

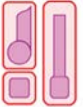

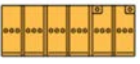
LEGEND

 Airbag	 Bodywork Reinforcements	 SRS Control Unit
 Stored Gas Inflator	 Support Cylinder for Hood	 12V Battery
 Seatbelt Tensioner or Pretensioner	 Fuel Tank	 High-Voltage Power Cable
 High-Voltage Battery	 Emergency Disconnect (Remove Fuse)	

For towing and post-incident instructions, see the **POST-INCIDENT** section on page 20.

TOYOTA



2010-15

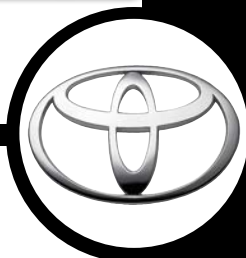

HYBRID

VEHICLE INFORMATION

IMMOBILIZE VEHICLE

1. Chock the wheels.
2. Set parking brake. (foot pedal)
3. Place vehicle into park. (push-button, above gear selector)

DISABLE VEHICLE

Determine if vehicle is ON by illumination of READY light.

PRIMARY PROCEDURE

1. If ON, shut off ignition (push-button, right of instrument panel). Remove proximity key and keep it at least 16 feet (5 meters) from vehicle.
2. Disconnect 12V battery (cargo area right side).

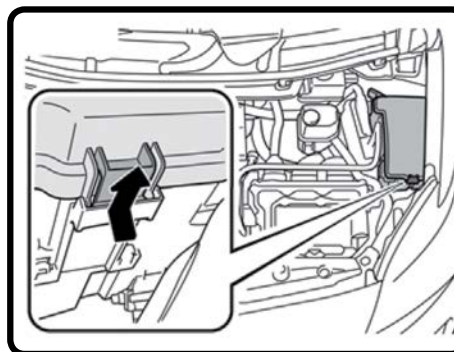

Remove Fuse Box Cover

ALTERNATE PROCEDURE





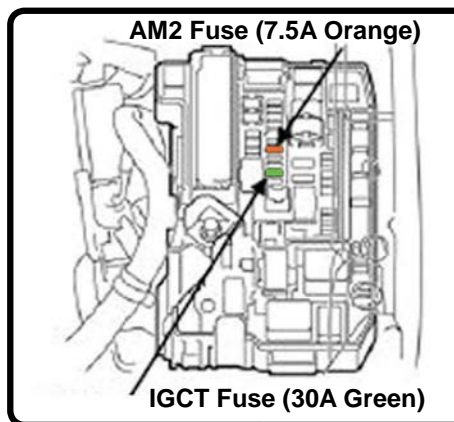

(if power button is inaccessible)

1. Remove engine compartment fuse box cover (driver's side).
2. Remove IGCT fuse (30A green) and AM2 fuse (7.5A orange) from the fuse box. If correct fuses cannot be identified, pull all fuses in fuse box.
3. Disconnect 12V auxiliary battery (cargo area right side).



IGCT and AM2 Fuse Location In Engine Compartment Fuse Box

WARNINGS

-  NEVER cut, breach, or touch high voltage components or cabling. Doing so could result in serious injury or death.
-  The high voltage system may remain powered for up to 10 minutes after shutoff/disabling. Avoid touching, cutting, or opening any orange high voltage cable or component.
-  Airbags and SRS may remain powered for up to 90 seconds after shutoff/disabling. Avoid breaching SRS components.
-  High voltage system may be energized if vehicle is OFF, but remote air conditioning system is active. Blower fan noise may be heard if system is ON.
-  Vehicle may be equipped with a 27V DC solar panel in the roof. See the following 2 pages for details. 27V cable has a higher arc potential than 12V wires.
-  Lack of engine noise does not mean vehicle is OFF. Silent movement or instant restart capability exists until vehicle is fully shut down.

TOYOTA

TOYOTA

PRIUS

HEV











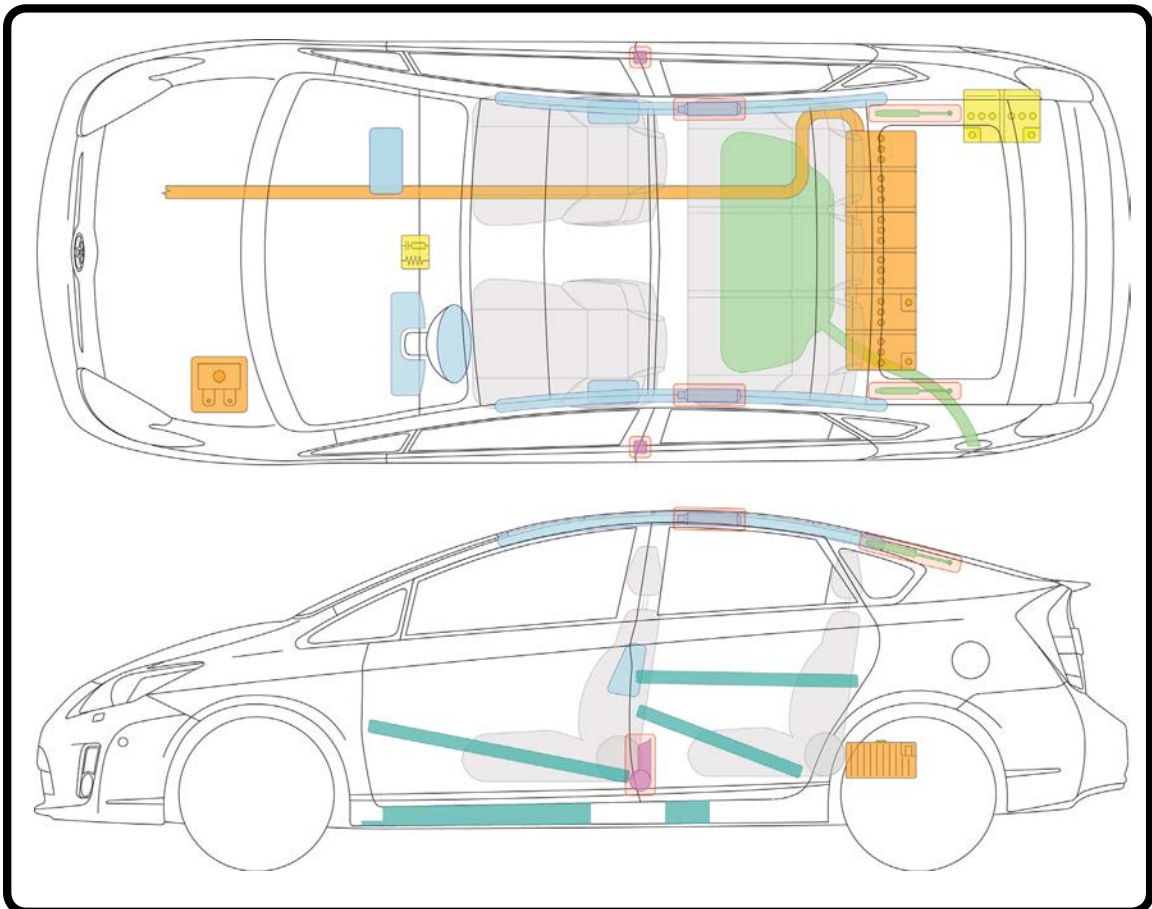

2010-15

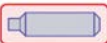

TOYOTA
PRIUS
TOYOTA

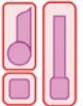
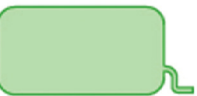
(continued) **EXTRICATION INFORMATION**

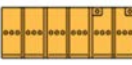

LEGEND		
 Airbag	 Bodywork Reinforcements	 SRS Control Unit
 Stored Gas Inflator	 Support Cylinder for Hood	 12V Battery
 Seatbelt Tensioner or Pretensioner	 Fuel Tank	 High-Voltage Power Cable
 High-Voltage Battery	 Emergency Disconnect (Remove Fuse)	

For towing and post-incident instructions, see the **POST-INCIDENT** section on page 20.



2010-15

HYBRID

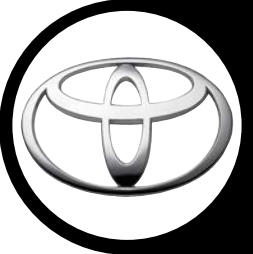

VEHICLE INFORMATION

SPECIAL CONCERNS

ROOF REMOVAL WITH SOLAR PANEL (OPTIONAL)

- Prius models equipped with the optional solar panel have an output wire bundled with the side curtain airbag wire harness, routed along the driver's side (C) pillar.
- This output wire is energized when the solar panel surface is exposed to light energy. Do not cut the shaded area until disabling the 27V solar panel.

 Cutting the roof center section may result in cutting into the optional solar panel and energized output wire. The solar panel output wire has a high arc potential.

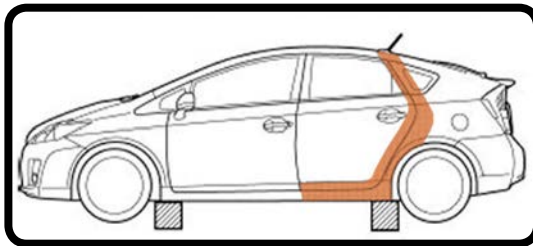

Before cutting the shaded area, disable the solar panel.

Disabling the 27V Solar Panel

There is an optional 27V solar panel located on the rear portion of the roof.

 The solar panel output wire is not electrically connected to the 12V auxiliary battery, SRS airbags, or the high voltage (HV) battery. The solar panel output will not back feed power to these circuits.

OPTION 1

1. Remove the headliner above the driver's side rear passenger area.
2. Identify the red or blue output wire from under the solar panel.
3. Disconnect the connector or cut the red or blue wire to disable power output.

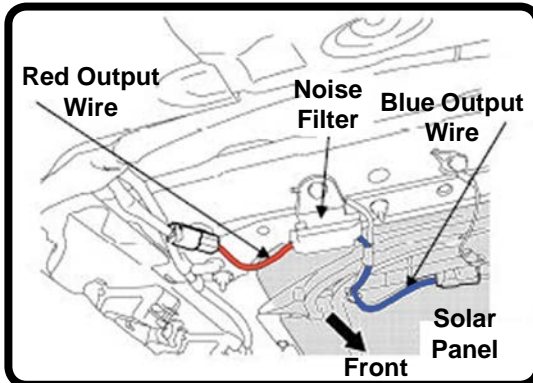

Option 1: Disconnect or cut red or blue output wire.

OPTION 2

1. Disable solar panel output by covering the entire panel with a material that blocks sunlight.
2. Either use two separate layers or one layer folded over the other.

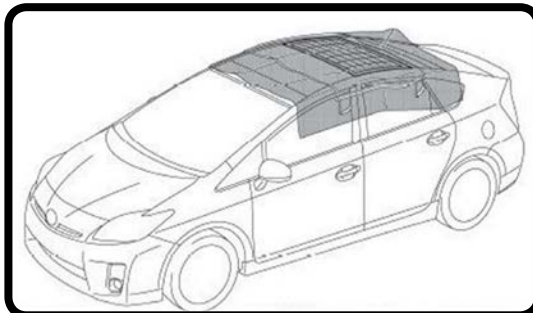

Disable by covering the entire solar panel.

 Even a small amount of sunlight will allow the solar panel to generate power. Once the solar panel is disabled, the output in the energized wire drops immediately.

For towing and post-incident instructions, see the **POST-INCIDENT** section on page 20.

TOYOTA

TOYOTA

PRIUS

HEV



2010-15



TOYOTA

PRIUS

TOYOTA

THIS PAGE INTENTIONALLY LEFT BLANK



2016-18

HYBRID



VEHICLE INFORMATION

Li-ion

See pages 15, 22.

IMMOBILIZE VEHICLE

1. **Chock the wheels.**
2. **Set parking brake.**
(foot pedal)
3. **Place vehicle into park.**
(push-button, center console)

DISABLE VEHICLE

Determine if vehicle is ON by illumination of READY light.

PRIMARY PROCEDURE

1. If ON, shut off ignition (push-button, right of instrument panel).
2. Remove proximity key and keep it at least 16 feet (5 meters) from vehicle.
3. Disconnect negative 12V battery cable (engine compartment, driver's side).

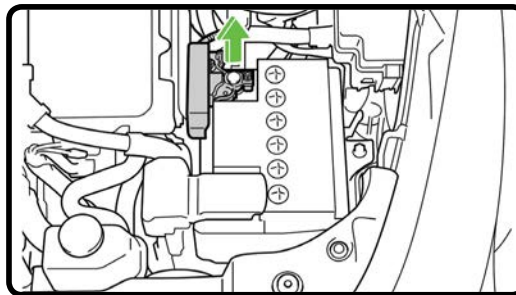

12V Battery Engine Compartment

ALTERNATE PROCEDURE



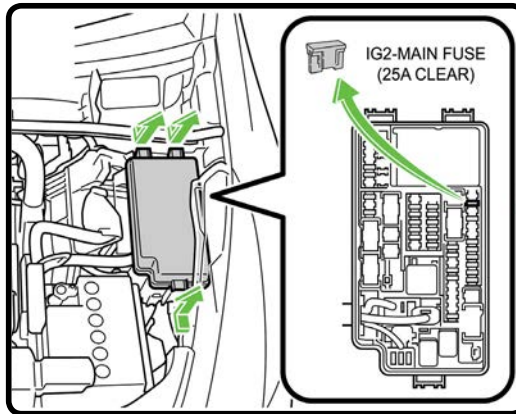

(if power button is inaccessible)

1. Open hood and remove engine compartment fuse box cover (driver's side).
2. Remove IG2 fuse (25A clear) from the fuse box. If the correct fuse cannot be identified, pull all fuses in fuse box.
3. Disconnect negative 12V battery cable (engine compartment, driver's side).



Remove Fuse IG2 in Engine Compartment

WARNINGS

-  NEVER cut, breach, or touch high voltage components or cabling. Doing so could result in serious injury or death.
-  The high voltage system may remain powered for up to 10 minutes after shutoff/disabling. Avoid touching, cutting, or opening any orange high voltage cable or component.
-  Airbags and SRS may remain powered for up to 90 seconds after shutoff/disabling. Avoid breaching SRS components.
-  Lack of engine noise does not mean vehicle is OFF. Silent movement or instant restart capability exists until vehicle is fully shut down.

TOYOTA

TOYOTA

PRIVUS

HEV



2016-18



Li-ion (continued) **EXTRICATION INFORMATION**

See pages 15, 22.

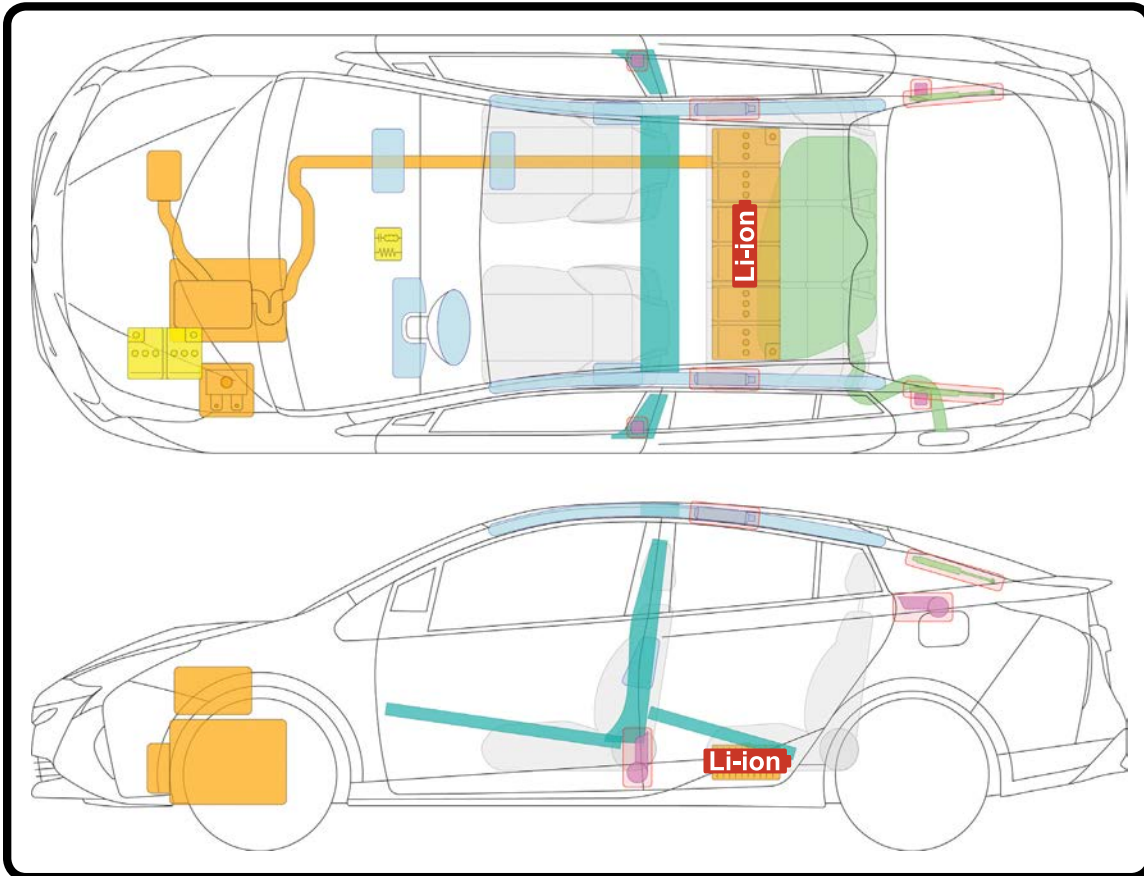

LEGEND		
Airbag	Bodywork Reinforcements	SRS Control Unit
Stored Gas Inflator	Support Cylinder for Hood	12V Battery
Seatbelt Tensioner or Pretensioner	Fuel Tank	High-Voltage Power Cable
High-Voltage Battery	Emergency Disconnect (Remove Fuse)	

For towing and post-incident instructions, see the **POST-INCIDENT** section on page 20.

TOYOTA **PRIUS**



2012-14

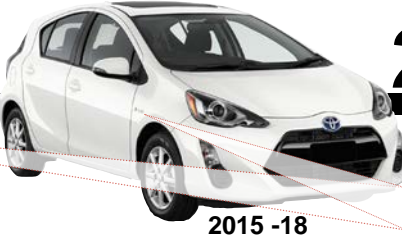

2015 -18

2012-18

HYBRID



VEHICLE INFORMATION

IMMOBILIZE VEHICLE

1. **Chock the wheels.**
2. **Set parking brake.**
(hand brake, center console)
3. **Place vehicle into park.**
(gear selector, center console)

DISABLE VEHICLE

Determine if vehicle is ON by illumination of READY indicator.

PRIMARY PROCEDURE

1. If ON, shut off ignition (key, steering column; or push-button, right of instrument panel). Remove proximity key (if equipped) and keep it at least 16 feet (5 meters) from vehicle.
2. Disconnect 12V battery (under passenger's side rear seat).

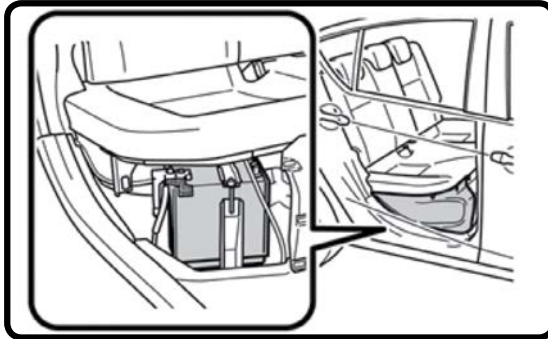

12V Auxiliary Battery

ALTERNATE PROCEDURE



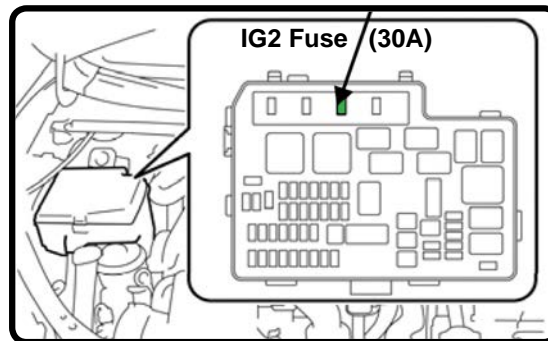

(if power button is inaccessible)

1. Open hood and remove engine compartment fuse box cover (passenger's side).
2. Remove IG2 fuse (30A green) from the fuse box. If the correct fuse cannot be identified, pull all fuses in fuse box.
3. Disconnect 12V battery (under passenger's side rear seat).



IG2 Fuse Location in Engine Compartment Fuse Box

WARNINGS

-  NEVER cut, breach, or touch high voltage components or cabling. Doing so could result in serious injury or death.
-  The high voltage system may remain powered for up to 10 minutes after the vehicle is shut off.
-  The SRS system (airbags, etc.) may remain powered for up to 90 seconds after disabling.
-  There is a 27V AC Electric Power Steering (EPS) system behind the instrument cluster and routed a short distance along the steering column. 27V AC has a higher arc potential than 12V DC.
-  Lack of engine noise does not mean vehicle is OFF. Silent movement or instant restart capability exists until vehicle is fully shut down.

TOYOTA

TOYOTA

PRIVUSC

HEV



2012-18











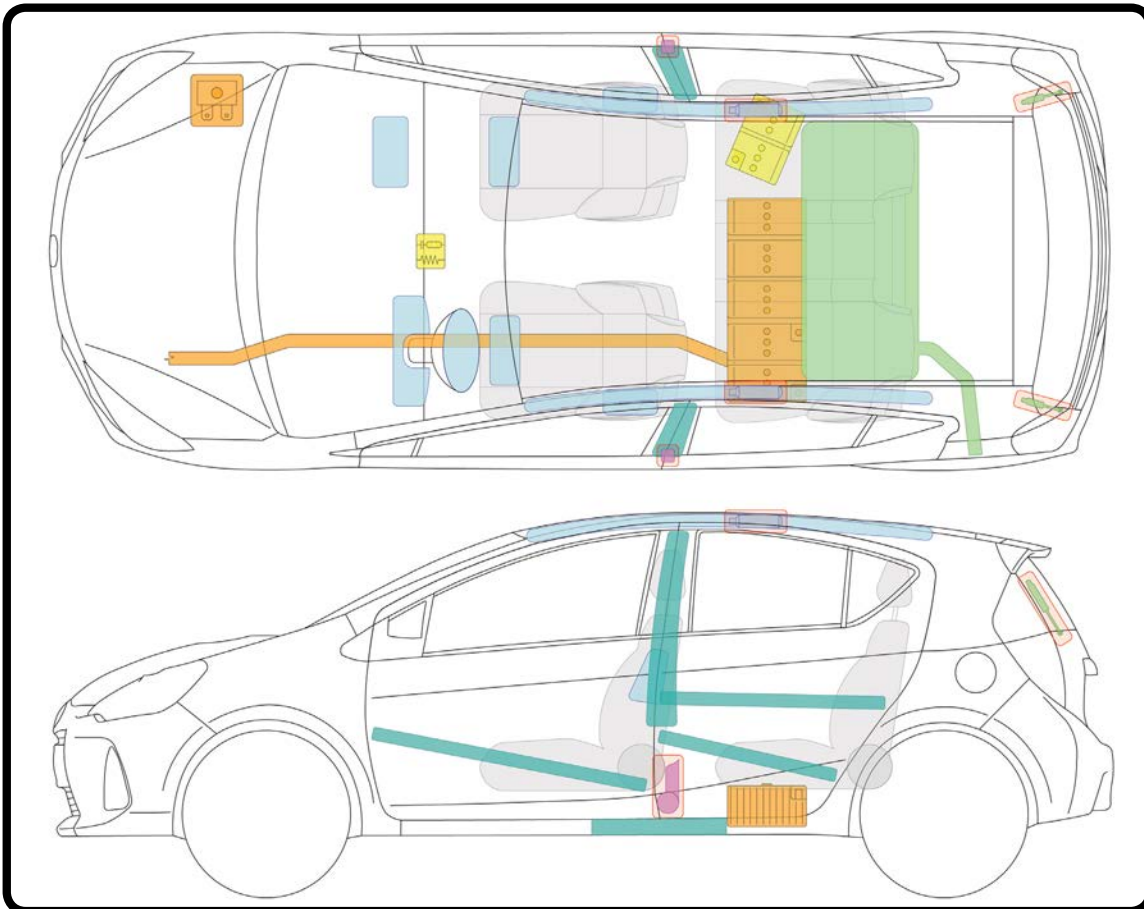

2012-14

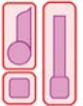

2015-18

(continued) **EXTRICATION INFORMATION**

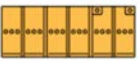

LEGEND		
 Airbag	 Bodywork Reinforcements	 SRS Control Unit
 Stored Gas Inflator	 Support Cylinder for Hood	 12V Battery
 Seatbelt Tensioner or Pretensioner	 Fuel Tank	 High-Voltage Power Cable
 High-Voltage Battery	 Emergency Disconnect (Remove Fuse)	

For towing and post-incident instructions, see the **POST-INCIDENT** section on page 20.

TOYOTA **PRIUS**



2010

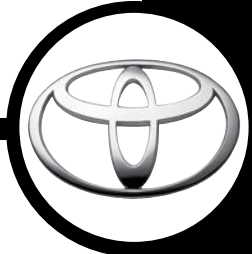

PLUG-IN HYBRID

VEHICLE INFORMATION

Li-ion

See pages 15, 22.

NOTE: The 2010 Prius Plug-in is a limited-production demonstration model. It can be identified by the charging port on the front left fender. (The 2012+ production version's charging port is on the right rear fender.)

IMMOBILIZE VEHICLE

1. **Chock the wheels.**
2. **Set parking brake.**
(foot pedal)
3. **Place vehicle into park.**
(push-button, above gear selector)

DISABLE VEHICLE

Determine if vehicle is ON by illumination of READY light.

If vehicle is plugged into a charging station, disconnect charge cable and close the charge inlet cap and door, if it is safe to do so.

PRIMARY PROCEDURE

1. If ON, shut off ignition (push-button, right of instrument panel). Remove proximity key and keep it at least 16 feet (5 meters) from vehicle.
2. Disconnect 12V battery (cargo area right side).

ALTERNATE PROCEDURE

(if power button is inaccessible)

1. Remove engine compartment fuse box cover (driver's side).
2. Remove IGCT fuse (30A green) and AM2 fuse (7.5A brown) from the fuse box. If correct fuses cannot be identified, pull all fuses in fuse box.
3. Disconnect 12V auxiliary battery (cargo area right side).

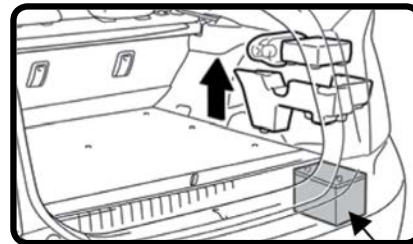

12V Auxiliary Battery

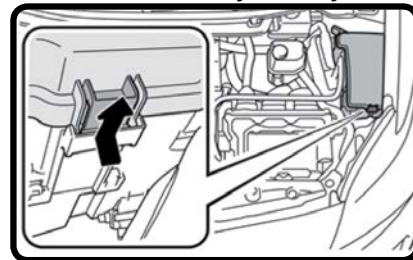

Remove Fuse Box Cover

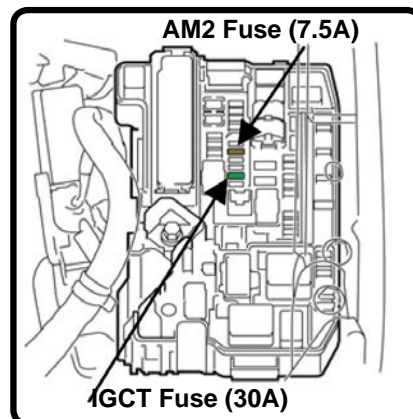

IGCT and AM2 Fuse Location in Engine Compartment Fuse Box

WARNINGS (continued on the next page)



NEVER cut, breach, or touch high voltage components or cabling. Doing so could result in serious injury or death.



The high voltage system may remain powered for up to 10 minutes after shutoff/disabling. Avoid touching, cutting, or opening any orange high voltage cable or component.

TOYOTA

TOYOTA

PRIVUS PLUG-IN



2010



TOYOTA

TOYOTA PRIUS PLUG-IN

Li-ion

See pages 15, 22.

(continued)

EXTRICATION INFORMATION

WARNINGS (continued)

- Airbags and SRS may remain powered for up to 90 seconds after shutoff/disabling. Avoid breaching SRS components.
- High voltage system may be energized if vehicle is OFF, but remote air conditioning system is active. Blower fan noise may be heard if system is ON.
- In the event of a fire involving a charging station, reference the **FIRE** portion of this guide, and treat it as an energized electrical fire until power to the charger can be shut down.
- Lack of engine noise does not mean vehicle is OFF. Silent movement or instant restart capability exists until vehicle is fully shut down.

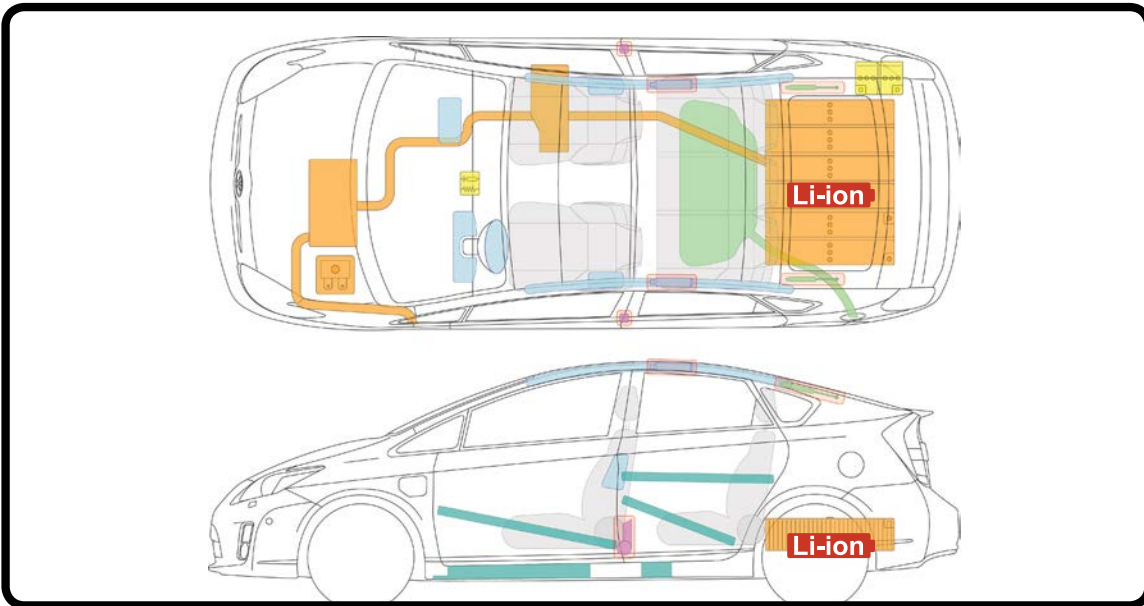

LEGEND

	Airbag		Bodywork Reinforcements		SRS Control Unit
	Stored Gas Inflator		Support Cylinder for Hood		12V Battery
	Seatbelt Tensioner or Pretensioner		Fuel Tank		High-Voltage Power Cable
	High-Voltage Battery		Emergency Disconnect (Remove Fuse)		

For towing and post-incident instructions, see the **POST-INCIDENT** section on page 20.



2012-15

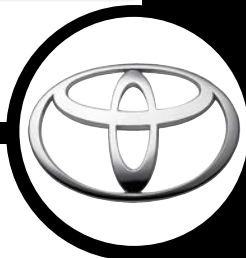

PLUG-IN HYBRID

VEHICLE INFORMATION

Li-ion

See pages 15, 22.

NOTE: The 2012+ production version's charging port is on the right rear fender. The 2010 Prius Plug-in is a limited-production demonstration model that can be identified by the charging port on the front left fender.

IMMOBILIZE VEHICLE

1. Chock the wheels.
2. Set parking brake. (foot pedal)
3. Place vehicle into park. (push-button, above gear selector)

DISABLE VEHICLE

Determine if vehicle is ON by illumination of READY light.

If vehicle is plugged into a charging station, disconnect charge cable and close the charge inlet cap and door, if it is safe to do so.

PRIMARY PROCEDURE

1. If ON, shut off ignition (push-button, right of instrument panel). Remove proximity key and keep it at least 16 feet (5 meters) from vehicle.
2. Disconnect 12V battery (cargo area right side, beneath panel).

ALTERNATE PROCEDURE

(if power button is inaccessible)

1. Open hood and remove engine compartment fuse box cover (driver's side).
2. Remove IG2 fuse (20A yellow) from the fuse box. If the correct fuse cannot be identified, pull all fuses in fuse box.
3. Disconnect 12V battery (cargo area right side, beneath panel).

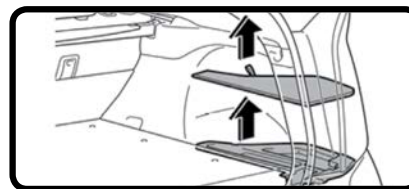

Remove Deck Board

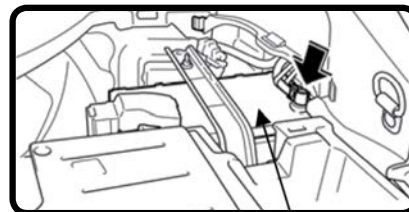

12V Auxiliary Battery

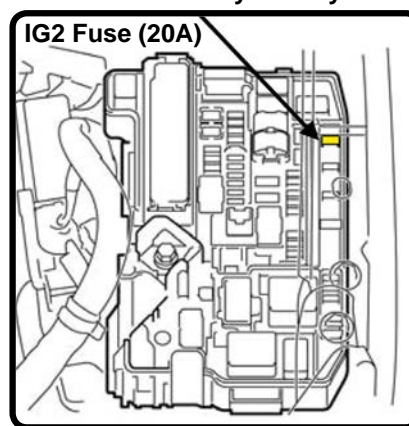

IG2 Fuse Location in Engine Compartment Fuse Box

WARNINGS (continued on the next page)



NEVER cut, breach, or touch high voltage components or cabling. Doing so could result in serious injury or death.



The high voltage system may remain powered for up to 10 minutes after the vehicle is shut off.



The SRS system (airbags, etc.) may remain powered for up to 90 seconds after disabling.



High voltage system may be energized if vehicle is OFF, but remote air conditioning system is active. Blower fan noise may be heard if system is ON.

TOYOTA

TOYOTA

PRIVUS PLUG-IN



2012-15



TOYOTA
PRIUS PLUG-IN

Li-ion (continued) **EXTRICATION INFORMATION**

See pages 15, 22.

WARNINGS (continued)

- In the event of a fire involving a charging station, reference the **FIRE** portion of this guide, and treat it as an energized electrical fire until power to the charger can be shut down.
- Lack of engine noise does not mean vehicle is OFF. Silent movement or instant restart capability exists until vehicle is fully shut down.

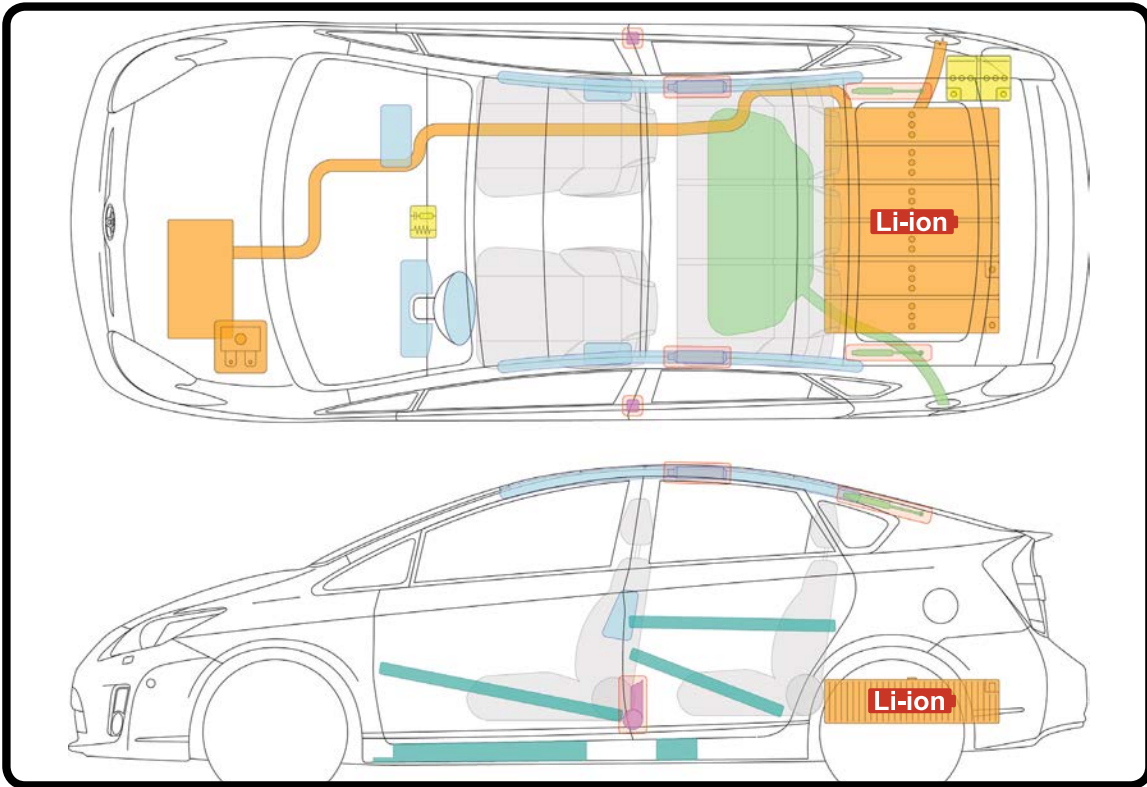

LEGEND		
Airbag	Bodywork Reinforcements	SRS Control Unit
Stored Gas Inflator	Support Cylinder for Hood	12V Battery
Seatbelt Tensioner or Pretensioner	Fuel Tank	High-Voltage Power Cable
High-Voltage Battery	Emergency Disconnect (Remove Fuse)	

For towing and post-incident instructions, see the **POST-INCIDENT** section on page 20.



2017-18

PLUG-IN HYBRID

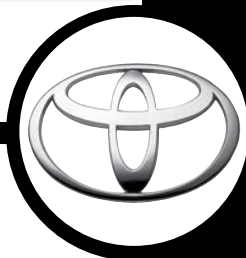

VEHICLE INFORMATION

Li-ion

See pages 15, 22.

IMMOBILIZE VEHICLE

1. **Chock the wheels.**
2. **Set parking brake.**
(foot pedal)
3. **Place vehicle into park.**
(push-button, center console)

DISABLE VEHICLE

Determine if vehicle is ON by illumination of instrument panel.

PRIMARY PROCEDURE

1. If ON, shut off ignition (push-button, right of instrument panel).
2. Remove proximity key and keep it at least 16 feet (5 meters) from vehicle.
3. Disconnect negative 12V battery cable (engine compartment, driver's side).

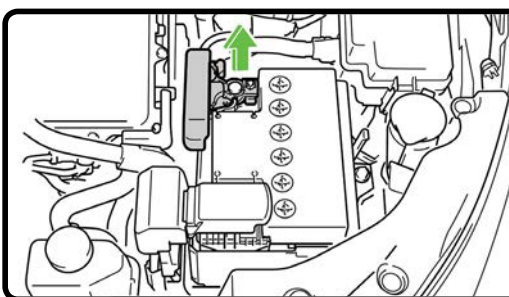

12V Battery Engine Compartment

ALTERNATE PROCEDURE

(if power button is inaccessible)

1. Open hood and remove engine compartment fuse box cover (driver's side).
2. Remove IG2 fuse (25A clear) from the fuse box. If the correct fuse cannot be identified, pull all fuses in fuse box.
3. Disconnect negative 12V battery cable (engine compartment, driver's side).

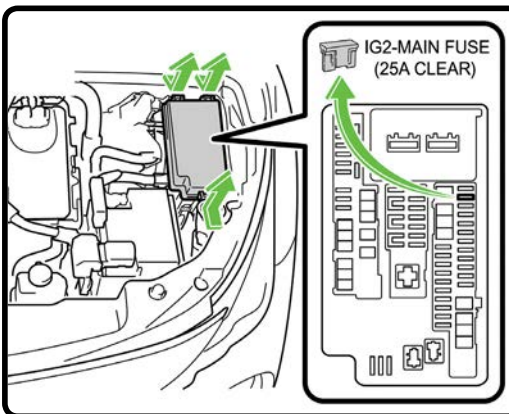

Remove Fuse IG2 in Engine Compartment

WARNINGS

- NEVER cut, breach, or touch high voltage components or cabling. Doing so could result in serious injury or death.
- The high voltage system may remain powered for up to 10 minutes after shutoff/disabling. Avoid touching, cutting, or opening any orange high voltage cable or component.
- Airbags and SRS may remain powered for up to 90 seconds after shutoff/disabling. Avoid breaching SRS components.
- In the event of a fire involving a charging station, reference the **FIRE** portion of this guide, and treat it as an energized electrical fire until power to the charger can be shut down.
- Lack of engine noise does not mean vehicle is OFF. Silent movement or instant restart capability exists until vehicle is fully shut down.

TOYOTA

TOYOTA

PRIMUS PRIME



2017-18







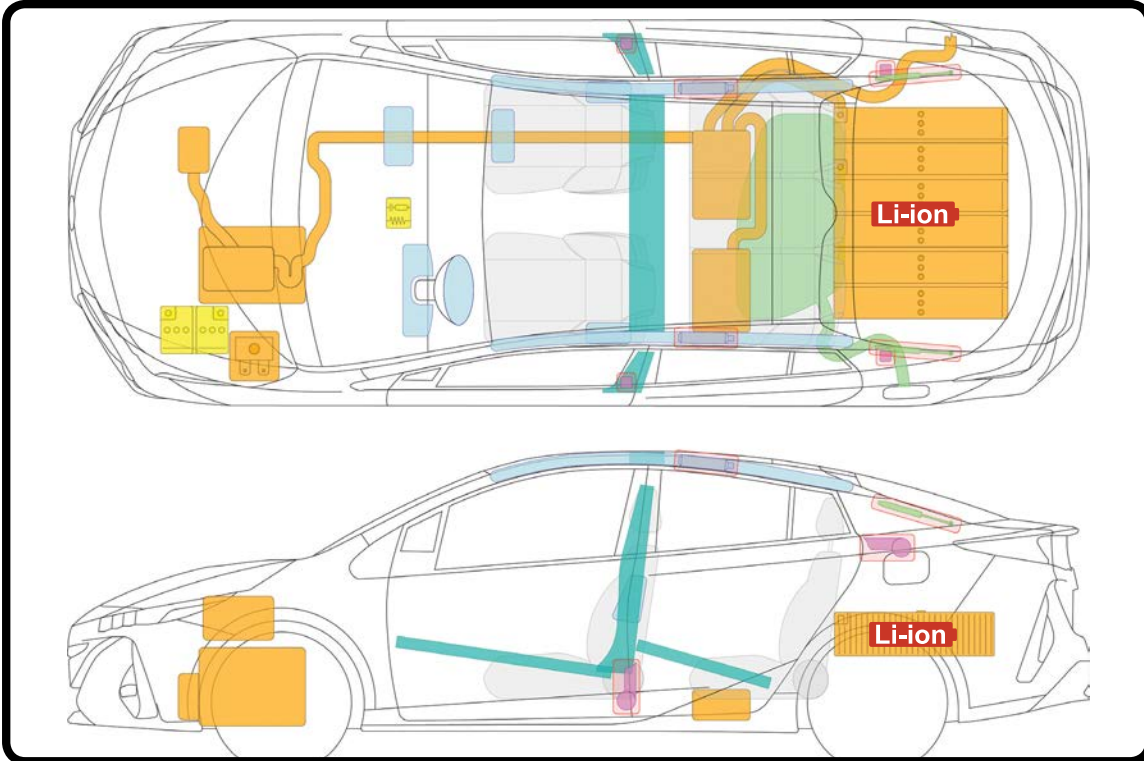

PRIME

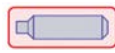

Li-ion (continued) **EXTRICATION INFORMATION**

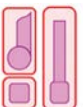
See pages 15, 22.



LEGEND		
 Airbag	 Bodywork Reinforcements	 SRS Control Unit
 Stored Gas Inflator	 Support Cylinder for Hood	 12V Battery
 Seatbelt Tensioner or Pretensioner	 Fuel Tank	 High-Voltage Power Cable
 High-Voltage Battery	 Emergency Disconnect (Remove Fuse)	

For towing and post-incident instructions, see the **POST-INCIDENT** section on page 20.



2012-14



2015-18

2012-18

HYBRID

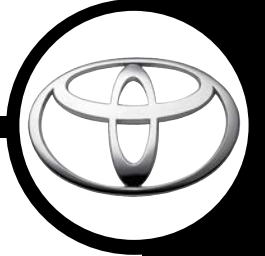

VEHICLE INFORMATION

Li-ion

See pages 15, 22.

IMMOBILIZE VEHICLE

1. **Chock the wheels.**
2. **Set parking brake.**
(foot pedal)
3. **Place vehicle into park.**
(push-button, above gear selector)

DISABLE VEHICLE

Determine if vehicle is ON by illumination of READY indicator.

PRIMARY PROCEDURE

1. If ON, shut off ignition (push-button, right of instrument panel). Remove proximity key and keep it at least 16 feet (5 meters) from vehicle.
2. Disconnect 12V battery (cargo area right side, beneath panel).

ALTERNATE PROCEDURE

(if power button is inaccessible)

1. Open hood and remove engine compartment fuse box cover (driver's side).
2. Remove IG2 fuse (20A yellow) from the fuse box. If the correct fuse cannot be identified, pull all fuses in fuse box.
3. Disconnect 12V battery (cargo area right side, beneath panel).

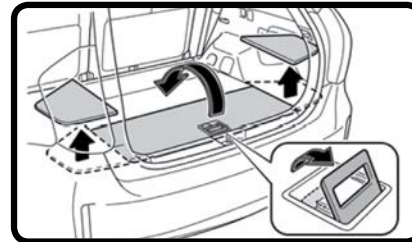

Remove Deck Board



12V Auxiliary Battery

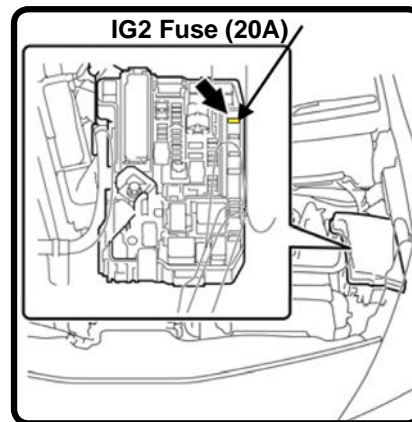

IG2 Fuse Location in Engine Compartment Fuse Box

WARNINGS (continued on the next page)



NEVER cut, breach, or touch high voltage components or cabling. Doing so could result in serious injury or death.



The high voltage system may remain powered for up to 10 minutes after the vehicle is shut off.



The SRS system (airbags, etc.) may remain powered for up to 90 seconds after disabling.

TOYOTA

TOYOTA

PRIVUS



2012-18



2012-14

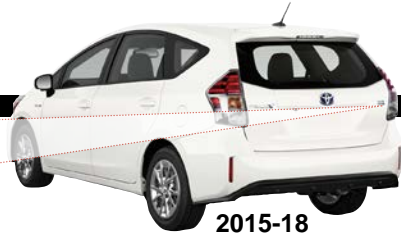

2015-18

Li-ion (continued) **EXTRICATION INFORMATION**

See pages 15, 22.

WARNINGS (continued)

- There is a 27V AC Electric Power Steering (EPS) system behind the instrument cluster and routed a short distance along the steering column. 27V AC has a higher arc potential than 12V DC.
- Lack of engine noise does not mean vehicle is OFF. Silent movement or instant restart capability exists until vehicle is fully shut down.

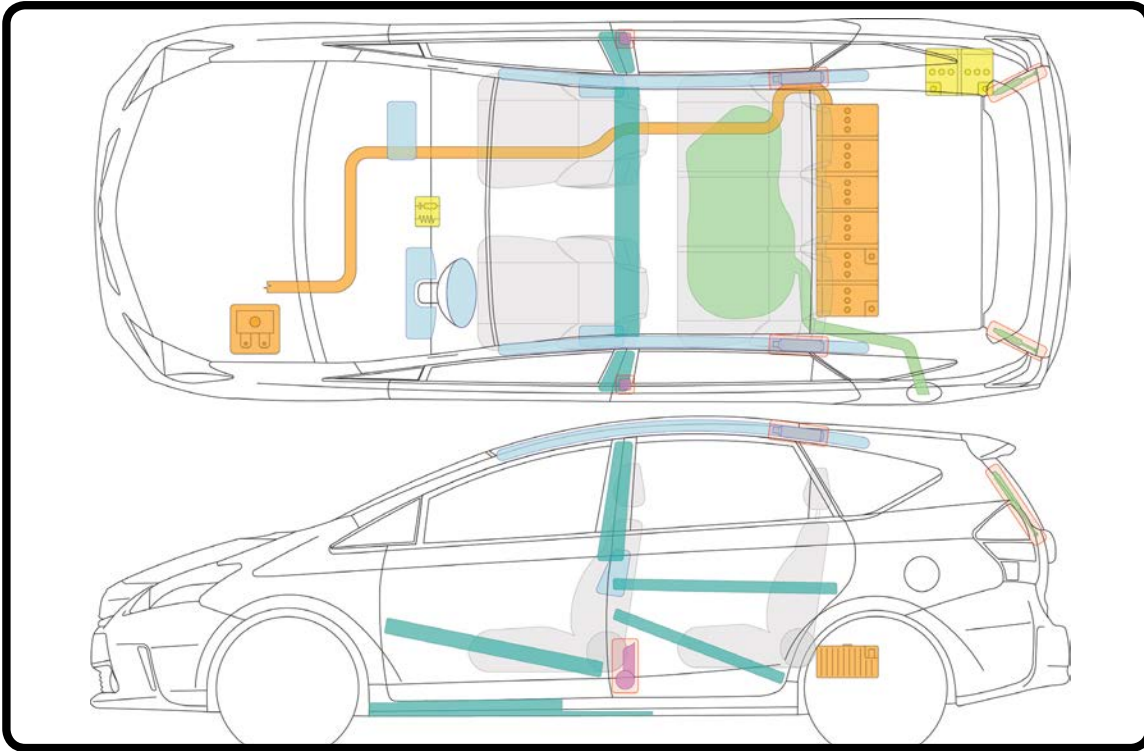

LEGEND

Airbag	Bodywork Reinforcements	SRS Control Unit
Stored Gas Inflator	Support Cylinder for Hood	12V Battery
Seatbelt Tensioner or Pretensioner	Fuel Tank	High-Voltage Power Cable
High-Voltage Battery	Emergency Disconnect (Remove Fuse)	

For towing and post-incident instructions, see the **POST-INCIDENT** section on page 20.

TOYOTA **PRIVUS** **TOYOTA**



2012-14

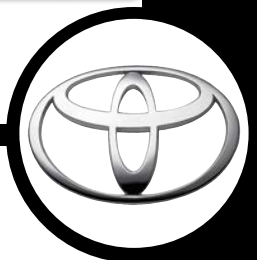

VEHICLE INFORMATION

Li-ion

See pages 15, 22.

IMMOBILIZE VEHICLE

1. **Chock the wheels.**
2. **Set parking brake.**
(hand brake, center console)
3. **Place vehicle into park.**
(center console, button)

DISABLE VEHICLE

Determine if vehicle is ON by illumination of READY light.

If the charge cable assembly is connected, disconnect by pushing the lock release button on the top of the connector and remove (quick charge connectors may not have a release button).

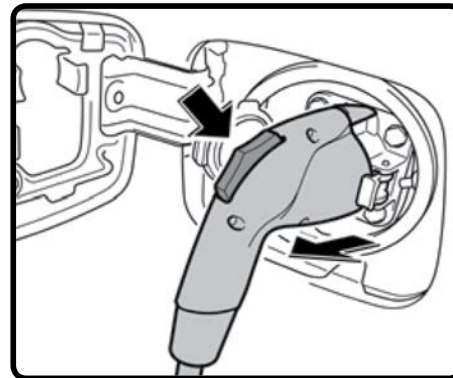

Disconnect Charging Cable

PRIMARY PROCEDURE

1. If ON, shut off ignition (push-button, right of instrument panel). Remove proximity key and keep it at least 16 feet (5 meters) from vehicle.
2. Disconnect 12V battery (engine compartment, drivers side).

ALTERNATE PROCEDURE



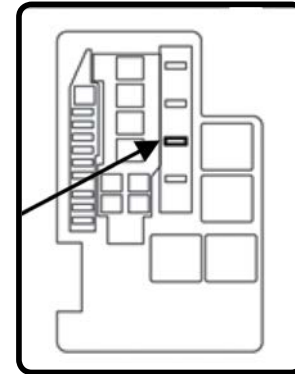

(if power button is inaccessible)

1. Remove under the hood fuse box cover (driver's side).
2. Remove IG2 fuse (15A blue) from the engine compartment fuse box. If the correct fuse cannot be identified, pull all of the fuses in box.
3. Disconnect 12V battery (engine compartment, drivers side)



Remove Fuse IG2 (15A blue)

WARNINGS

-  NEVER cut, breach, or touch high voltage components or cabling. Doing so could result in serious injury or death.
-  The high voltage system may remain powered for up to 10 minutes after shutoff/disabling. Avoid touching, cutting, or opening any orange high voltage cable or component.
-  Airbags and SRS may remain powered for up to 90 seconds after shutoff/disabling. Avoid breaching SRS components.
-  In the event of a fire involving a charging station, reference the **FIRE** portion of this guide, and treat it as an energized electrical fire until power to the charger can be shut down.
-  This vehicle does not have an internal combustion engine. Lack of engine noise does not mean vehicle is OFF. Silent movement capability exists until vehicle is fully shut down.

TOYOTA

TOYOTA

RAV4 EV

EV



2012-14









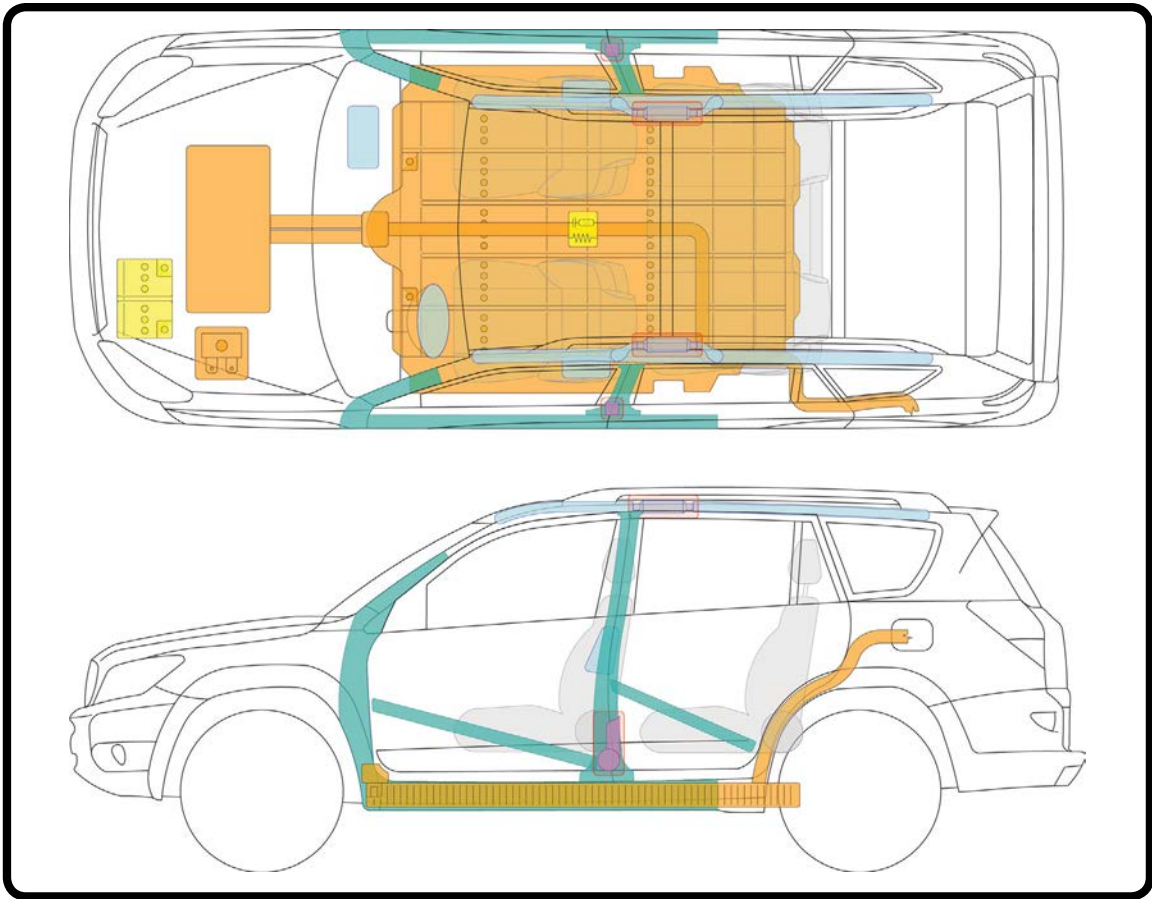



ELECTRIC

Li-ion (continued) **EXTRICATION INFORMATION**

See pages 15, 22.

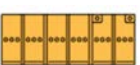

LEGEND		
 Airbag	 Bodywork Reinforcements	 SRS Control Unit
 Stored Gas Inflator	 Support Cylinder for Hood	 12V Battery
 Seatbelt Tensioner or Pretensioner		 High-Voltage Power Cable
 High-Voltage Battery	 Emergency Disconnect (Remove Fuse)	

For towing and post-incident instructions, see the **POST-INCIDENT** section on page 20.

TOYOTA RAV4 EV

TOYOTA



2016-18

HYBRID



TOYOTA

TOYOTA

RAV4

VEHICLE INFORMATION

IMMOBILIZE VEHICLE

1. **Chock the wheels.**
2. **Set parking brake.**
(hand brake, center console)
3. **Place vehicle into park.**
(gear selector, center console)

DISABLE VEHICLE

Determine if vehicle is ON by illumination of READY light.

PRIMARY PROCEDURE

1. If ON, shut off ignition (push-button, right of instrument panel).
2. Remove proximity key and keep it at least 16 feet (5 meters) from vehicle.
3. Disconnect negative 12V battery cable (under luggage compartment, left side).

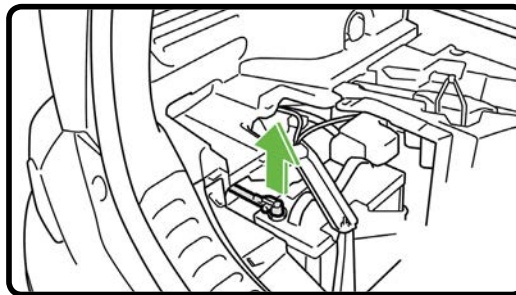

12V Battery in Luggage Compartment

ALTERNATE PROCEDURE



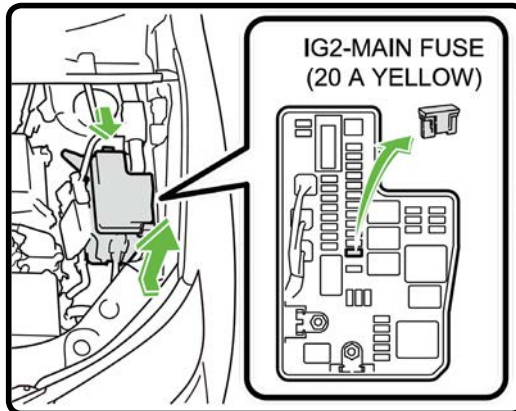

(if power button is inaccessible)

1. Open hood and remove engine compartment fuse box cover (driver's side).
2. Remove IG2 fuse (20A yellow) from the fuse box. If the correct fuse cannot be identified, pull all fuses in fuse box.
3. Disconnect negative 12V battery cable (under luggage compartment, left side).



Remove Fuse IG2 in Engine Compartment

WARNINGS

-  NEVER cut, breach, or touch high voltage components or cabling. Doing so could result in serious injury or death.
-  The high voltage system may remain powered for up to 10 minutes after shutoff/disabling. Avoid touching, cutting, or opening any orange high voltage cable or component.
-  Airbags and SRS may remain powered for up to 90 seconds after shutoff/disabling. Avoid breaching SRS components.
-  Lack of engine noise does not mean vehicle is OFF. Silent movement or instant restart capability exists until vehicle is fully shut down.

HEV



2016-18

HYBRID









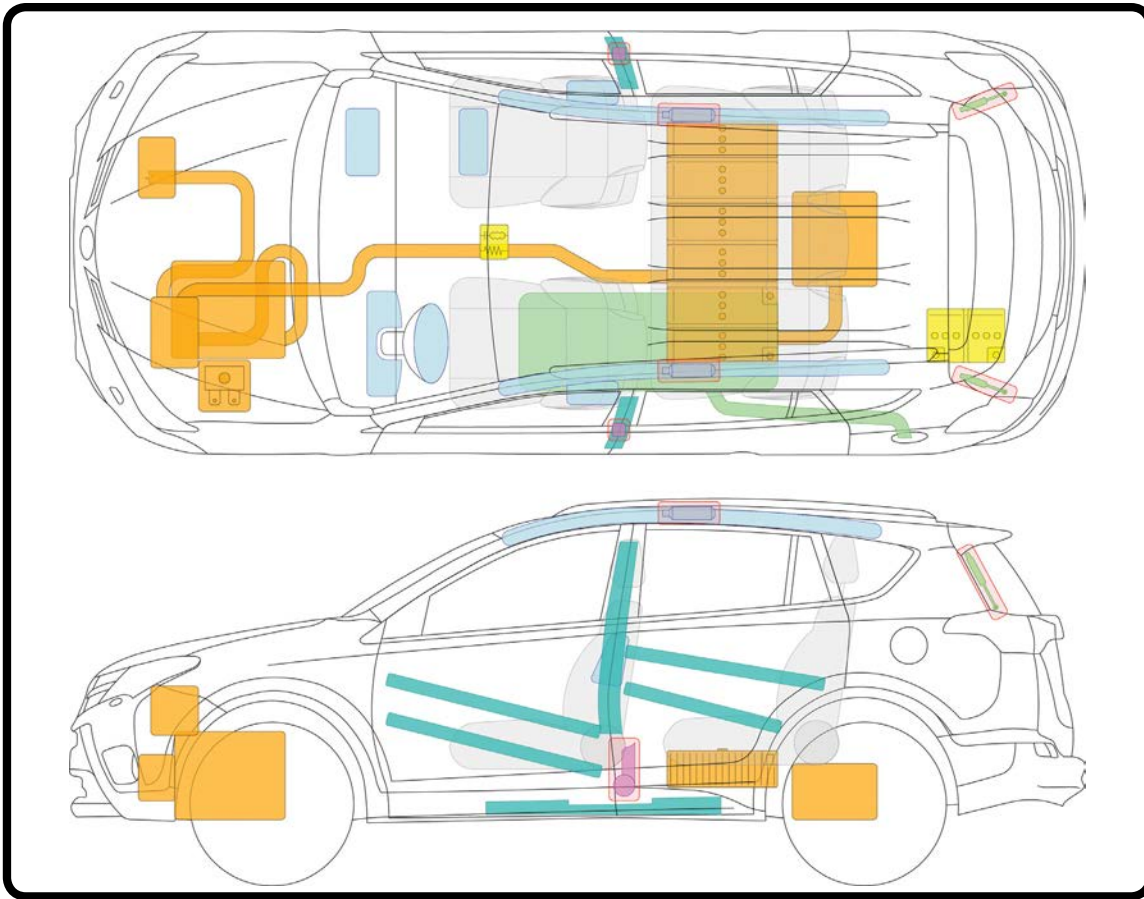



RAV4

TOYOTA

(continued) **EXTRICATION INFORMATION**

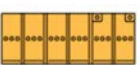

LEGEND		
 Airbag	 Bodywork Reinforcements	 SRS Control Unit
 Stored Gas Inflator	 Support Cylinder for Hood	 12V Battery
 Seatbelt Tensioner or Pretensioner	 Fuel Tank	 High-Voltage Power Cable
 High-Voltage Battery	 Emergency Disconnect (Remove Fuse)	

For towing and post-incident instructions, see the **POST-INCIDENT** section on page 20.

TOYOTA



2010-14



VEHICLE INFORMATION

See page 24.

IMMOBILIZE VEHICLE

- 1. **Chock the wheels.**
- 2. **Set parking brake.**
(yellow diamond shaped lever, left console)
- 3. **Place vehicle into park.**
(center console)

DISABLE VEHICLE

PRIMARY PROCEDURE

- 1. Turn master run switch (A) to OFF position (driver's left panel).
- 2. Turn 24V battery switch to OFF position (C) by turning a quarter turn counterclockwise (located in the outside compartment at the front of the bus on the left hand side, directly below drivers window).

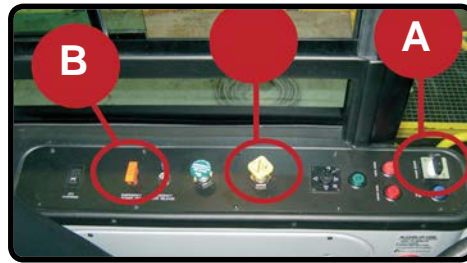

Driver's Left Panel

ALTERNATE PROCEDURE #1 (if driver's panel is inaccessible)

- 1. Open orange switch guard labeled "Emergency Power OFF" (B) and flip switch towards driver's side window (driver's left panel).
- 2. Turn 24V battery switch to OFF position (C) by turning a quarter turn counterclockwise (located in the outside compartment at the front of the bus on the left hand side, directly below drivers window).



24V Battery Switch

ALTERNATE PROCEDURE #2 (if other two procedures are not possible)

- 1. Press in the red "ESD" button (D) on the fuel cell (engine compartment, at the back of the bus).
- 2. Turn 24V battery switch to OFF position (C) by turning a quarter turn counterclockwise (located in the outside compartment at the front of the bus on the left hand side, directly below drivers window).



ESD Button Location

WARNINGS

- NEVER cut, breach, or touch high voltage components or cabling. Doing so could result in serious injury or death.
- DO NOT cut the fuel lines, cutting fuel lines will result in an uncontrolled release of hydrogen gas.
- Fuel cell vehicles operate silently, lack of an engine noise does not mean the vehicle is OFF. Silent movement capability exists until vehicle is fully shut down.

VAN HOOL

VAN HOOL

A300L



H
See page 24.

(continued) EXTRICATION INFORMATION

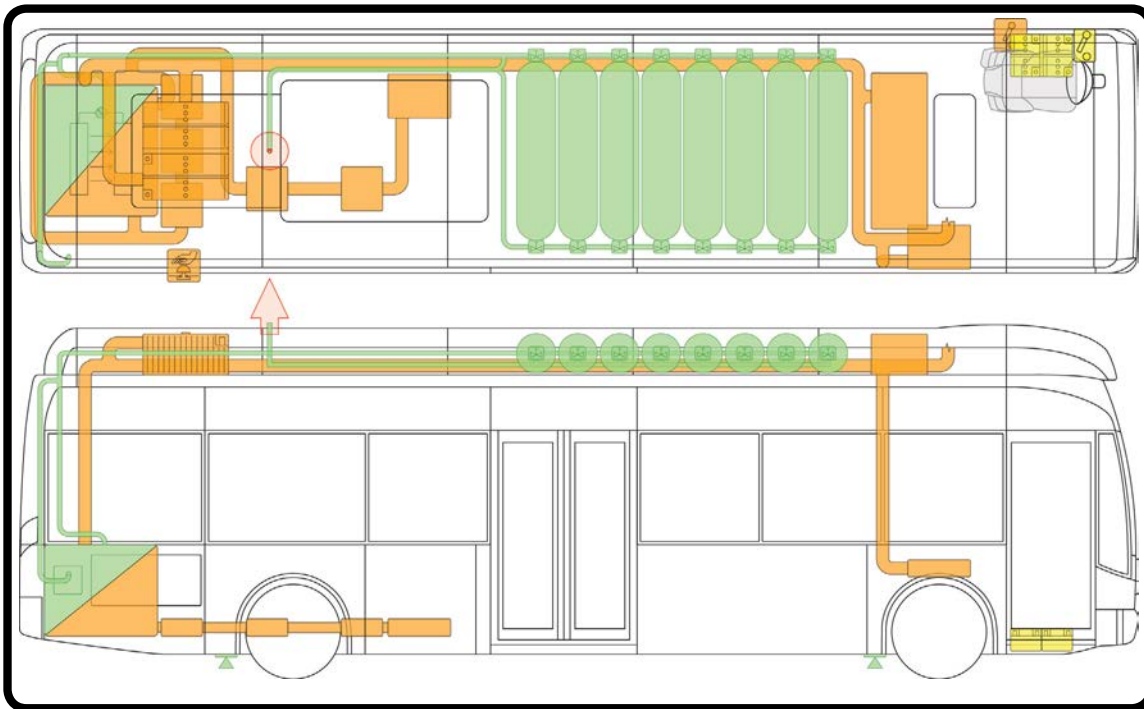

LEGEND			
	12V Battery		Fuel Tank
	High-Voltage Battery		Emergency Disconnect (Switch Off)
			High-Voltage Power Cable
			Pressure Relief Valve

For towing and post-incident instructions, see the **POST-INCIDENT** section on page 20.



2014-18

e-GOLF



VEHICLE INFORMATION

Li-ion

See pages 15, 22.

IMMOBILIZE VEHICLE

1. **Chock the wheels.**
2. **Set parking brake.**
(hand brake, center console)
3. **Place vehicle into park.**
(center console)

DISABLE VEHICLE

Determine if vehicle is ON. Vehicle is OFF if tachometer needle points to OFF.

PRIMARY PROCEDURE

1. If ON, turn the key to the OFF position (steering column), and remove key or press Start/Stop button (center console).
2. Access the fuse panel (left side of the instrument panel), open the cover and pull the fuse marked with a yellow flag.
3. Locate and disconnect the 12V battery (engine compartment).



Fuse Box Location

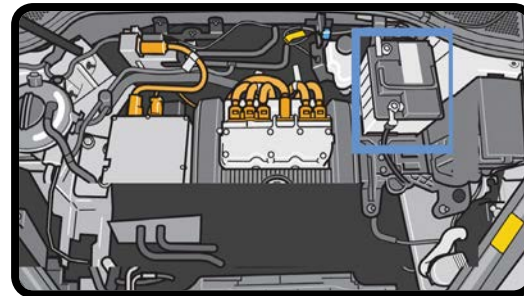

12V Battery Location

ALTERNATE PROCEDURE



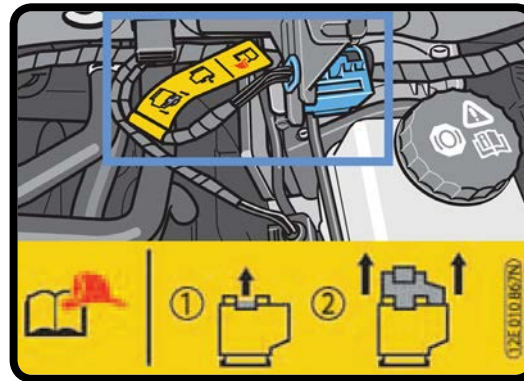

(if the ignition is not accessible)

1. Locate and disconnect the 12V battery (engine compartment).
2. Locate and disconnect the HV disconnecting point (engine compartment at the yellow marking) by pulling the connector apart as described on the marking.



12V Positive Cable

WARNINGS

-  NEVER cut, breach, or touch high voltage components or cabling. Doing so could result in serious injury or death.
-  High voltage cables and components may remain energized for up to 20 seconds after disabling.
-  Airbags and SRS may remain powered for up to 4 seconds after shutoff/disabling. Avoid breaching SRS components.
-  This vehicle does not have an internal combustion engine. Lack of engine noise does not mean vehicle is OFF. Silent movement capability exists until vehicle is fully shut down.

Volkswagen

VOLKSWAGEN

e-GOLF



2014-18

e-GOLF



e-GOLF

Li-ion

(continued)

EXTRICATION INFORMATION

See pages 15, 22.

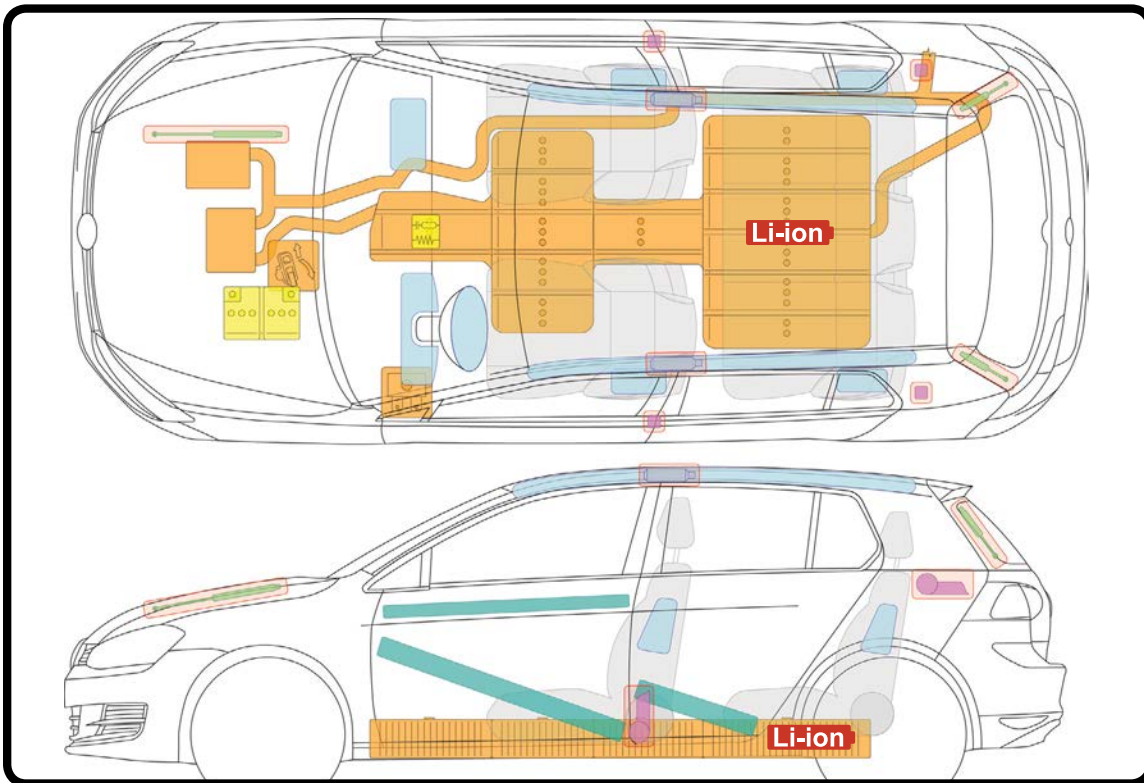

LEGEND

Airbag	Bodywork Reinforcements	SRS Control Unit
Stored Gas Inflator	Support Cylinder for Hood	12V Battery
Seatbelt Tensioner or Pretensioner		High-Voltage Power Cable
High-Voltage Battery	Emergency Disconnect (Remove Fuse)	Emergency Disconnect (Remove Plug)

A PLUGGED IN VEHICLE

1. Stop the charging process at the charger/charging station.
2. Always disconnect the charging connector.

For towing and post-incident instructions, see the **POST-INCIDENT** section on page 20.



Charging Connector

VOLKSWAGEN

Volkswagen



2011-16



HYBRID

VEHICLE INFORMATION

Li-ion

See pages 15, 22.

IMMOBILIZE VEHICLE

1. **Chock the wheels.**
2. **Set parking brake.**
(hand brake, center console)
3. **Place vehicle into park.**
(center console)

DISABLE VEHICLE

Determine if vehicle is ON. Vehicle is OFF if tachometer needle points to OFF.

PRIMARY PROCEDURE

1. If ON, turn the key to the OFF position (steering column), and remove key.
2. Press the Start/Stop button (center console) to the 2nd level.
3. Disconnect both red positive cables of the 12V battery (trunk, driver side).

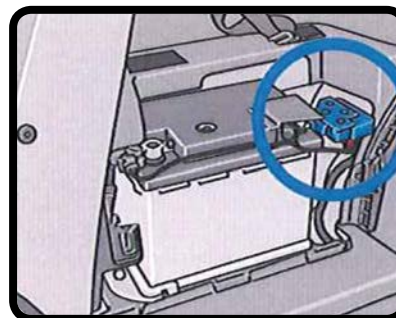

12V Battery

ALTERNATE PROCEDURE

(if the ignition and 12V battery are not accessible)

1. Open hood and remove the engine cover.
2. Locate the disconnecting point. The 12V connector (shown in yellow) is located at the height of the air filter between the radiator and engine.
3. Cut through the cable at the location marked with yellow tag.

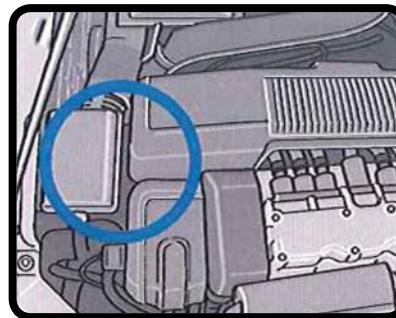

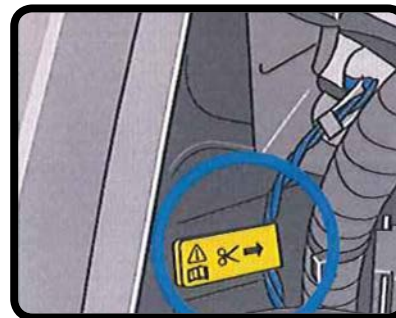

Engine Cover



Disconnect Point

WARNINGS

-  NEVER cut, breach, or touch high voltage components or cabling. Doing so could result in serious injury or death.
-  High voltage cables and components may remain energized for up to 20 seconds after disabling.
-  Lack of engine noise does not mean vehicle is OFF. Silent movement or instant restart capability exists until vehicle is fully shut down.

Volkswagen

VOLKSWAGEN

JETTA

HEV



2011-16

HYBRID



JETTA







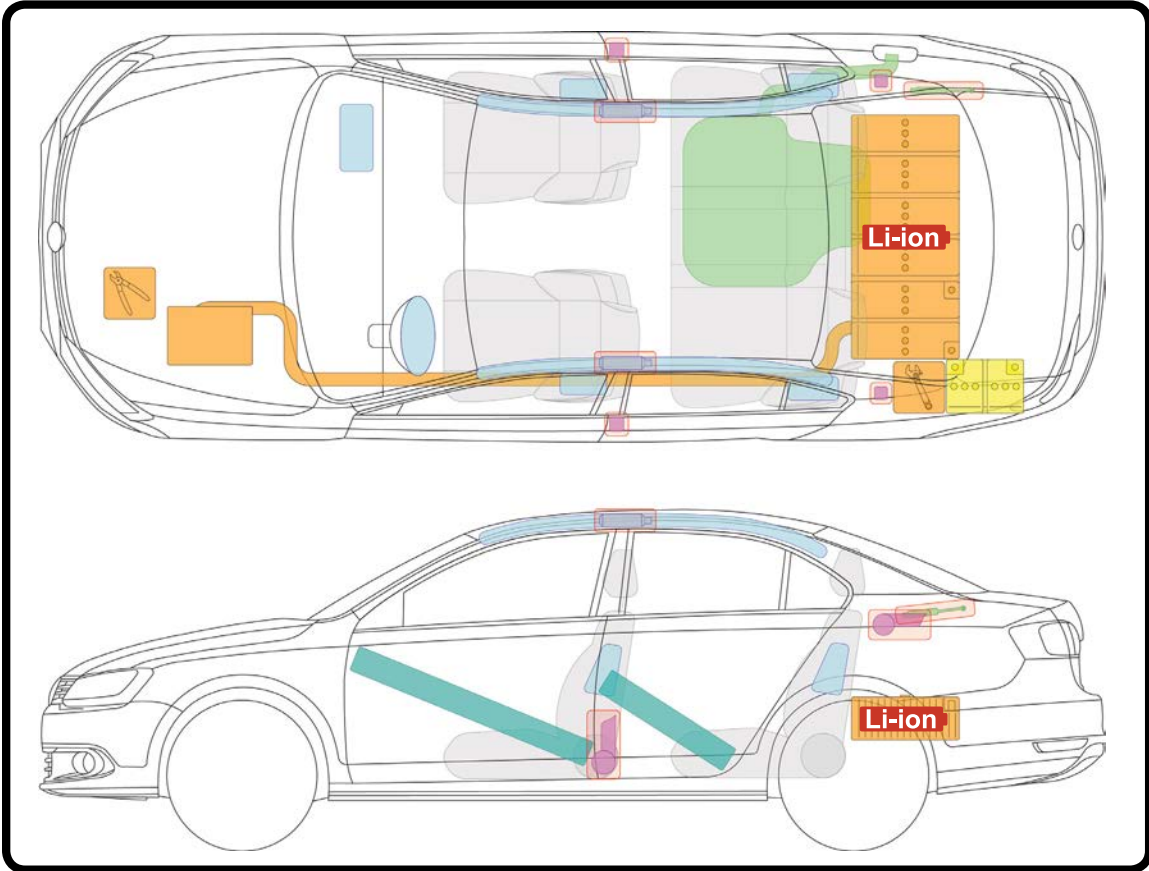

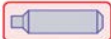

Li-ion (continued)

See pages 15, 22.

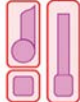
EXTRICATION INFORMATION



LEGEND

 Airbag	 Bodywork Reinforcements	 SRS Control Unit
 Stored Gas Inflator	 Support Cylinder for Hood	 12V Battery
 Seatbelt Tensioner or Pretensioner	 Fuel Tank	 High-Voltage Power Cable
 High-Voltage Battery	 Emergency Disconnect (Cut Cable)	 Emergency Disconnect (Unscrew Connector)

For towing and post-incident instructions, see the **POST-INCIDENT** section on page 20.

VOLKSWAGEN
Volkswagen



2011-14



HYBRID

Volkswagen

VOLKSWAGEN

TOUAREG

VEHICLE INFORMATION

IMMOBILIZE VEHICLE

1. **Chock the wheels.**
2. **Set parking brake.** (push/pull switch, center console)
3. **Place vehicle into park.** (center console)

DISABLE VEHICLE

Determine if vehicle is ON by illumination of digital displays.

PRIMARY PROCEDURE

1. If ON,
 - Conventional key: shut off ignition (instrument console), and remove key.
 - Proximity key: shut off ignition (push-button, center console) and remove key from vehicle.
2. Disconnect the 12V battery ground cable (access flap on the floor in front of driver's seat).

ALTERNATE PROCEDURE

(if the ignition and 12V battery are not accessible)

1. Lift the cargo floor in the luggage compartment.
2. Locate the disconnecting point. The 12V connector (shown in blue) is located on the E-box, on the left side of the high voltage battery next to the high voltage cable.
3. Disconnect the connector.

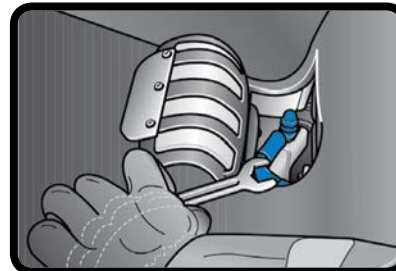

Disconnect the Ground at the Threaded Connection

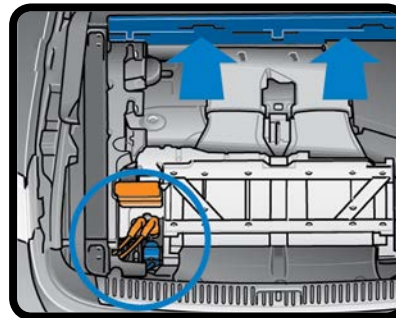

E-Box in Trunk



12V E-Box Disconnect

WARNINGS

- NEVER cut, breach, or touch high voltage components or cabling. Doing so could result in serious injury or death.
- High voltage cables and components may remain energized for up to 20 seconds after disabling.
- Failure to disconnect 12V battery could result in airbag deployment, even if 12V connector on E-box is disconnected.
- Lack of engine noise does not mean vehicle is OFF. Silent movement or instant restart capability exists until vehicle is fully shut down.

HEV



2011-14

HYBRID







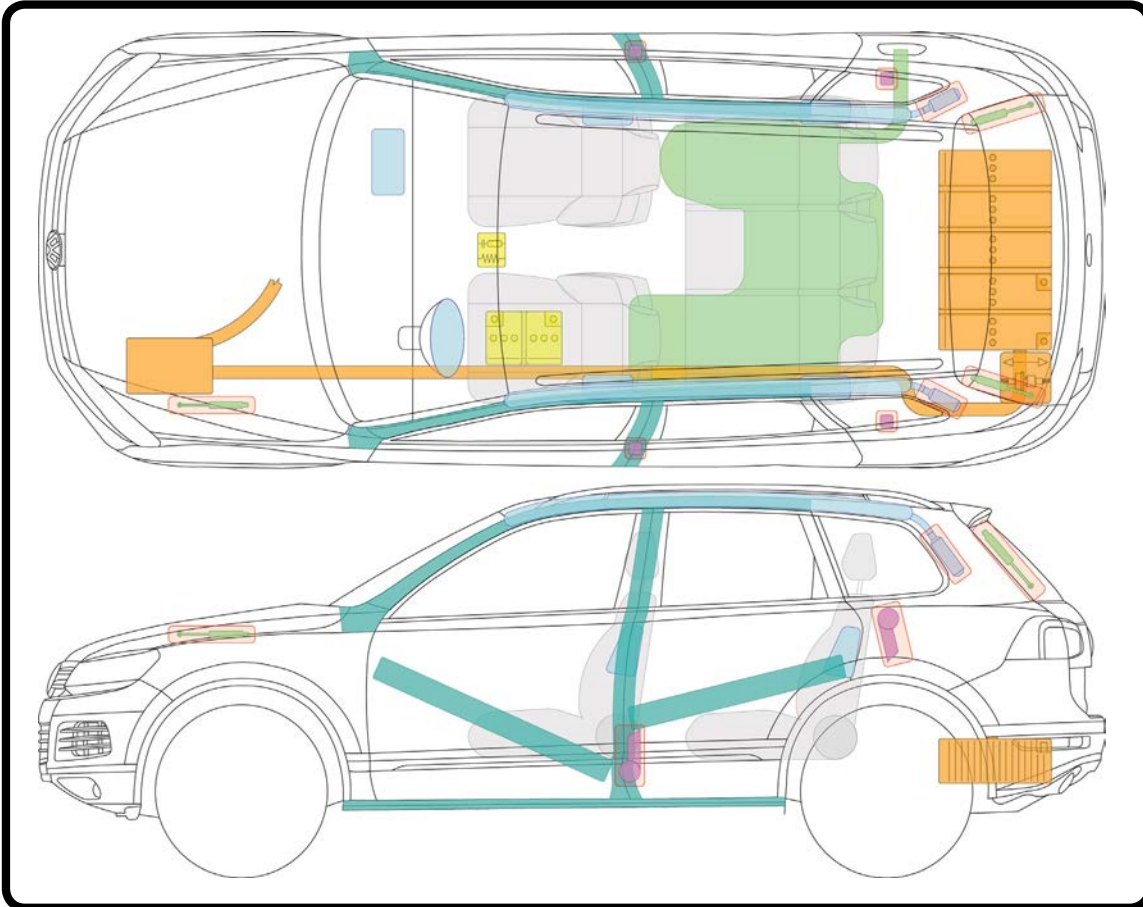





Touareg

(continued) EXTRICATION INFORMATION

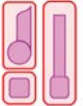

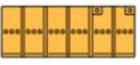
LEGEND

 Airbag	 Bodywork Reinforcements	 SRS Control Unit
 Stored Gas Inflator	 Support Cylinder for Hood	 12V Battery
 Seatbelt Tensioner or Pretensioner	 Fuel Tank	 High-Voltage Power Cable
 High-Voltage Battery	 Emergency Disconnect (Disconnect Plug)	

For towing and post-incident instructions, see the **POST-INCIDENT** section on page 20.

VOLKSWAGEN

Volkswagen



2011-12



VEHICLE INFORMATION

Li-ion

See pages 15, 22.

IMMOBILIZE VEHICLE

- 1. **Chock the wheels.**
- 2. **Set parking brake.**
(hand brake, center console)
- 3. **Place vehicle in neutral.**
(center console)

DISABLE VEHICLE

Determine if vehicle is ON by illumination of READY light.

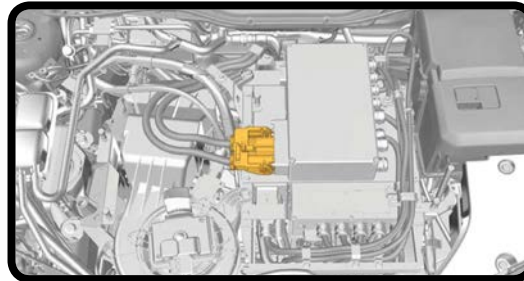

PRIMARY PROCEDURE

- 1. If ON, turn the key to the OFF position and remove key.
- 2. Disconnect 12V battery negative cable (engine compartment, driver's side).
- 3. Use service/emergency disconnect switch (engine compartment).



Service/Emergency Disconnect Switch

WARNINGS

-  NEVER cut, breach, or touch high voltage components or cabling. Doing so could result in serious injury or death.
-  Airbags and SRS may remain powered for up to 15 seconds after shutoff/disabling. Avoid breaching SRS components.
-  This vehicle does not have an internal combustion engine. Lack of engine noise does not mean vehicle is OFF. Silent movement capability exists until vehicle is fully shut down.

VOLVO

C30

VOLVO



2011-12









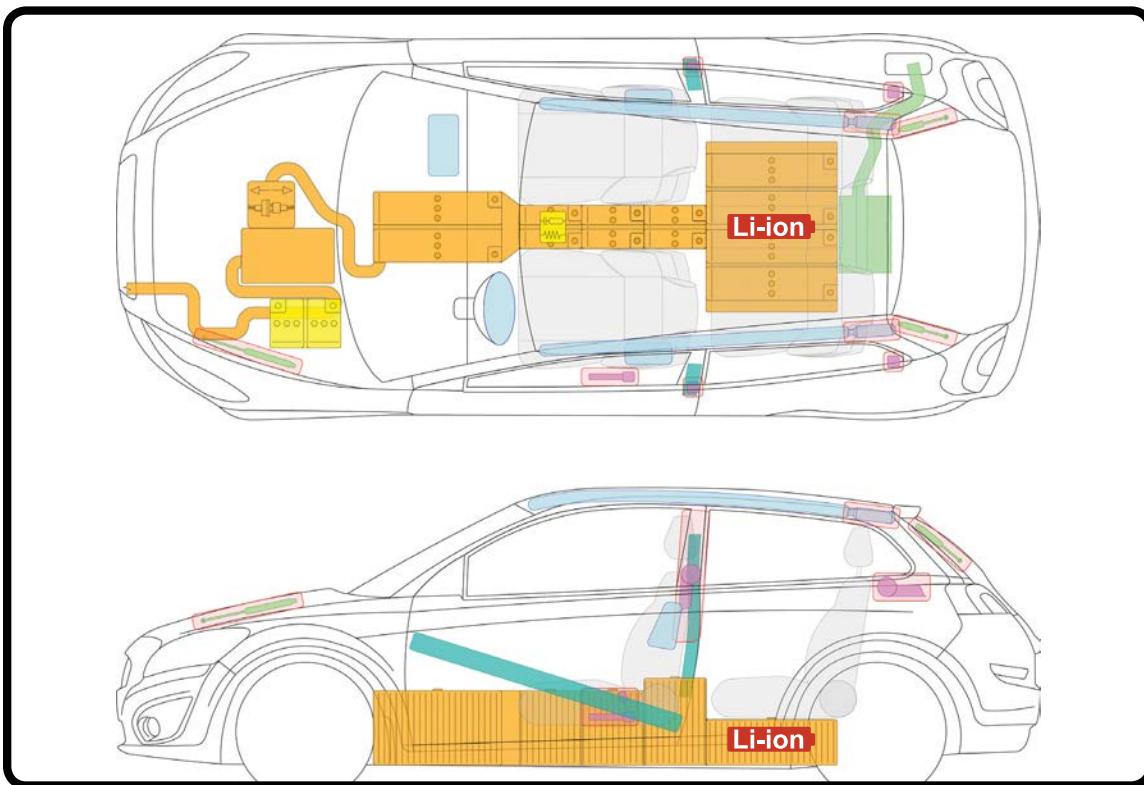

C30

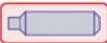
Li-ion (continued) **EXTRICATION INFORMATION**

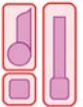
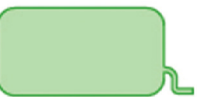
See pages 15, 22.



LEGEND		
 Airbag	 Bodywork Reinforcements	 SRS Control Unit
 Stored Gas Inflator	 Support Cylinder for Hood	 12V Battery
 Seatbelt Tensioner or Pretensioner	 Fuel Tank	 High-Voltage Power Cable
 High-Voltage Battery	 Emergency Disconnect (Disconnect Plug)	

A PLUGGED IN VEHICLE

1. Stop the charging process at the charger/charging station.
2. Always disconnect the charging connector.

For towing and post-incident instructions, see the **POST-INCIDENT** section on page 20.



Charging Connector

VOLVO



2016-18



VEHICLE INFORMATION

Li-ion

See pages 15, 22.

IMMOBILIZE VEHICLE

1. **Chock the wheels.**
2. **Set parking brake.**
(push/pull switch, left of steering wheel)
3. **Place vehicle into park.**
(center console)

DISABLE VEHICLE

Determine if vehicle is ON by illumination of VEHICLE IS RUNNING indicator on center gauge.

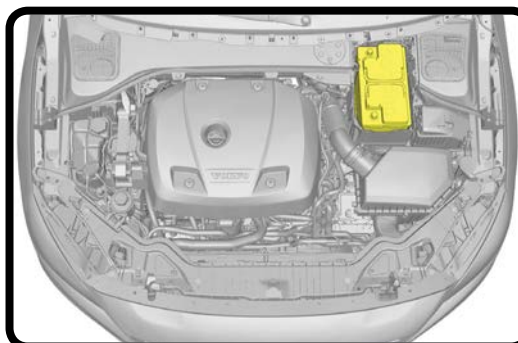

PRIMARY PROCEDURE

1. If ON, shut off ignition (START/STOP button, right of instrument panel).
2. Remove proximity key and keep it at least 16 feet (5 meters) from vehicle.
3. Disconnect 12V battery negative cable (engine compartment, driver's side).



12V Battery Driver's Side

WARNINGS

-  NEVER cut, breach, or touch high voltage components or cabling. Doing so could result in serious injury or death.
-  Airbags and SRS may remain powered for up to 30 seconds after shutoff/disabling. Avoid breaching SRS components.
-  Lack of engine noise does not mean vehicle is OFF. Silent movement capability exists until vehicle is fully shut down.

VOLVO

S60

VOLVO



2016-18









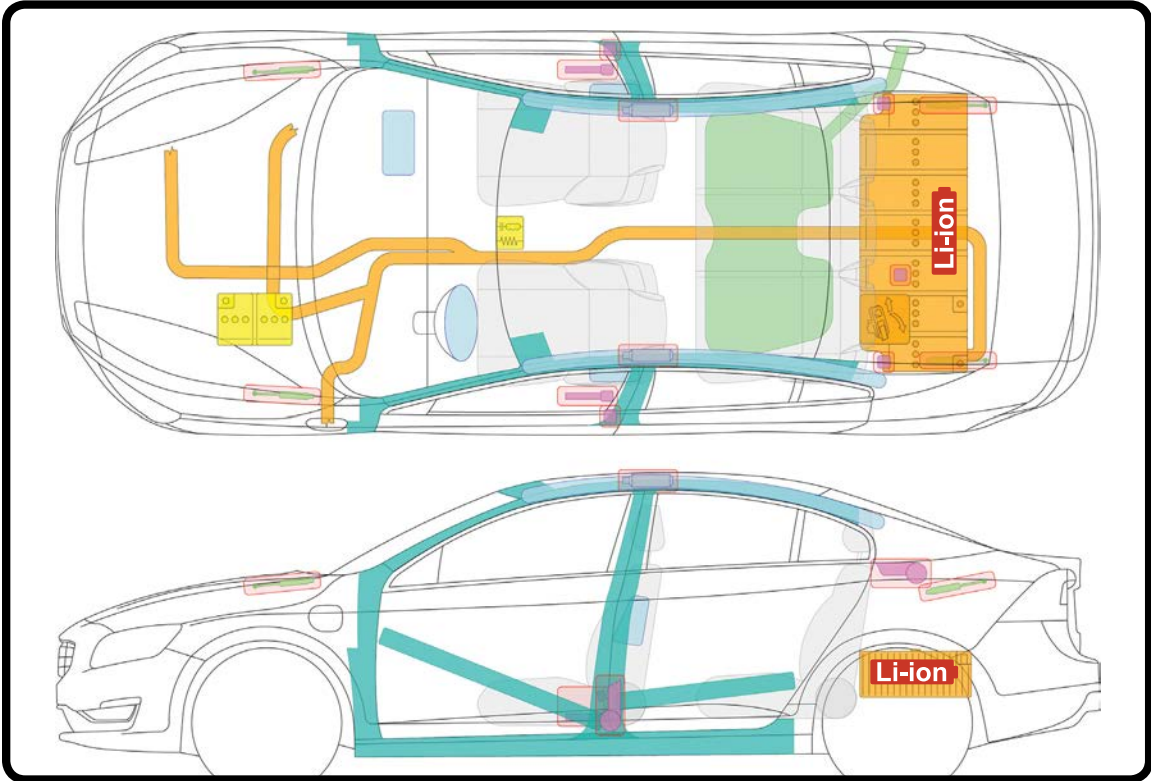

S60

Li-ion (continued) **EXTRICATION INFORMATION**

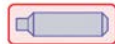
See pages 15, 22.

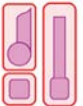

LEGEND

 Airbag	 Bodywork Reinforcements	 SRS Control Unit
 Stored Gas Inflator	 Support Cylinder for Hood	 12V Battery
 Seatbelt Tensioner or Pretensioner	 Fuel Tank	 High-Voltage Power Cable
 High-Voltage Battery		 Emergency Disconnect (Remove Plug)

A PLUGGED IN VEHICLE

1. Stop the charging process at the charger/charging station.
2. Always disconnect the charging connector.

For towing and post-incident instructions, see the **POST-INCIDENT** section on page 20.



Charging Connector



2017-18



VEHICLE INFORMATION

Li-ion

See pages 15, 22.

IMMOBILIZE VEHICLE

1. **Chock the wheels.**
2. **Set parking brake.**
(push/pull switch, center console)
3. **Place vehicle into park.**
(center console)

DISABLE VEHICLE

Determine if vehicle is ON. Vehicle is ON if the right hand gauge needle points to READY.

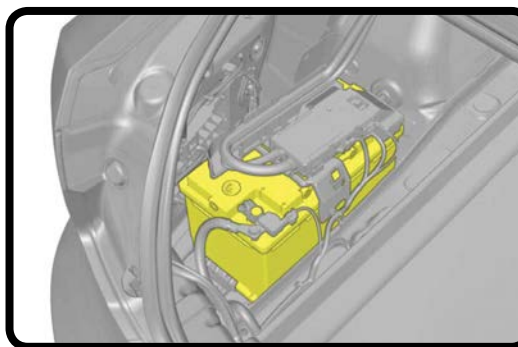

PRIMARY PROCEDURE

1. If ON, Turn the START/STOP (center console) button to STOP.
2. Remove proximity key and keep it at least 16 feet (5 meters) from vehicle.
3. Disconnect 12V battery negative cable (trunk, driver's side).



12V Battery in Trunk, Driver's Side

WARNINGS

-  NEVER cut, breach, or touch high voltage components or cabling. Doing so could result in serious injury or death.
-  Airbags and SRS may remain powered for up to 30 seconds after shutoff/disabling. Avoid breaching SRS components.
-  Lack of engine noise does not mean vehicle is OFF. Silent movement capability exists until vehicle is fully shut down.

VOLVO

S90

VOLVO



2017-18









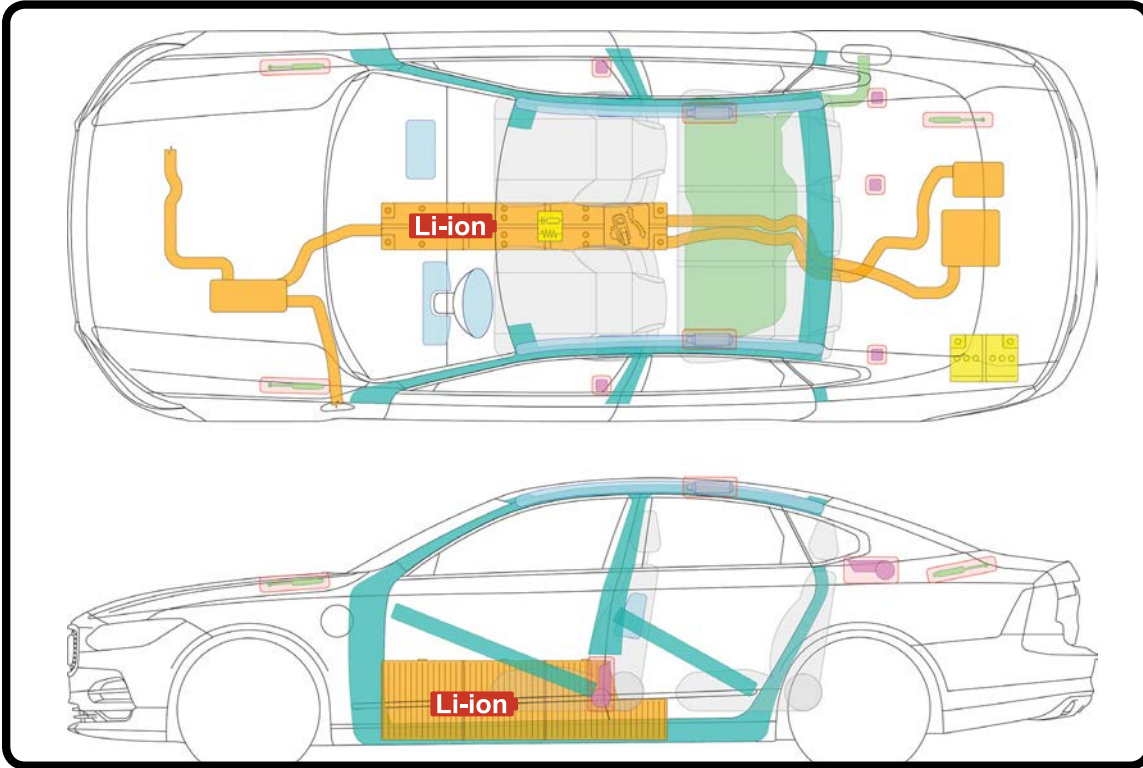

S90

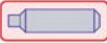
Li-ion (continued) **EXTRICATION INFORMATION**

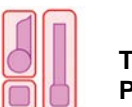
See pages 15, 22.



LEGEND		
 Airbag	 Bodywork Reinforcements	 SRS Control Unit
 Stored Gas Inflator	 Support Cylinder for Hood	 12V Battery
 Seatbelt Tensioner or Pretensioner	 Fuel Tank	 High-Voltage Power Cable
 High-Voltage Battery		 Emergency Disconnect (Remove Plug)

A PLUGGED IN VEHICLE

1. Stop the charging process at the charger/charging station.
2. Always disconnect the charging connector.

For towing and post-incident instructions, see the **POST-INCIDENT** section on page 20.



Charging Connector



2017-18

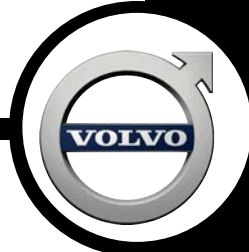

VEHICLE INFORMATION

Li-ion

See pages 15, 22.

IMMOBILIZE VEHICLE

1. **Chock the wheels.**
2. **Set parking brake.**
(push/pull switch, center console)
3. **Place vehicle into park.**
(center console)

DISABLE VEHICLE

Determine if vehicle is ON. Vehicle is ON if the right hand gauge needle points to READY.

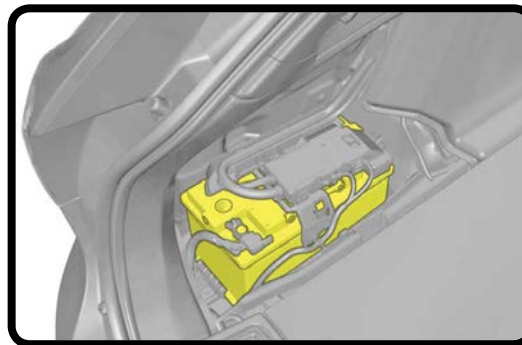

PRIMARY PROCEDURE

1. If ON, Turn the START/STOP button (center console) to STOP.
2. Remove proximity key and keep it at least 16 feet (5 meters) from vehicle.
3. Disconnect 12V battery negative cable (trunk, driver's side).



12V Battery in Trunk, Driver's Side

WARNINGS

-  NEVER cut, breach, or touch high voltage components or cabling. Doing so could result in serious injury or death.
-  Airbags and SRS may remain powered for up to 30 seconds after shutoff/disabling. Avoid breaching SRS components.
-  Lack of engine noise does not mean vehicle is OFF. Silent movement capability exists until vehicle is fully shut down.

VOLVO

VOLVO



2017-18









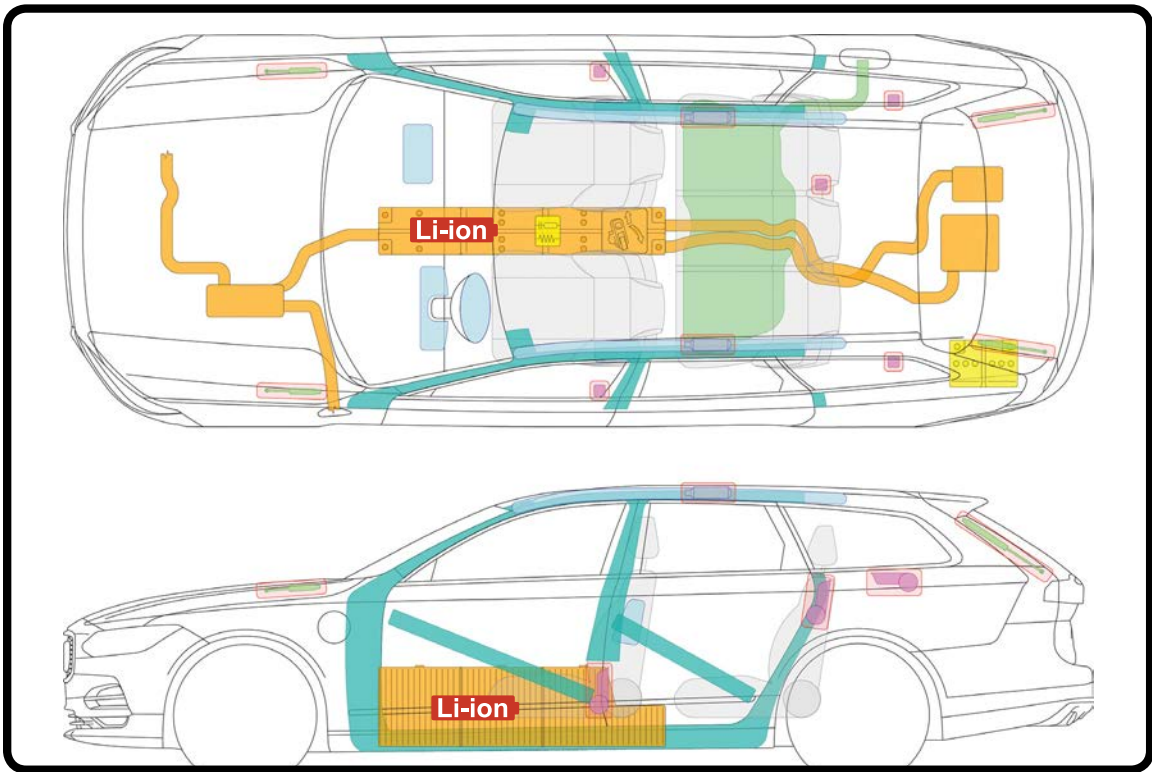

V90

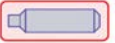
Li-ion (continued) **EXTRICATION INFORMATION**

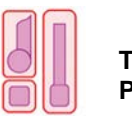
See pages 15, 22.



LEGEND		
 Airbag	 Bodywork Reinforcements	 SRS Control Unit
 Stored Gas Inflator	 Support Cylinder for Hood	 12V Battery
 Seatbelt Tensioner or Pretensioner	 Fuel Tank	 High-Voltage Power Cable
 High-Voltage Battery		 Emergency Disconnect (Remove Plug)

A PLUGGED IN VEHICLE

1. Stop the charging process at the charger/charging station.
2. Always disconnect the charging connector.

For towing and post-incident instructions, see the **POST-INCIDENT** section on page 20.



Charging Connector

VOLVO



2018

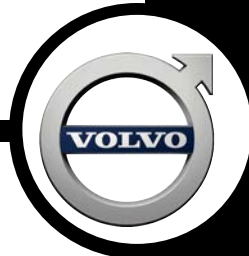

VEHICLE INFORMATION

Li-ion

See pages 15, 22.

IMMOBILIZE VEHICLE

- 1. **Chock the wheels.**
- 2. **Set parking brake.**
(push/pull switch, center console)
- 3. **Place vehicle into park.**
(center console)

DISABLE VEHICLE

Determine if vehicle is ON. Vehicle is ON if the right hand gauge needle points to READY.



PRIMARY PROCEDURE

- 1. If ON, Turn the START/STOP button (center console) to STOP.
- 2. Remove proximity key and keep it at least 16 feet (5 meters) from vehicle.
- 3. Disconnect 12V battery negative cable (trunk).



12V Battery in Trunk

WARNINGS

-  NEVER cut, breach, or touch high voltage components or cabling. Doing so could result in serious injury or death.
-  Airbags and SRS may remain powered for up to 30 seconds after shutoff/disabling. Avoid breaching SRS components.
-  Lack of engine noise does not mean vehicle is OFF. Silent movement capability exists until vehicle is fully shut down.

VOLVO

XC60

VOLVO



2018









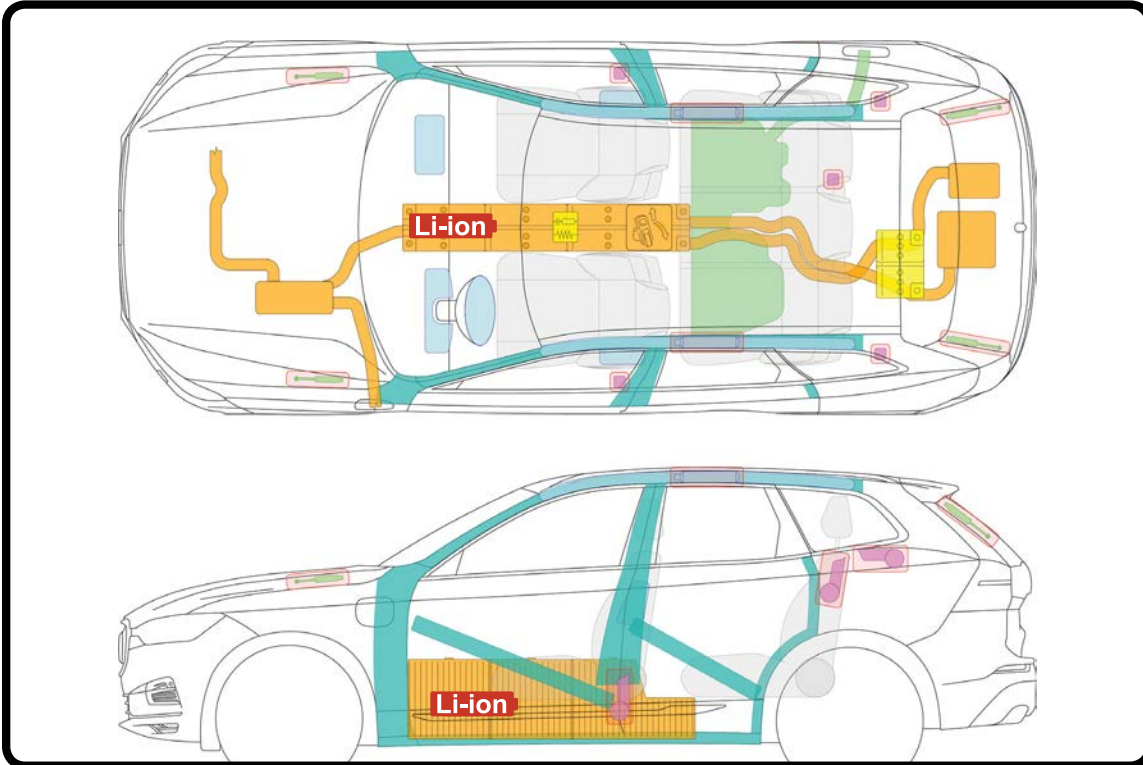

XC60

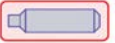
Li-ion (continued) **EXTRICATION INFORMATION**

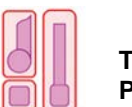
See pages 15, 22.



LEGEND		
 Airbag	 Bodywork Reinforcements	 SRS Control Unit
 Stored Gas Inflator	 Support Cylinder for Hood	 12V Battery
 Seatbelt Tensioner or Pretensioner	 Fuel Tank	 High-Voltage Power Cable
 High-Voltage Battery		 Emergency Disconnect (Remove Plug)

A PLUGGED IN VEHICLE

1. Stop the charging process at the charger/charging station.
2. Always disconnect the charging connector.

For towing and post-incident instructions, see the **POST-INCIDENT** section on page 20.



Charging Connector



2016-18



VEHICLE INFORMATION

Li-ion

See pages 15, 22.

IMMOBILIZE VEHICLE

- 1. **Chock the wheels.**
- 2. **Set parking brake.**
(push/pull switch, center console)
- 3. **Place vehicle into park.**
(center console)

DISABLE VEHICLE

Determine if vehicle is ON. Vehicle is ON if tachometer needle points to READY.

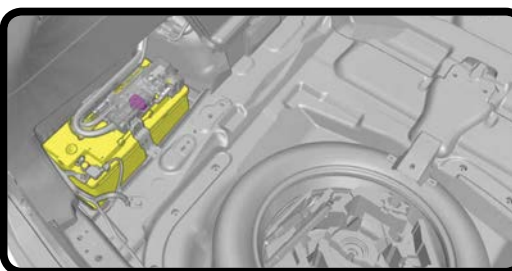

PRIMARY PROCEDURE

- 1. If ON, Turn the START/STOP button (center console) to STOP.
- 2. Remove proximity key and keep it at least 16 feet (5 meters) from vehicle.
- 3. Disconnect 12V battery negative cable (trunk, driver's side).



12V Battery in Trunk, Driver's Side

WARNINGS

-  NEVER cut, breach, or touch high voltage components or cabling. Doing so could result in serious injury or death.
-  Airbags and SRS may remain powered for up to 30 seconds after shutoff/disabling. Avoid breaching SRS components.
-  Lack of engine noise does not mean vehicle is OFF. Silent movement capability exists until vehicle is fully shut down.

VOLVO

XC90

VOLVO



2016-18









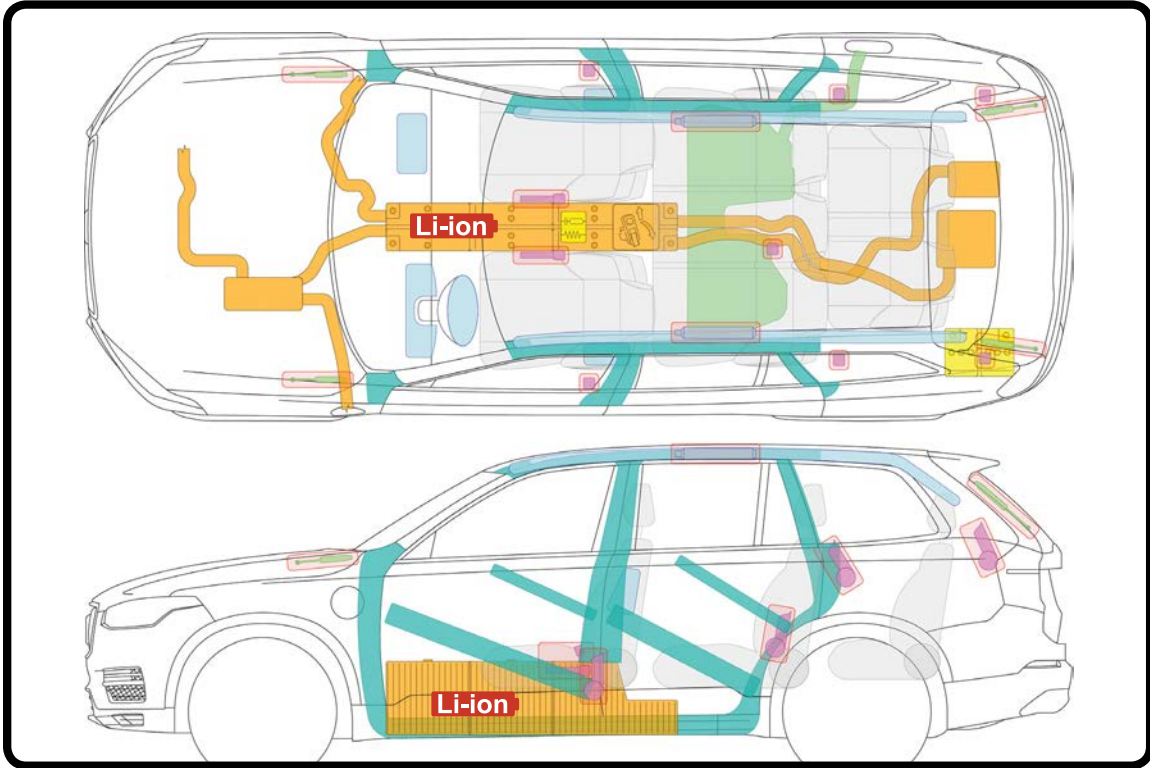

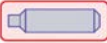

XC90

Li-ion (continued) **EXTRICATION INFORMATION**

See pages 15, 22.



LEGEND

 Airbag	 Bodywork Reinforcements	 SRS Control Unit
 Stored Gas Inflator	 Support Cylinder for Hood	 12V Battery
 Seatbelt Tensioner or Pretensioner	 Fuel Tank	 High-Voltage Power Cable
 High-Voltage Battery		 Emergency Disconnect (Remove Plug)

A PLUGGED IN VEHICLE

1. Stop the charging process at the charger/charging station.
2. Always disconnect the charging connector.

For towing and post-incident instructions, see the **POST-INCIDENT** section on page 20.



Charging Connector

VOLVO



2010-15

XLhybrids

XL HYBRIDS

XLhybrids

Van Conversion

VEHICLE INFORMATION

NOTE: This is an aftermarket system installed onto an existing chassis. Typically installed on a GMC Savana or a Chevy Express - 2500 or 3500 models.

IDENTIFICATION: Decals on the driver side B pillar can identify a vehicle equipped with the XLH HEV system. Decals are only visible when the door is open.



Driver Side B Pillar

IMMOBILIZE VEHICLE

- 1. **Chock the wheels.**
- 2. **Set parking brake.** (foot pedal)
- 3. **Place vehicle into park.** (gear selector, steering column)

DISABLE VEHICLE

PRIMARY PROCEDURE

- 1. Turn ignition key to the OFF position and remove key (steering column).
- 2. Disconnect the 12V battery (engine compartment).

ALTERNATE PROCEDURE



(if ignition key is inaccessible)

- 1. Disconnect the 12V battery (engine compartment).
- 2. Unplug the HV disconnect plug (under driver's seat towards rear of base).



HV Disconnect Under Driver's Seat

WARNINGS

-  NEVER cut, breach, or touch high voltage components or cabling. Doing so could result in serious injury or death.
-  The high voltage system may remain powered for up to 5 minutes after shutoff/disabling. Avoid touching, cutting, or opening any orange high voltage cable or component.
-  Lack of engine noise does not mean vehicle is OFF. Silent movement or instant restart capability exists until vehicle is fully shut down.

XLhybrids

2010-15



(continued) EXTRICATION INFORMATION

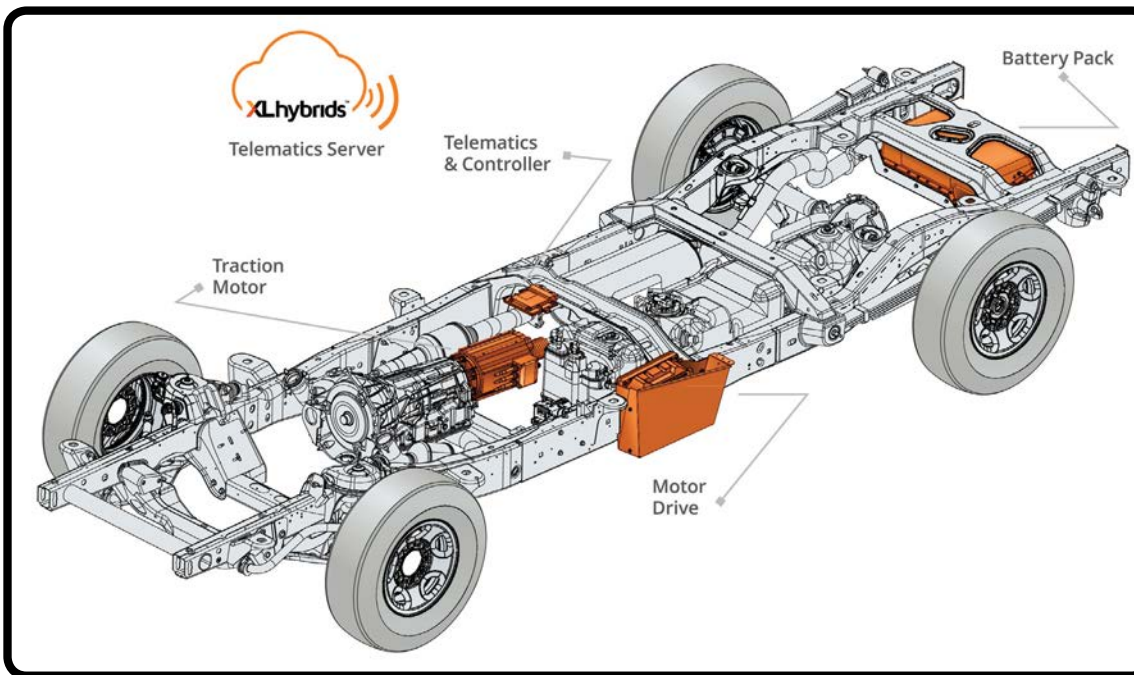

For towing and post-incident instructions, see the **POST-INCIDENT** section on page 20.



EFG ACKNOWLEDGMENTS

All vehicle-specific images, graphics, logos, and trademarks used with permission. All rights reserved. All material herein is copyrighted either by NFPA or the vehicle manufacturer. Neither the NFPA original content, nor the content provided by the participating manufacturers, may be reproduced or excerpted for any purpose, even where not specifically stated in the acknowledgments.

The National Fire Protection Association would like to thank all of the following auto manufacturers for their participation in this project, as well as their dedication to the safety of first and second responders.

American Honda Motor Co.

BMW of North America, LLC

Chrysler Group, LLC (includes Dodge)

Electric Vehicles International

Fisker Automotive, Inc.

Ford Motor Company (includes Lincoln and Mercury)

Copyright 2012, Ford Motor Company. All rights reserved. Ford Motor Company content may be reproduced in its entirety and distributed for emergency responder use only. It may not be excerpted for any purpose.

General Motors Company (includes Buick, Cadillac, Chevrolet, GMC, and Saturn)

Gillig Corporation

Hyundai Motor America

Kia Motors America, Inc.

Mazda North American Operations

Copyright 2012, Mazda Motor of America, Inc. All Mazda trademarks are used solely by permission of Mazda Motor of America, Inc.



ACKNOWLEDGMENTS

Mercedes-Benz USA, LLC (includes Smart)

Mitsubishi Motors North America, Inc.

All rights reserved. Mitsubishi Motors North America content may not be altered or used without the written permission of Mitsubishi Motors North America.

Nissan North America (includes Infiniti)

Nissan model names and the Nissan logo are registered trademarks. © 2011

Porsche Cars North America, Inc.

Proterra, Inc.

Tesla Motors, Inc.

Toyota Motor Sales, U.S.A., Inc. (includes Lexus and Scion)

Portions of materials contained herein have been reprinted under license from Toyota Motor Sales, U.S.A., Inc., License Agreement TMS1009. All information contained herein about Toyota, Lexus, and Scion vehicles is based on the latest product information available at the time of publication, is provided “as is” without warranty of any kind, and is intended for service providers and other interested parties in Canada, Mexico, and the United States of America, including Guam, Puerto Rico, and the U.S. Virgin Islands. Specifications and procedures are subject to change without notice.

Volkswagen Group of America

All Volkswagen trademarks and materials are used with permission of Volkswagen Group of America, Inc.

XL Hybrids, Inc.

A special thanks to **Moditech Rescue Solutions B.V.** for providing the standardized extrication diagrams from their **Crash Recovery System.**

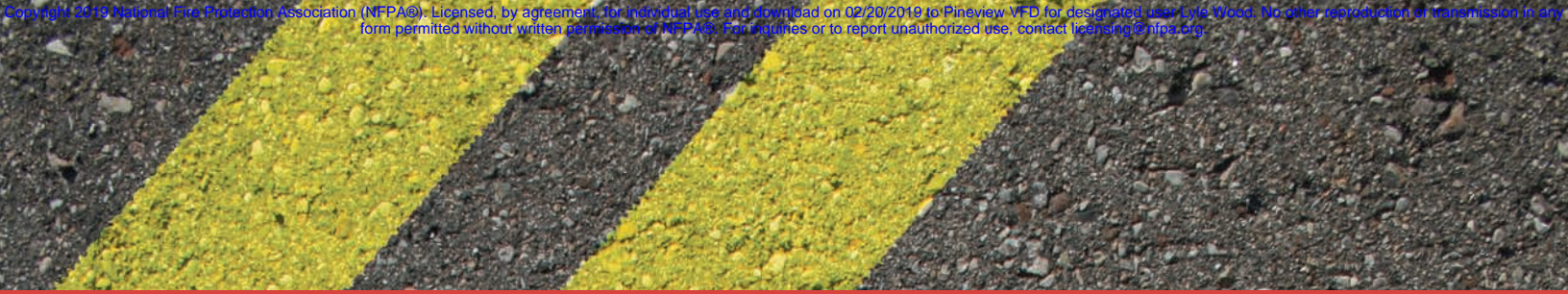

ISBN 978-1-4559-1274-2



9 781455 912742



9 0 0 0 0 >

This block contains the book's ISBN information. At the top, the text "ISBN 978-1-4559-1274-2" is printed. Below this is a standard 1D barcode. Underneath the barcode, the numbers "9 781455 912742" are printed. To the right of the main barcode is a smaller barcode with the numbers "9 0 0 0 0 >" printed above it.